



 & Peta Proses Bisnis  
Standar Operasional  
Prosedur  
Universitas Trunojoyo Madura  
Tahun 2019



KEMENTERIAN RISET, TEKNOLOGI, DAN PENDIDIKAN TINGGI

**UNIVERSITAS TRUNOJOYO MADURA**

Jl. Raya Telang, PO BOX 2 Kamal, Bangkalan-Madura

Telp. (031) 3011146, Fax. (031) 3011506

Laman : [www.trunojoyo.ac.id](http://www.trunojoyo.ac.id)

---

KEPUTUSAN REKTOR UNIVERSITAS TRUNOJOYO MADURA  
NOMOR 164/UN46/2019

TENTANG

PETA PROSES BISNIS DAN STANDAR OPERASIONAL PROSEDUR  
UNIVERSITAS TRUNOJOYO MADURA

REKTOR UNIVERSITAS TRUNOJOYO MADURA,

- Menimbang : a. bahwa untuk melaksanakan ketentuan pasal 19 Peraturan Menteri Riset, Teknologi dan Pendidikan Tinggi Nomor 71 tahun 2017 tentang Pedoman Penyusunan dan Evaluasi Peta Proses Bisnis dan Standar Operasional Prosedur Di Lingkungan Kementerian Riset, Teknologi, dan Pendidikan Tinggi, perlu disusun peta proses bisnis dan standar operasional prosedur di Universitas Trunojoyo Madura
- b. bahwa berdasarkan pertimbangan sebagaimana dimaksud dalam huruf a, perlu menetapkan keputusan Rektor tentang Peta Proses Bisnis dan Standar Operasional Prosedur Universitas Trunojoyo Madura;
- Mengingat : 1. Undang-Undang Nomor 25 Tahun 2009 tentang Pelayanan Publik (Lembaran Negara Republik Indonesia Tahun 2009 Nomor 112, Tambahan Lembaran Negara Republik Indonesia Nomor 5038);
2. Peraturan Pemerintah Nomor 96 Tahun 2012 tentang Pelaksanaan Undang-Undang Republik Indonesia Nomor 25 Tahun 2009 Tentang Pelayanan Public (Lembaran Negara Republik Indonesia Tahun 2009 Nomor 112, Tambahan Lembaran Negara Republik Indonesia Nomor 5038)
3. Keputusan Presiden Nomor 85 Tahun 2001 tentang Pendirian Universitas Trunojoyo;
4. Peraturan Menteri Riset, Teknologi, dan Pendidikan Tinggi Nomor 35 Tahun 2015 Tentang Organisasi dan Tata Kerja Universitas Trunojoyo Madura (Berita Negara Republik Indonesia Tahun 2015 Nomor 1792)
5. Peraturan Menteri Riset, Teknologi, dan Pendidikan Tinggi Nomor 71 Tahun 2017 Tentang Pedoman Penyusunan dan Evaluasi Peta Proses Bisnis dan Standar Operasional Prosedur di Lingkungan Kementerian Riset, Teknologi, dan Pendidikan Tinggi (Berita Negara Republik Indonesia Tahun 2017 Nomor 1640)
6. Keputusan Menteri Riset, Teknologi dan Pendidikan Tinggi Nomor 831/M/KPT.KP/2018 tentang Pemberhentian dan Pengangkatan Rektor Universitas Trunojoyo Madura Periode tahun 2018 – 2022;

MEMUTUSKAN:

Menetapkan : KEPUTUSAN REKTOR UNIVERSITAS TRUNOJOYO MADURA TENTANG PETA PROSES BISNIS DAN STANDAR OPERASIONAL PROSEDUR UNIVERSITAS TRUNOJOYO MADURA.

KESATU : Peta Proses Bisnis dan Standar Operasional Prosedur Universitas Trunojoyo Madura sebagaimana tercantum dalam lampiran yang merupakan bagian tidak terpisahkan dari keputusan Rektor ini.

KEDUA : Peta proses bisnis dan standar operasional prosedur digunakan sebagai acuan bagi seluruh unit kerja di lingkungan Universitas Trunojoyo Madura dalam melaksanakan tugas dan fungsinya.

KETIGA : Keputusan Rektor Universitas Trunojoyo Madura ini mulai berlaku sejak tanggal ditetapkan.

Ditetapkan di Bangkalan  
pada tanggal 28 Maret 2019  
REKTOR UNIVERSITAS TRUNOJOYO  
MADURA,



Dr. Drs. Ec. H. MUH SYARIF, M.Si  
NIP. 196311302001121001



## Daftar Isi

<b>PETA PROSES BISNIS DAN STANDAR OPERASIONAL PROSEDUR.....</b>	<b>1</b>
1 L0 - PETA PROSES BISNIS UNIVERSITAS TRUNOJOYO MADURA .....	9
2 L1 - PENDIDIKAN .....	10
3 L2 - KOORDINASI KEGIATAN PENINGKATAN PENGEMBANGAN PEMBELAJARAN DAN PENJAMINAN MUTU PENDIDIKAN .....	11
4 L2 - PELAKSANAAN KEGIATAN PENINGKATAN PENGEMBANGAN PEMBELAJARAN .....	12
5 L2 - PELAKSANAAN KEGIATAN PENINGKATAN PENGEMBANGAN PENJAMINAN MUTU PENDIDIKAN.....	13
6 L2 - PEMANTAUAN DAN EVALUASI KEGIATAN PENINGKATAN PENGEMBANGAN PEMBELAJARAN .....	14
7 L1 - PENELITIAN .....	15
8 L2 - PELAKSANAAN PENELITIAN DASAR, TERAPAN, PENGEMBANGAN DAN PENUGASAN .....	16
9 L2 - PELAKSANAAN PENELITIAN KERJASAMA DENGAN INSTITUSI LAIN .....	17
10 L2 - PEMANTUAN DAN EVALUASI PENELITIAN.....	18
11 L2 - PELAPORAN DAN PUBLIKASI HASIL PENELITIAN .....	19
12 L1 - PENGABDIAN KEPADA MASYARAKAT.....	20
13 L2 - PELAKSANAAN PENGABDIAN KEPADA MASYARAKAT .....	21
14 L2 - PELAKSANAAN PENGABDIAN KEPADA MASYARAKAT KERJASAMA DENGAN INSTITUSI LAIN .....	22
15 L2 - PEMANTAUAN DAN EVALUASI PENGABDIAN KEPADA MASYARAKAT .....	24
16 L2 - PELAPORAN DAN PUBLIKASI HASIL PENGABDIAN KEPADA MASYARAKAT .....	25
17 L1 - LAYANAN AKADEMIK DAN KEMAHASISWAAN .....	26
18 L2 - LAYANAN AKADEMIK.....	27
19 L2 - LAYANAN KEMAHASISWAAN .....	28
20 L2 - LAYANAN PERENCANAAN.....	29
21 L2 - LAYANAN KERJASAMA .....	30
22 L1 - LAYANAN UMUM, HUKUM, TATA LAKSANA, BMN , KEPEGAWAIAN DAN KEUANGAN .....	31
23 L2 - LAYANAN TATA USAHA DAN KERUMAHTANGGAAN .....	32
24 L2 LAYANAN HUKUM DAN TATA LAKSANA.....	33
25 L2 LAYANAN BARANG MILIK NEGARA.....	34
26 L2 - LAYANAN KEPEGAWAIAN .....	35
27 L2 - LAYANAN KEUANGAN .....	36
28 L1 - LAYANAN PERPUSTAKAAN.....	37



## Peta Proses Bisnis dan Standar Operasional Prosedur

29	L2 - LAYANAN SIRKULASI .....	38
30	L1 - LAYANAN TEKNOLOGI INFORMASI DAN KOMUNIKASI.....	39
31	L2 - PENGEMBANGAN LAYANAN TIK.....	40
32	L2 - PENGELOLAAN DAN PEMBERIAN LAYANAN TIK.....	41
33	L1 - LAYANAN BAHASA.....	42
34	L1 - LAYANAN LABORATORIUM TERPADU .....	43
35	L1 - LAYANAN PENGAWASAN INTERNAL .....	44
36	SOP PERSETUJAN CUTI.....	45
37	SOP AKREDITASI.....	46
38	SOP AKTIF KEMBALI DARI CUTI KULIAH.....	47
39	SOP AKTIFASI BLOKIR KTA.....	48
40	SOP AUDIT INTERNAL.....	49
41	SOP AUDIT MUTU .....	50
42	SOP BANTUAN PELAYANAN PENDAFTARAN DAN REGISTRASI JALUR SNMPTN, SBMPTN, DAN MANDIRI .....	51
43	SOP BEBAS PUSTAKA.....	52
44	SOP BERHENTI STUDI SEMENTARA (BSS) .....	53
45	SOP CETAK SALINAN PEMBAYARAN UKT.....	54
46	SOP CORRECTIVE MAINTANANCE PERANGKAT .....	55
47	SOP DISEMINASI HASIL PENELITIAN.....	56
48	SOP ENGEMBANGAN INFRASTRUKTUR BACKBONE FIBER OPTIC.....	57
49	SOP EVALUASI DAN PENILAIAN PELAKSANAAN PROSES PEMBELAJARAN .....	58
50	SOP EVALUASI HASIL BELAJAR MENGAJAR .....	59
51	SOP FRONTLINE CUSTOMER SERVICE HELPDESK PTIK.....	60
52	SOP HER REGISTRASI MAHASISWA.....	61
53	SOP KARTU TAMU .....	62
54	SOP KENAIKAN GAJI BERKALA .....	63
55	SOP KENAIKAN PANGKAT .....	64
56	SOP KEPROTOKOLAN.....	65
57	SOP KOLEKSI DOKUMEN PENJAMINAN MUTU.....	66
58	SOP KULIAH TAMU.....	67
59	SOP KURSUS BAHASA.....	68
60	SOP LAYANAN CETAK KHS.....	69



## Peta Proses Bisnis dan Standar Operasional Prosedur

61	SOP LAYANAN DISPENSASI KEGIATAN.....	70
62	SOP LAYANAN E-TUGAS BELAJAR .....	71
63	SOP LAYANAN IJIN STUDI LANJUT.....	72
64	SOP LAYANAN IDENTIFIKASI DAN VERIFIKASI KERUSAKAN .....	73
65	SOP LAYANAN KENAIKAN JABATAN AKADEMIK DOSEN .....	74
66	SOP LAYANAN PELAKSANAAN UTSUAS .....	75
67	SOP LAYANAN PEMAKAIAN MOBIL DINAS.....	76
68	SOP LAYANAN PEMAKAIAN RUANGAN DI FAKULTAS.....	77
69	SOP LAYANAN PEMBAYARAN GAJI.....	78
70	SOP LAYANAN PEMBELIAN KONSUMSI RAPAT .....	79
71	SOP LAYANAN PEMBERLAKUAN KURIKULUM.....	80
72	SOP LAYANAN PEMBINAAN BAGI DOSEN YANG AKAN BERAKHIR MASA TUGAS BELAJAR .....	81
73	SOP LAYANAN PEMELIHARAAN DAN PERBAIKAN .....	82
74	SOP LAYANAN PEMINJAMAN ALAT.....	83
75	SOP LAYANAN PEMINJAMAN GEDUNG DAN RUANG UTM.....	84
76	SOP LAYANAN PENENTUAN DOSEN PEMBIMBIN TA.....	85
77	SOP LAYANAN PENERBITAN SURAT TUGAS.....	86
78	SOP LAYANAN PENETAPAN JADWAL DAN PANITIA UTSUAS.....	87
79	SOP LAYANAN PENGADAAN FAKULTAS .....	88
80	SOP LAYANAN PENGAJUAN MAGANG.....	89
81	SOP LAYANAN PENGAKTIFAN KEMBALI .....	90
82	SOP LAYANAN PENGEMBALIAN PEMINJAMAN ALAT .....	91
83	SOP LAYANAN PENGGUNAAN DANA UP.....	92
84	SOP LAYANAN PENGISIAN KPRS.....	93
85	SOP LAYANAN PENGISIAN KRS .....	94
86	SOP LAYANAN PENINJAUAN KURIKULUM.....	95
87	SOP LAYANAN PENYUSUNAN JADWAL UTS ATAU UAS .....	96
88	SOP LAYANAN PENYUSUNAN, PENETAPAN DAN SOSIALISASI VISI, MISI, TUJUAN DAN STRATEGI FAKULTAS.....	97
89	SOP LAYANAN PERENCANAAN TUGAS BELAJAR DOSEN.....	98
90	SOP LAYANAN PERPANJANGAN KARYAWAN KONTRAK .....	99
91	SOP LAYANAN REFERENSI.....	100
92	SOP LAYANAN RENCANA PELAKSANAAN PRAKTIKUM .....	101



## Peta Proses Bisnis dan Standar Operasional Prosedur

93	SOP LAYANAN REVIEW, ASISTENSI, KONSULTASI, SOSIALISASI .....	102
94	SOP LAYANAN SURAT TUGAS DOSEN PEMBIMBING MAGANG.....	103
95	SOP LAYANAN TERBITAN BERKALA(TUGAS AKHIRSKRIPSI).....	104
96	SOP LAYANAN TERIMA BUKU.....	105
97	SOP LAYANAN USULAN KP.....	106
98	SOP LAYANAN USULAN TUGAS BELAJAR FAKULTAS .....	107
99	SOP LAYANAN VALIDASI KETIDAKHADIRAN MAHASISWA .....	108
100	SOP LAYANAN VERIFIKASI DAN IDENTIFIKASI ANGGARAN PERBAIKAN.....	109
101	SOP MONEV ABDIMAS .....	110
102	SOP MONITORING DAN EVALUASI PENELITIAN KOMPETITIF NASIONAL, DESENTRALISASI DAN PENUGASAN.....	111
103	SOP OPERASIONAL MOBIL PINTAR.....	112
104	SOP PEGUSULAN PENSIUN.....	113
105	SOP PELAKSANAAN PENGGANTI IJAZAH.....	114
106	SOP PELAKSANAAN ABDIMAS SKEMA KOMPETITIF NASIONAL DESENTRALISASI DAN PENUGASAN.....	115
107	SOP PELAKSANAAN PENELITIAN DASAR, TERAPAN, PENGEMBANGAN, PENUGASAN .....	116
108	SOP PELAKSANAAN YUDISIUM.....	117
109	SOP PELANTIKAN .....	118
110	SOP PELAPORAN HASIL PEMBELAJARAN .....	119
111	SOP PEMANTAUAN DAN EVALUASI KEMAJUAN PELAKSANAAN ABDIMAS.....	120
112	SOP PEMBAHASAN RKAKL DIPA.....	121
113	SOP PEMBAHASAN TINJAUAN MANAJEMEN .....	122
114	SOP PEMBAYARAN GAJI PNS.....	123
115	SOP PEMBAYARAN KONTRAKTUAL .....	124
116	SOP PEMBAYARAN LS KONTRAKTUAL PNBPN .....	125
117	SOP PEMBAYARAN LS NON KONTRAKTUAL NON PNBPN.....	126
118	SOP PEMBAYARAN LS NON KONTRAKTUAL PNBPN .....	127
119	SOP PEMBAYARAN TUNJANGAN KEHORMATAN DAN SERTIFIKASI DOSEN NON PNBPN .....	128
120	SOP PEMBAYARAN UANG LEMBUR NON PNBPN .....	129
121	SOP PEMBAYARAN UANG MAKAN PNS.....	130
122	SOP PEMBAYARAN UKT TERLAMBAT .....	131
123	SOP PEMBERKASAN KEARSIPAN .....	132
124	SOP PEMBUATAN KARTU ANGGOTA .....	133



## Peta Proses Bisnis dan Standar Operasional Prosedur

125	SOP PEMERIKSAAN KHUSUS DAN TINDAK LANJUT.....	134
126	SOP PEMERIKSAAN RUTIN .....	135
127	SOP PEMUSNAHAN ARSIP .....	136
128	SOP PENDAFTARAN HASIL PENELITIAN ABDIMAS BERPOTENSI KI KE PUSAT HKI LPPM .....	137
129	SOP PENENTUAN JADWAL PERKULIAHAN.....	138
130	SOP PENENTUAN PENERIMAAN MAHASISWA MELALUI JALUR BIDIK MISI .....	139
131	SOP PENENTUAN PJMK.....	140
132	SOP PENERIMAAN MAHASISWA BARU JALUR SBMPTN.....	141
133	SOP PENERIMAAN MAHASISWA BARU JALUR SNMPTN.....	142
134	SOP PENERIMAAN MAHASISWA BARU JALUR MANDIRI.....	143
135	SOP PENERJEMAHAN .....	144
136	SOP PENETAPAN DAN PENANDATANGANAN MOU.....	145
137	SOP PENETAPAN DAN PENUGASAN ABDIMAS .....	146
138	SOP PENETAPAN PAGU MAHASISWA BARU .....	147
139	SOP PENGADUAN JARINGAN INTRANET DAN INTERNET .....	148
140	SOP PENGADUAN JARINGAN WIFI.....	149
141	SOP PENGAJUAN ANGGARAN PELAKSANAAN KEGIATAN KEMAHASISWAAN.....	150
142	SOP PENGAJUAN SPP LS.....	151
143	SOP PENGAJUAN TUGAS AKHIR.....	152
144	SOP PENGAKTIFAN KEMBALI DOSEN STUDI LANJUT .....	153
145	SOP PENGANGKATAN PNS.....	154
146	SOP PENGEMBANGAN PENGADAAN INFRASTRUKTUR PERANGKAT DEVICE IT .....	155
147	SOP PENGEMBANGAN INFRASTRUKTUR BACKBONE FIBER OPTIC.....	156
148	SOP PENGEMBANGAN INFRASTRUKTUR BACKBONE FIBER OPTIC PTP WIFI.....	157
149	SOP PENGEMBANGAN INFRASTRUKTUR WIFI AREA .....	158
150	SOP PENGEMBANGAN METODE PEMBELAJARAN .....	159
151	SOP PENGGANTI IJAZAH.....	160
152	SOP PENGISIAN KPRS.....	161
153	SOP PENGISIAN KRS .....	162
154	SOP PENGOLAHAN BAHAN PUSTAKA .....	163
155	SOP PENGUKUHAN GURU BESAR .....	164
156	SOP PENGUMPULAN LAPORAN AKHIR PENELITIAN ABDIMAS.....	165
157	SOP PENGUMPULAN PERUNDANG-UNDANGAN.....	166





## Peta Proses Bisnis dan Standar Operasional Prosedur

158	SOP PENGUMUMAN TAWARAN ABDIMAS.....	167
159	SOP PENGUMUMAN TAWARAN PENELITIAN.....	168
160	SOP PENGUSULAN PROPOSAL ABDIMAS.....	169
161	SOP PENGUSULAN PROPOSAL PENELITIAN.....	170
162	SOP PENYEDIAAN UP DAN TUP.....	171
163	SOP PENYERAHAN SRIPSI TUGAS AKHIR.....	172
164	SOP PENYUSUNAN KURIKULUM.....	173
165	SOP PENYUSUNAN KURIKULUM DI FAKULTAS.....	174
166	SOP PENYUSUNAN LAPORAN HASIL EVALUASI.....	175
167	SOP PENYUSUNAN LAPORAN KINERJA (LAKIN).....	176
168	SOP PENYUSUNAN PENETAPAN KINERJA.....	177
169	SOP PENYUSUNAN PERATURAN PERUNDANG-UNDANGAN.....	178
170	SOP PENYUSUNAN PERATURAN REKTOR.....	179
171	SOP PENYUSUNAN RENCANA, TUJUAN, OBJEK, DAN RUANG LINGKUP AUDIT.....	180
172	SOP PENYUSUNAN SK REKTOR.....	181
173	SOP PENYUSUNAN TOR DAN RAB.....	182
174	SOP PERBAIKAN SARANA PRASARANA.....	183
175	SOP PERKULIAHAN REGULER.....	184
176	SOP PERMOHONAN PENURUNAN UKT.....	185
177	SOP PERTANGGUNGJAWABAN UP DAN TUP.....	186
178	SOP PINDAH KE PT LAIN.....	187
179	SOP PINDAH PRODI DARI PT LAIN.....	188
180	SOP PINDAH PRODI DILUAR UTM.....	189
181	SOP PINDAH PRODI LINTAS FAKULTAS.....	190
182	SOP PINDAH PRODI SATU FAKULTAS.....	191
183	SOP PRAKTEK KERJA LAPANGAN.....	192
184	SOP PRAKTIKUM.....	193
185	SOP PREVENTIVE MAINTENANCE PERANGKAT.....	194
186	SOP PUBLIKASI HASIL PENELITIAN ABDIMAS DI JURNAL PROSIDING LAINNYA.....	195
187	SOP REGISTRASI MAHASISWA BARU JALUR MANDIRI.....	196
188	SOP REGISTRASI MHS BARU JALUR SBMPTN.....	197
189	SOP REGISTRASI MHS BARU JALUR SNMPTN.....	198
190	SOP REGISTRASI ONLINE (SIKAD).....	199



191	SOP REVISI RKAKL.....	200
192	SOP RKAKL DIPA.....	201
193	SOP SELEKSI PENUNJUKAN ABDIMAS .....	202
194	SOP SELEKSI PENUNJUKAN PENELITIAN.....	203
195	SOP SEMINAR PROPOSAL TUGAS AKHIR .....	204
196	SOP SERAH TERIMA DAN PELANTIKAN.....	205
197	SOP SURAT IJIN TIDAK MASUK KULIAH (DISPENSASI) KEGIATAN DI LUAR KAMPUS.....	206
198	SOP SURAT IJIN TIDAK MASUK KULIAH (DISPENSASI) MELAKUKAN KEGIATAN DI DALAM KAMPUS .....	207
199	SOP SURAT KELUAR FAKULTAS.....	208
200	SOP SURAT KELUAR PIMPINAN .....	209
201	SOP SURAT MASUK FAKULTAS .....	210
202	SOP SURAT MASUK PIMPINAN.....	211
203	SOP TEST OF ENGLISH AS A FOREIGN LANGUAGE (TOEFL).....	212
204	SOP TINDAK LANJUT .....	213
205	SOP TUGAS AKHIR.....	214
206	SOP UJIAN TUGAS AKHIR.....	215
207	SOP UNGGAH MANDIRI.....	216
208	SOP UPACARA PERINGATAN HARI BESAR NASIONAL.....	217
209	SOP VERIFIKASI RAPORT JALUR SNMPTN .....	218



# 1 L0 - Peta Proses Bisnis Universitas Trunojoyo Madura

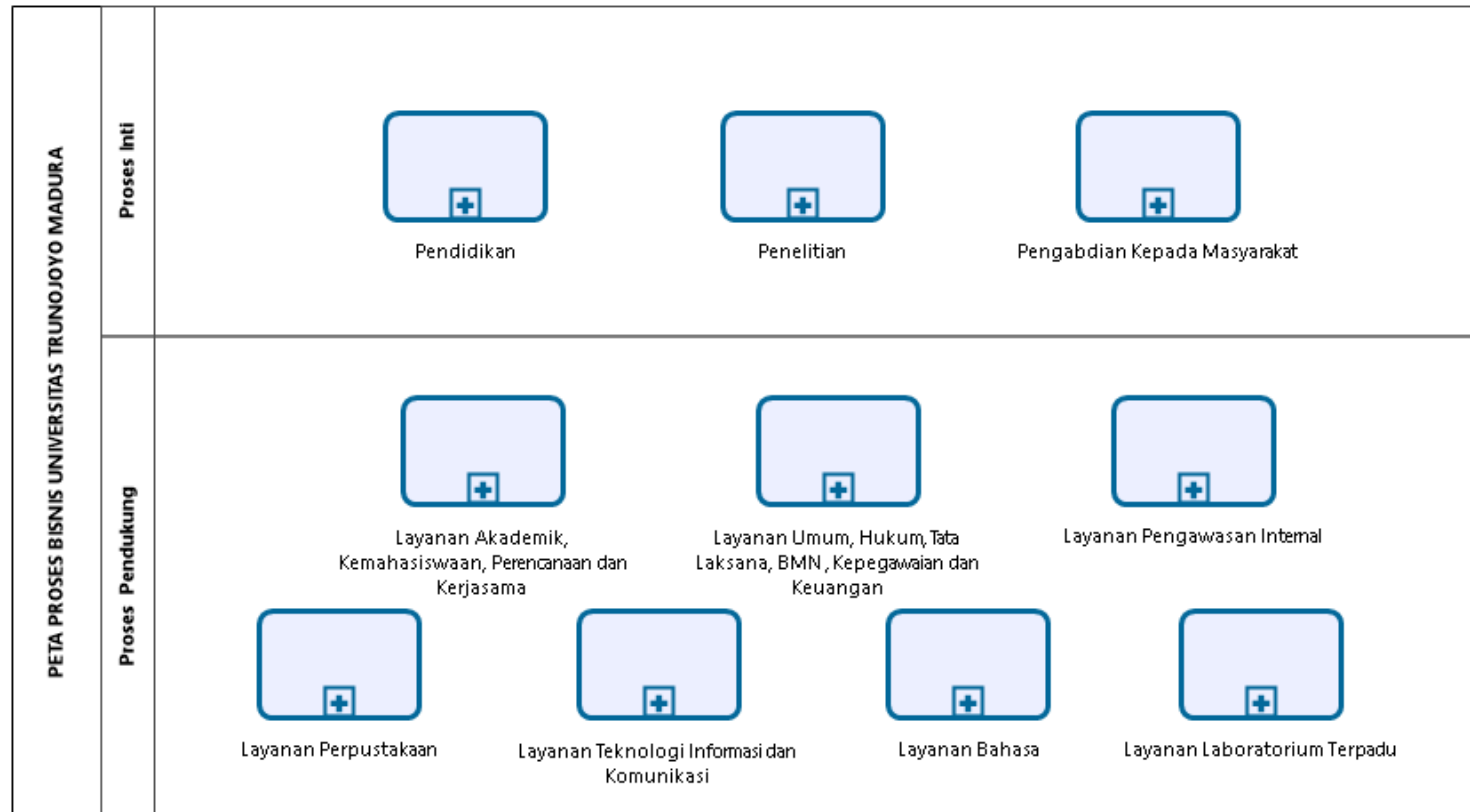



## 2 L1 - Pendidikan

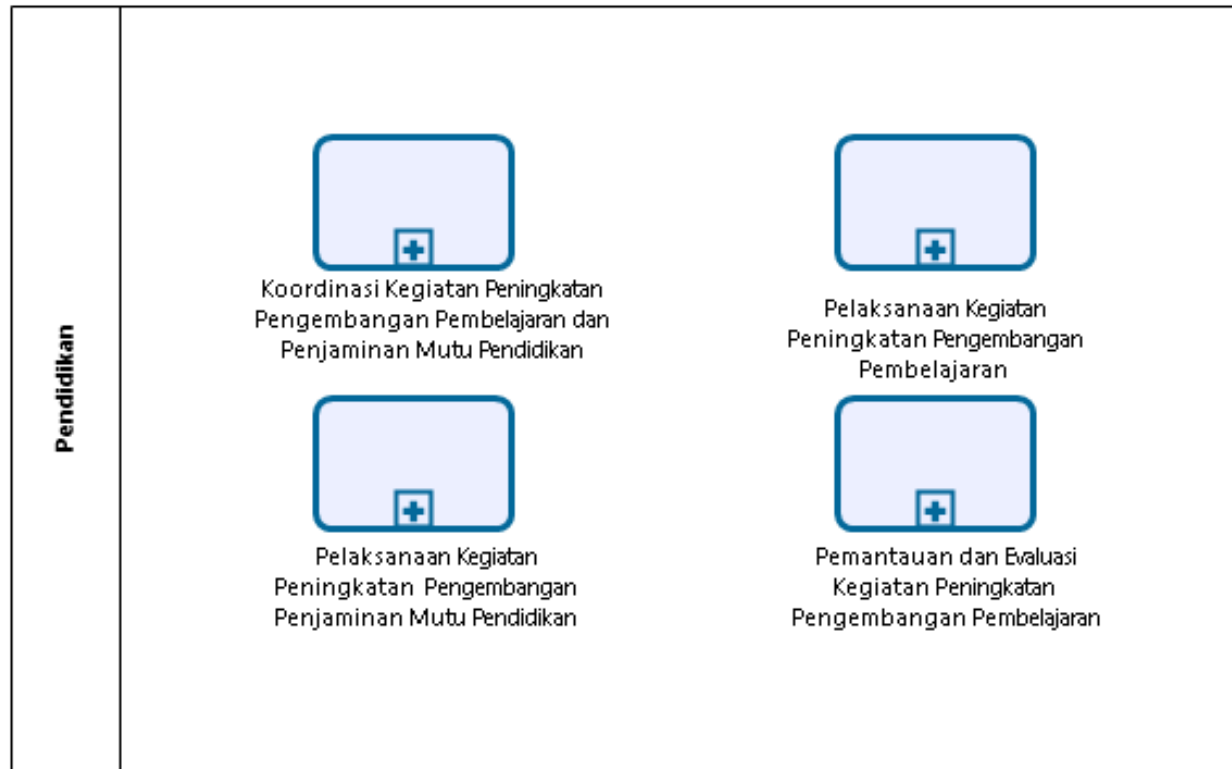



### 3 L2 - Koordinasi Kegiatan Peningkatan Pengembangan Pembelajaran dan Penjaminan Mutu Pendidikan

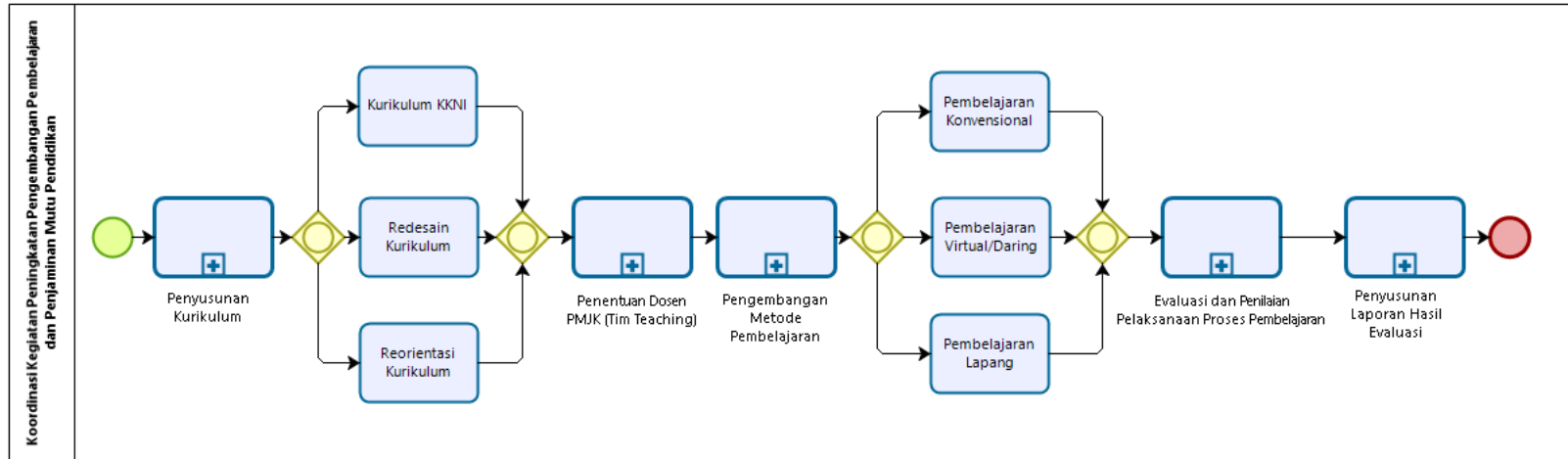



## 4 L2 - Pelaksanaan Kegiatan Peningkatan Pengembangan Pembelajaran

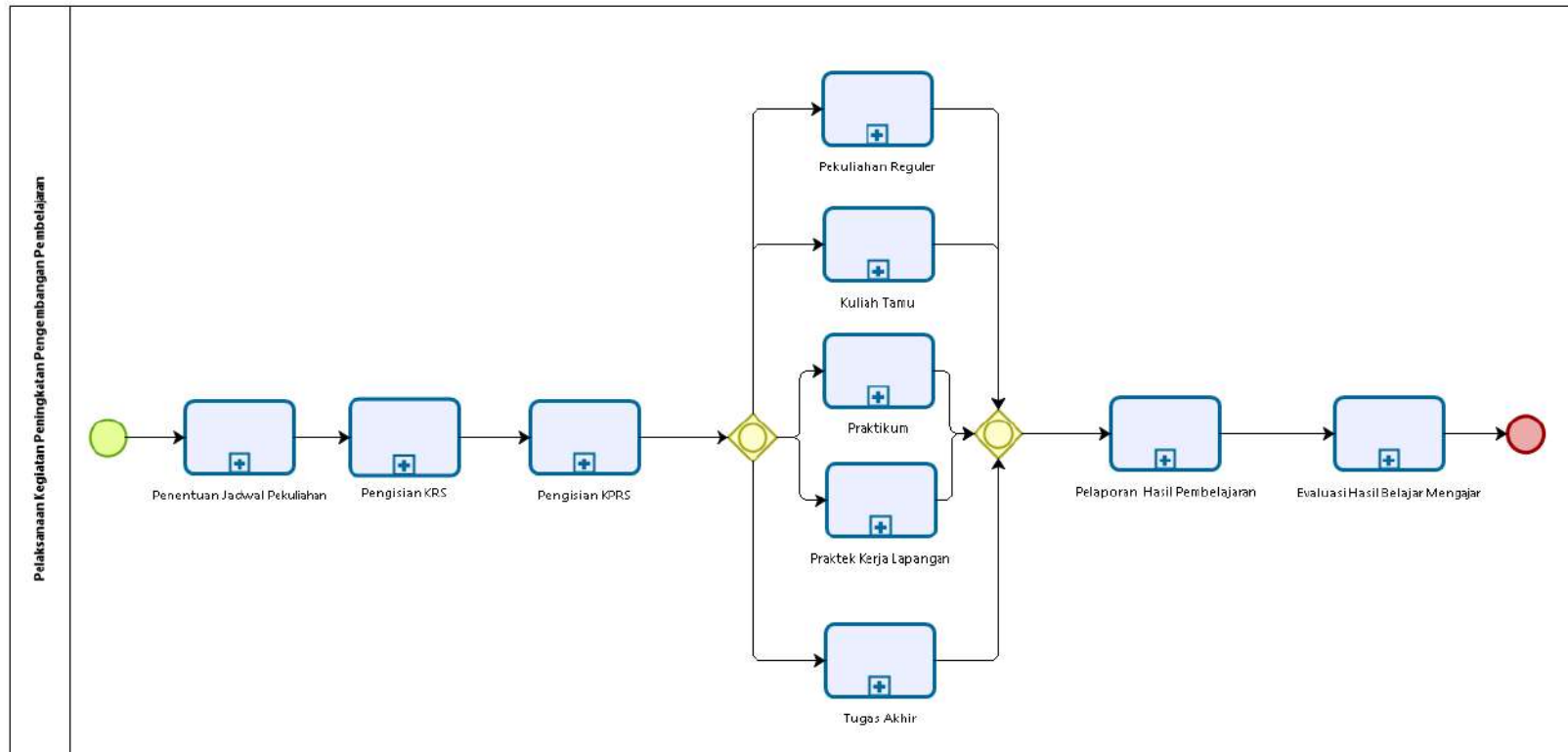



## 5 L2 - Pelaksanaan Kegiatan Peningkatan Pengembangan Penjaminan Mutu Pendidikan

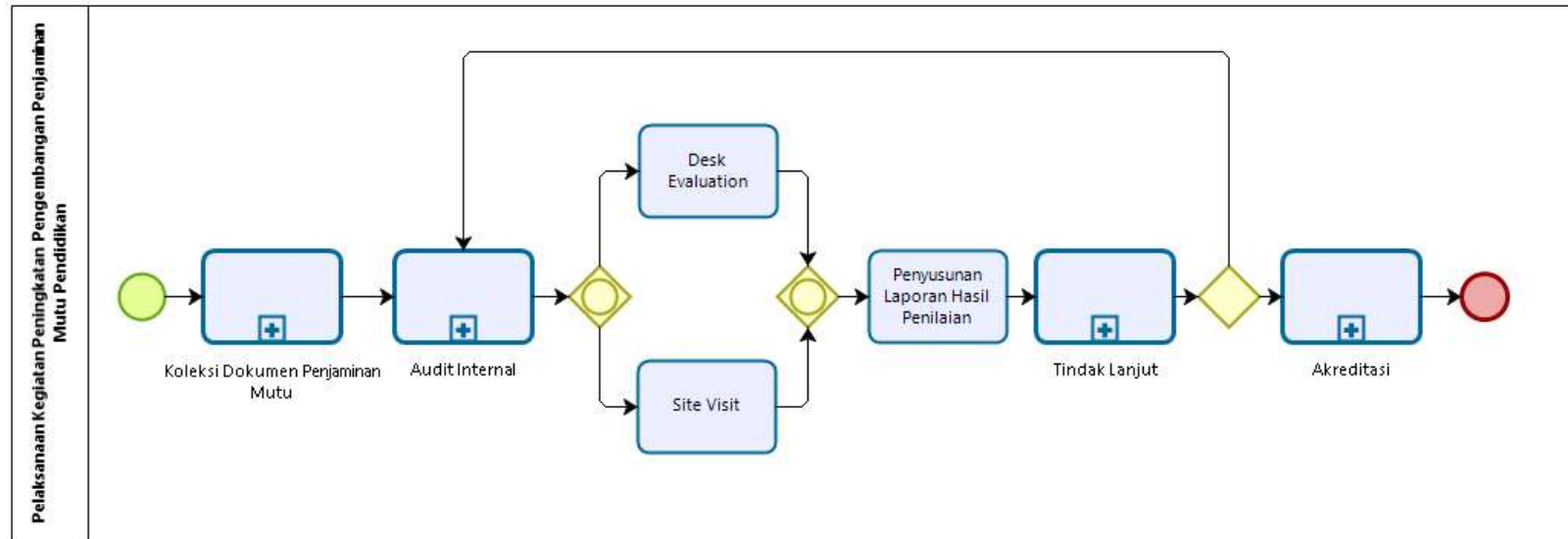



## 6 L2 - Pemantauan dan Evaluasi Kegiatan Peningkatan Pengembangan Pembelajaran

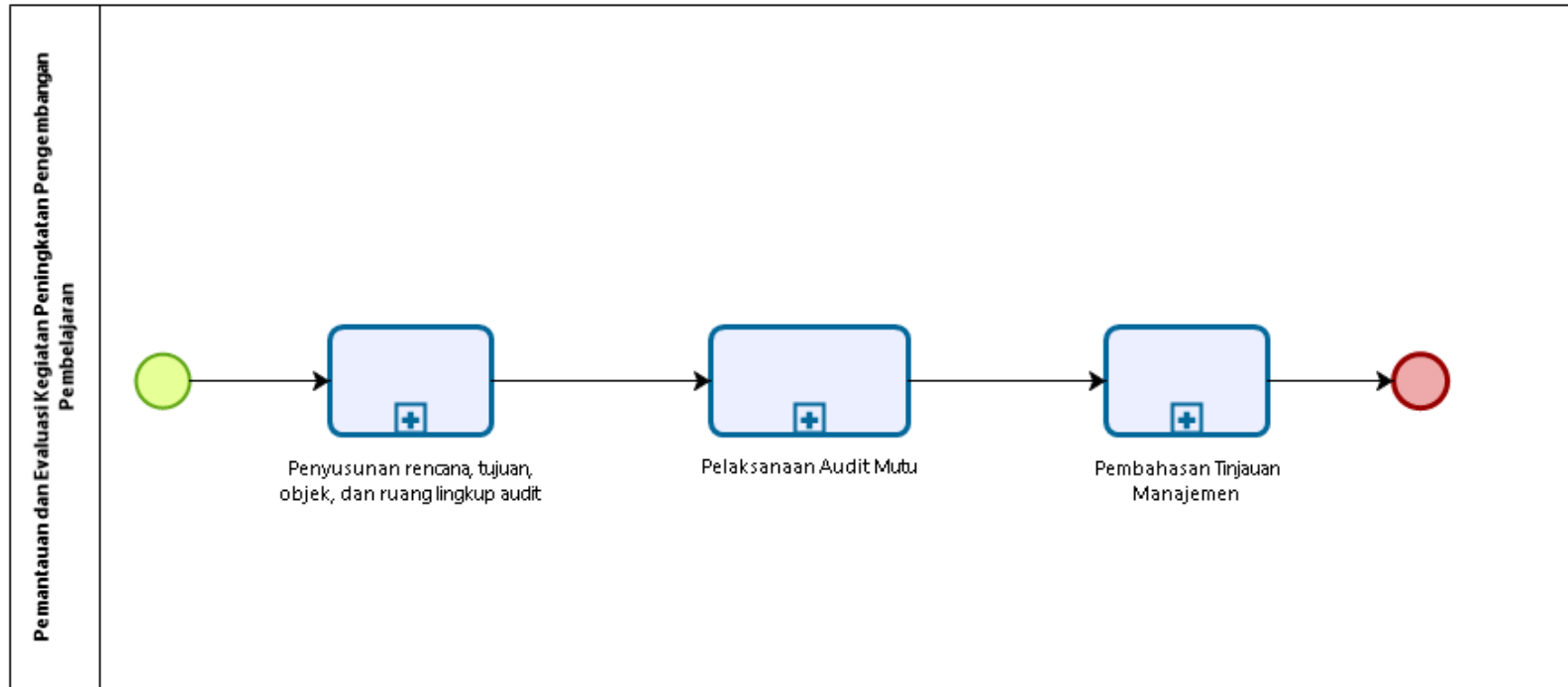





## 7 L1 - Penelitian

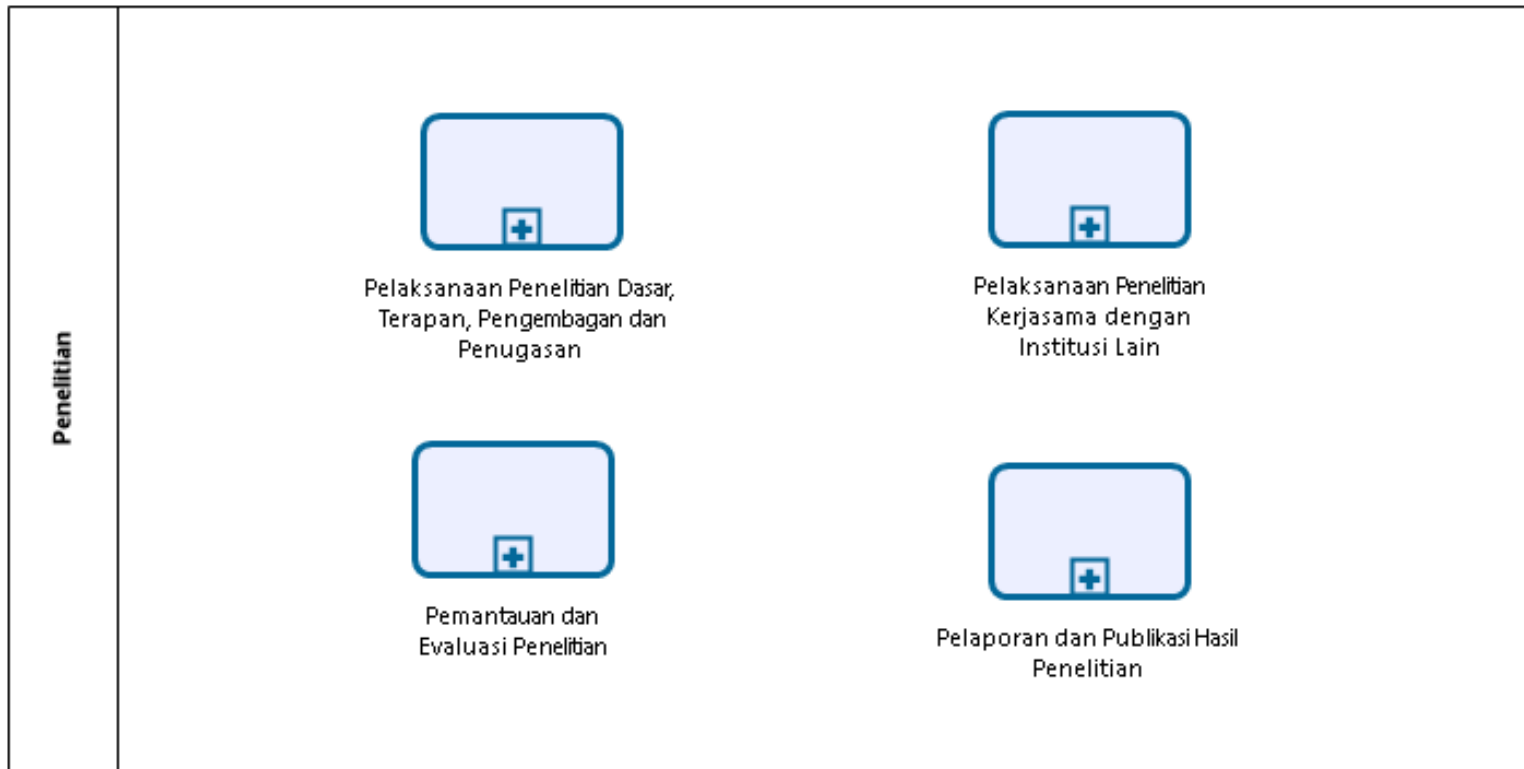



## 8 L2 - Pelaksanaan Penelitian Dasar, Terapan, Pengembangan dan Penugasan

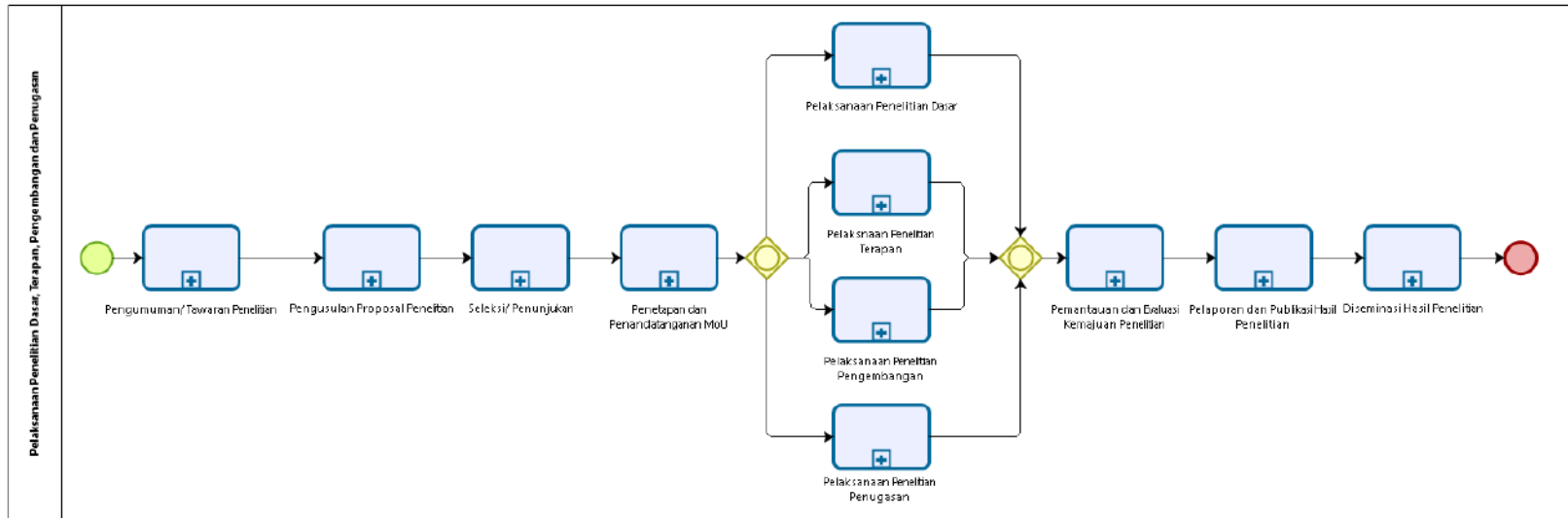



## 9 L2 - Pelaksanaan Penelitian Kerjasama dengan Institusi Lain

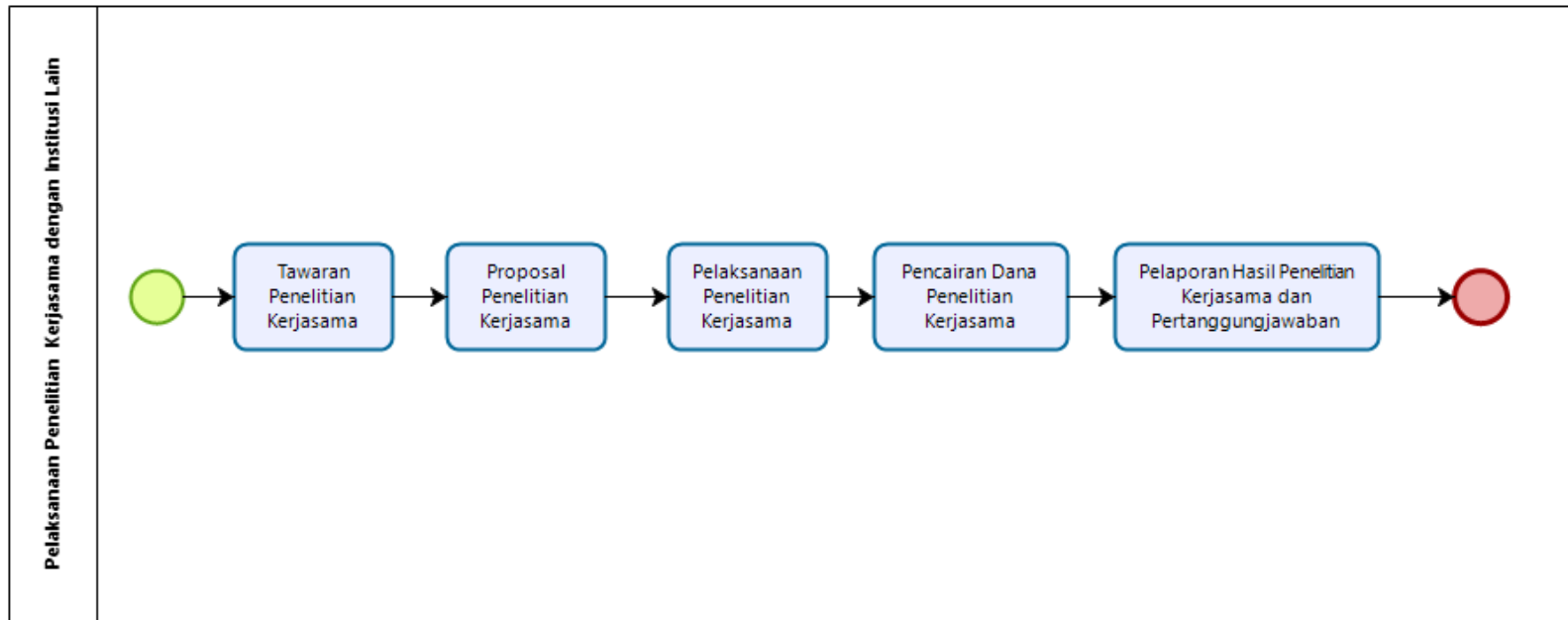



## 10 L2 - Pemantuan dan Evaluasi Penelitian

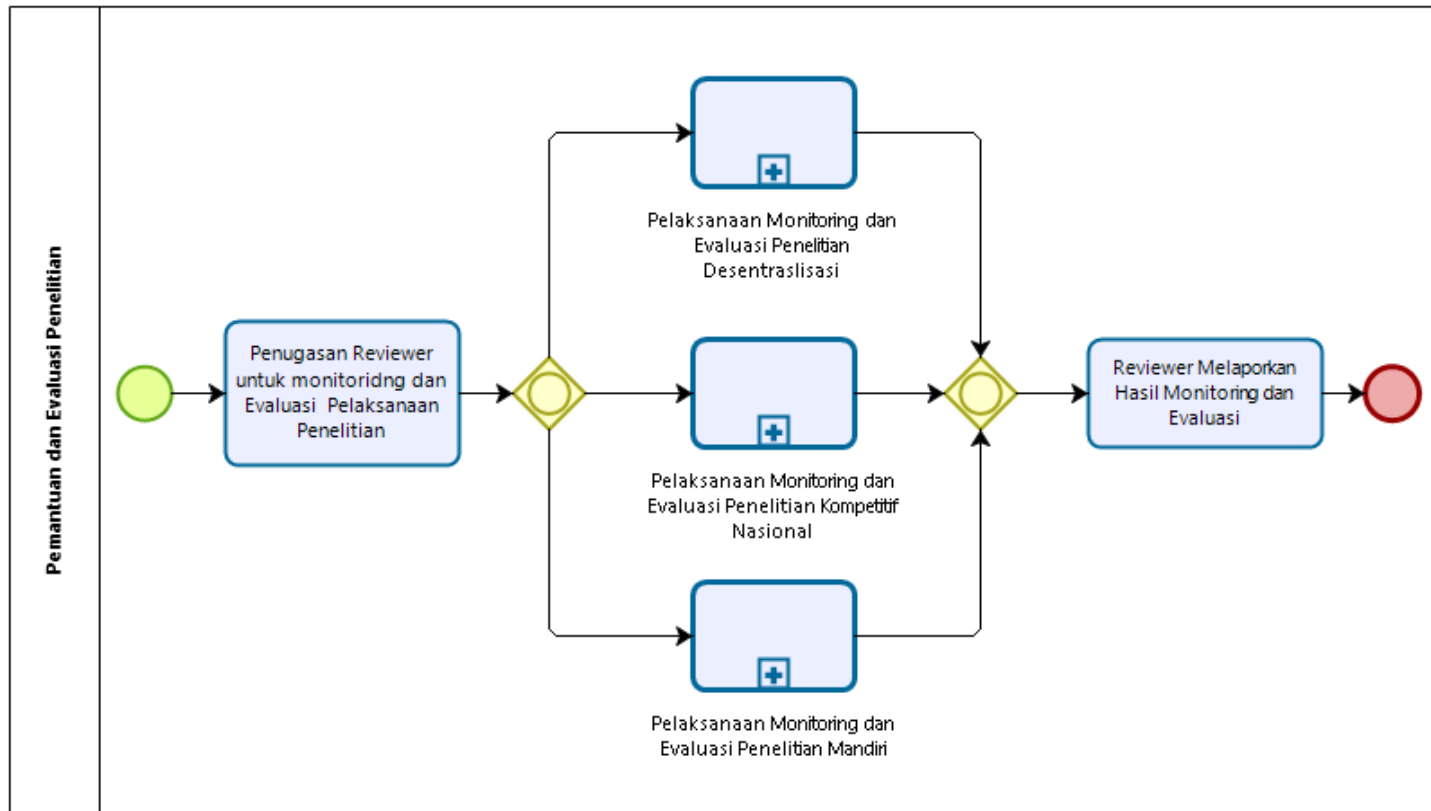



## 11 L2 - Pelaporan dan Publikasi Hasil Penelitian

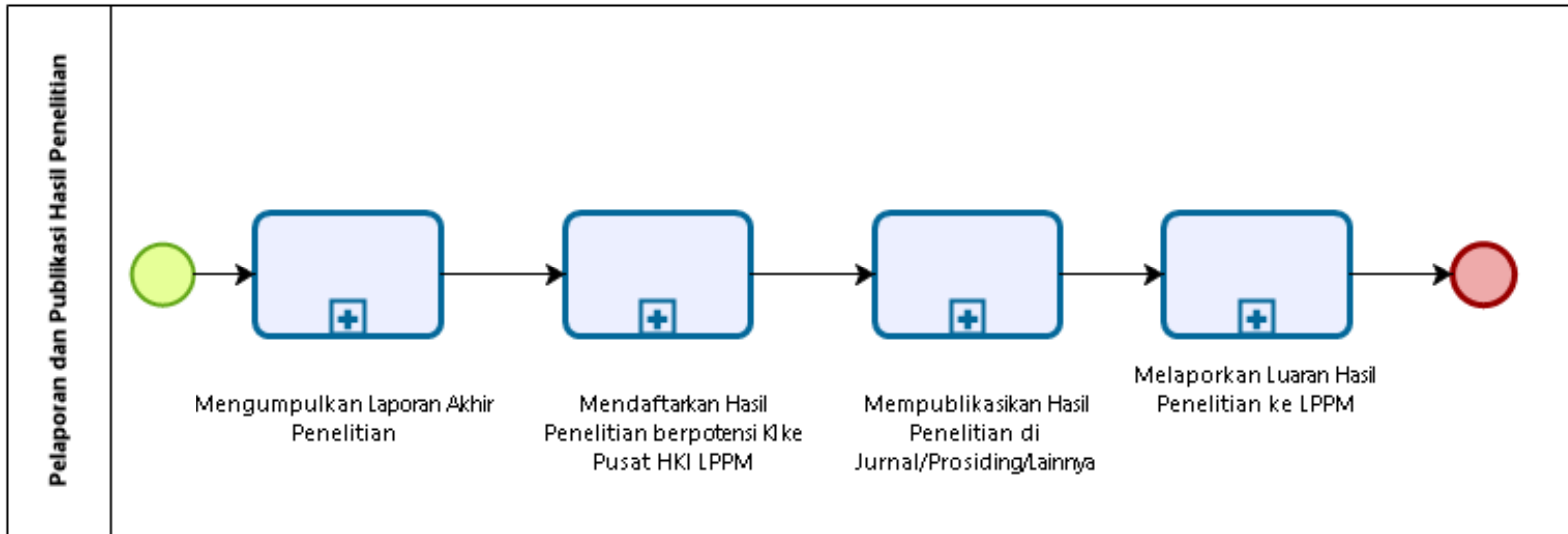



## 12 L1 - Pengabdian kepada Masyarakat





### 13 L2 - Pelaksanaan Pengabdian kepada Masyarakat

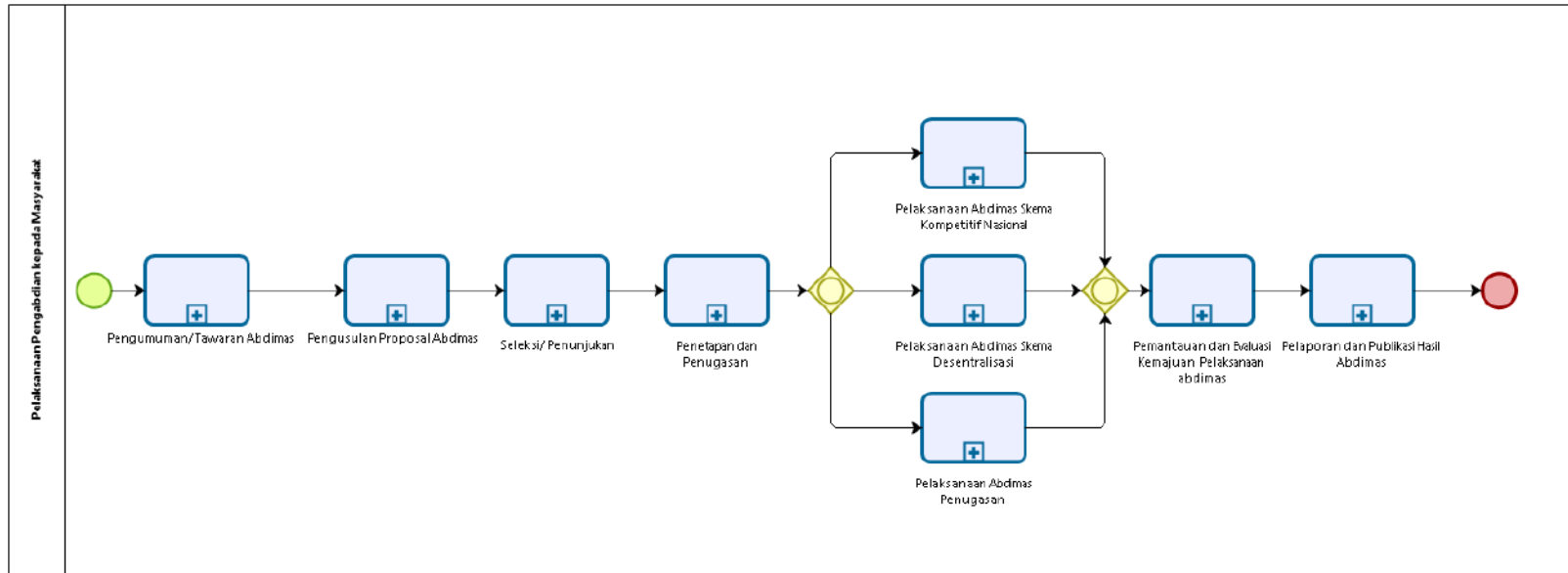



## 14 L2 - Pelaksanaan Pengabdian kepada Masyarakat Kerjasama dengan Institusi Lain

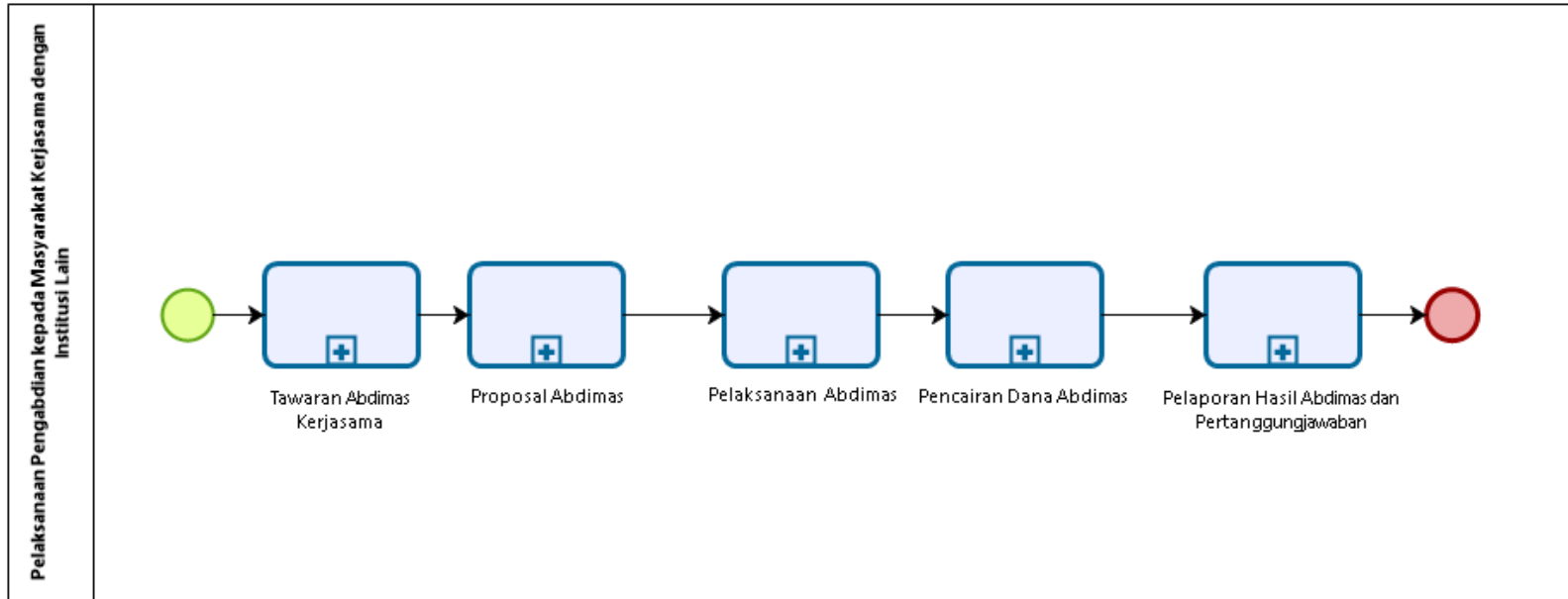







## 15 L2 - Pemantauan dan Evaluasi Pengabdian kepada Masyarakat

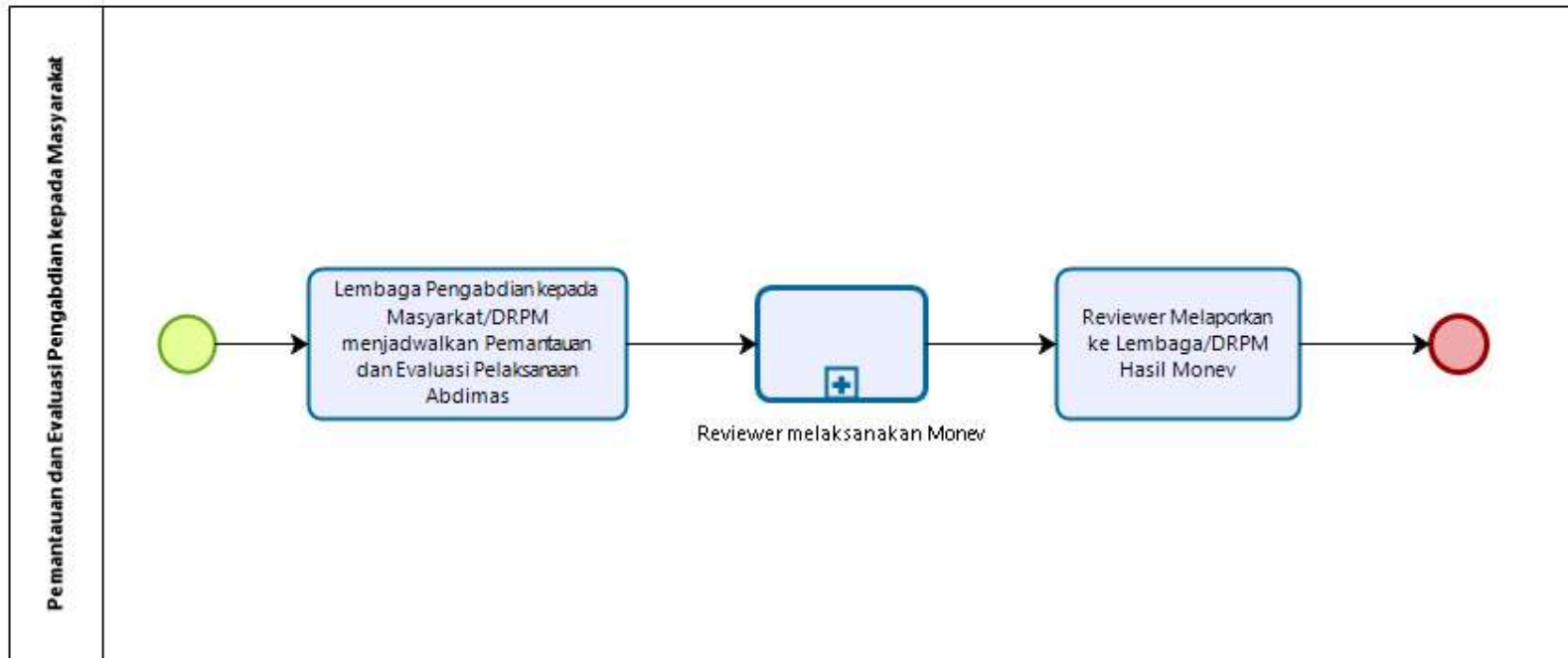



## 16 L2 - Pelaporan dan Publikasi Hasil Pengabdian kepada Masyarakat

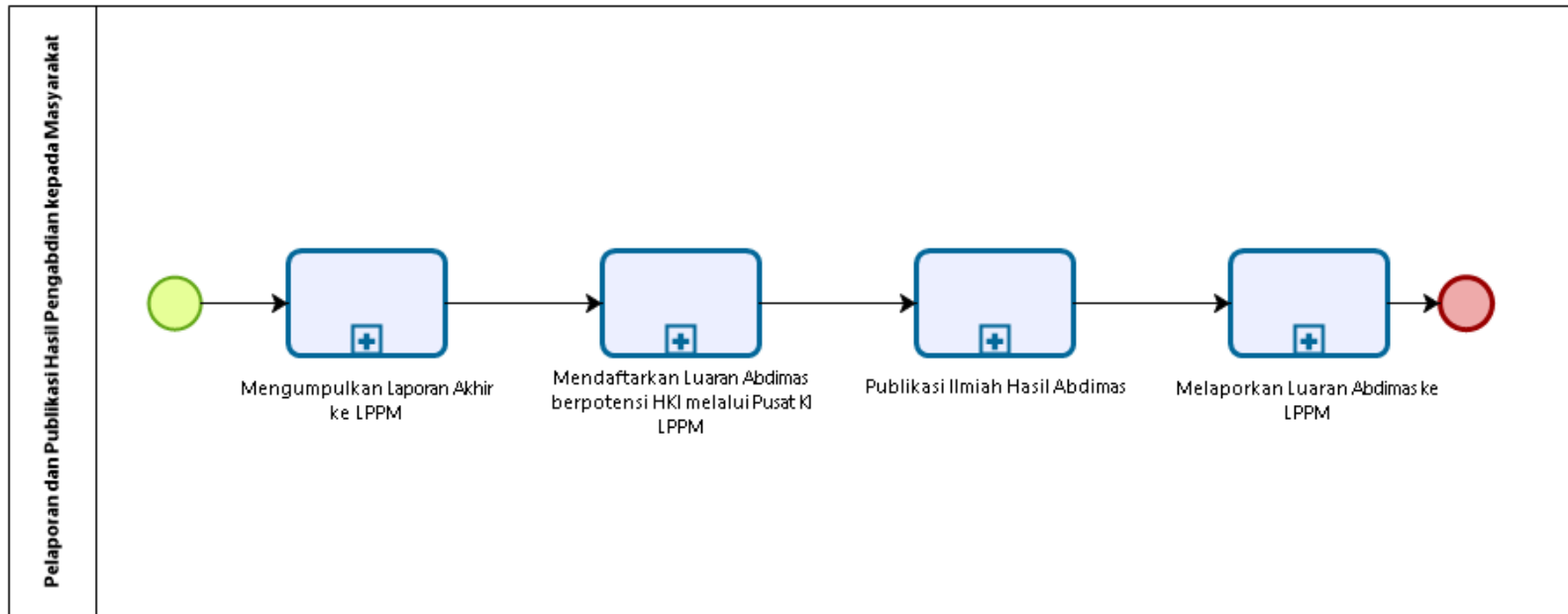



## 17 L1 - Layanan Akademik dan Kemahasiswaan

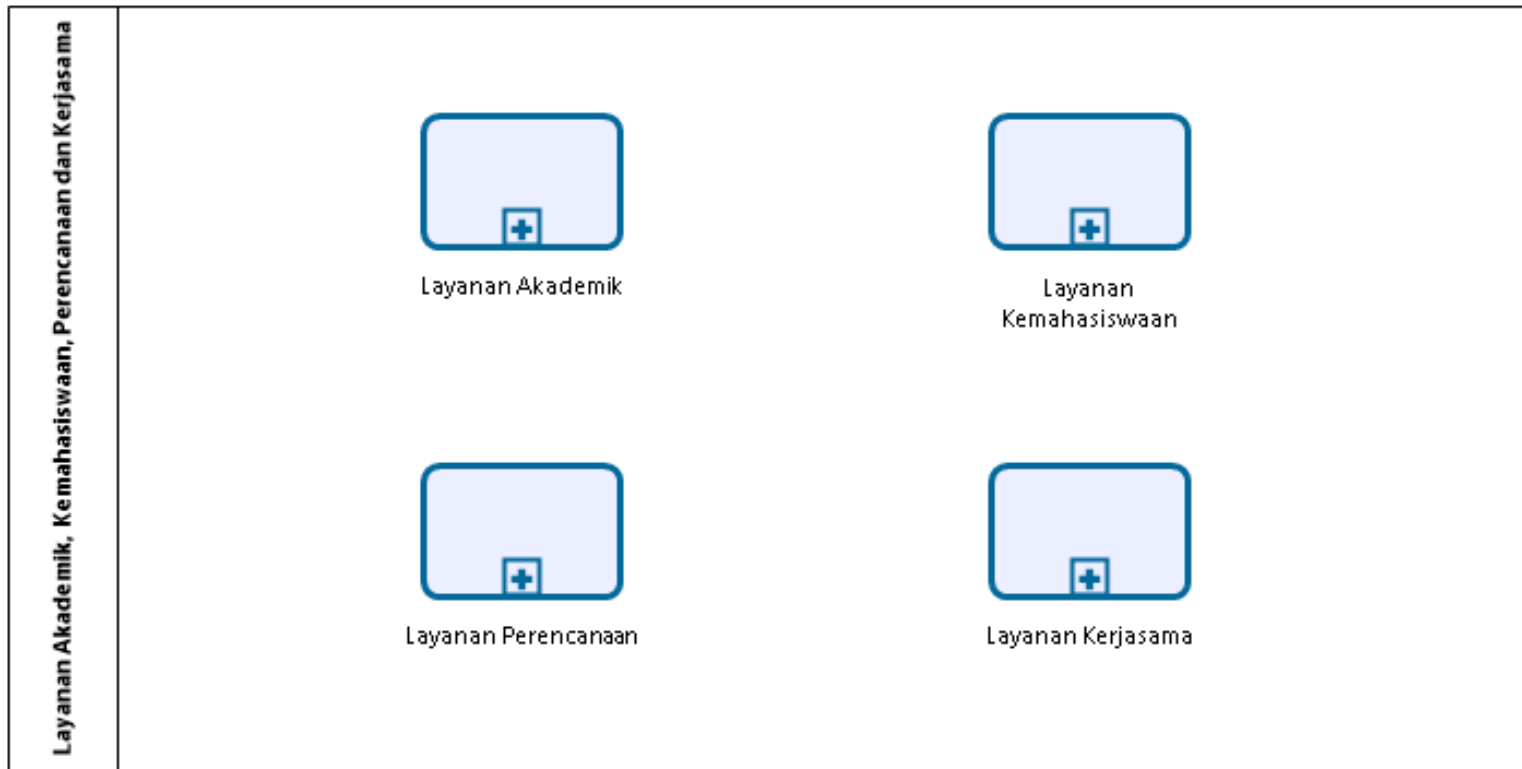



## 18 L2 - Layanan Akademik

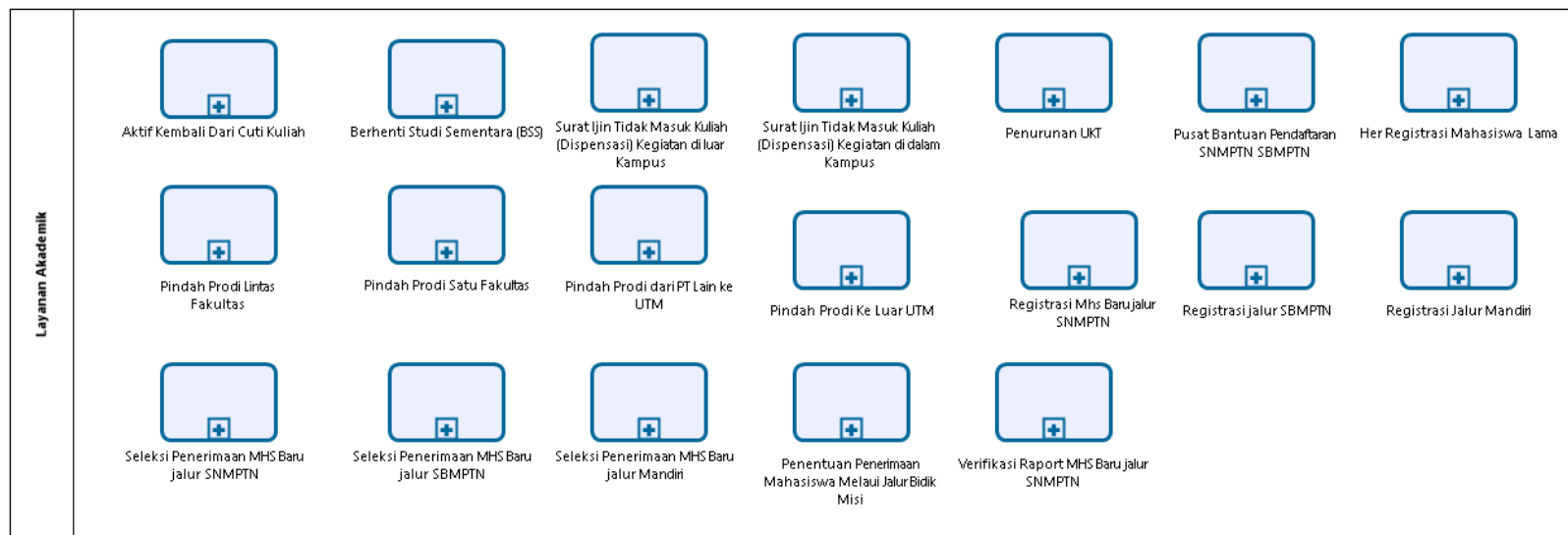



## 19 L2 - Layanan Kemahasiswaan

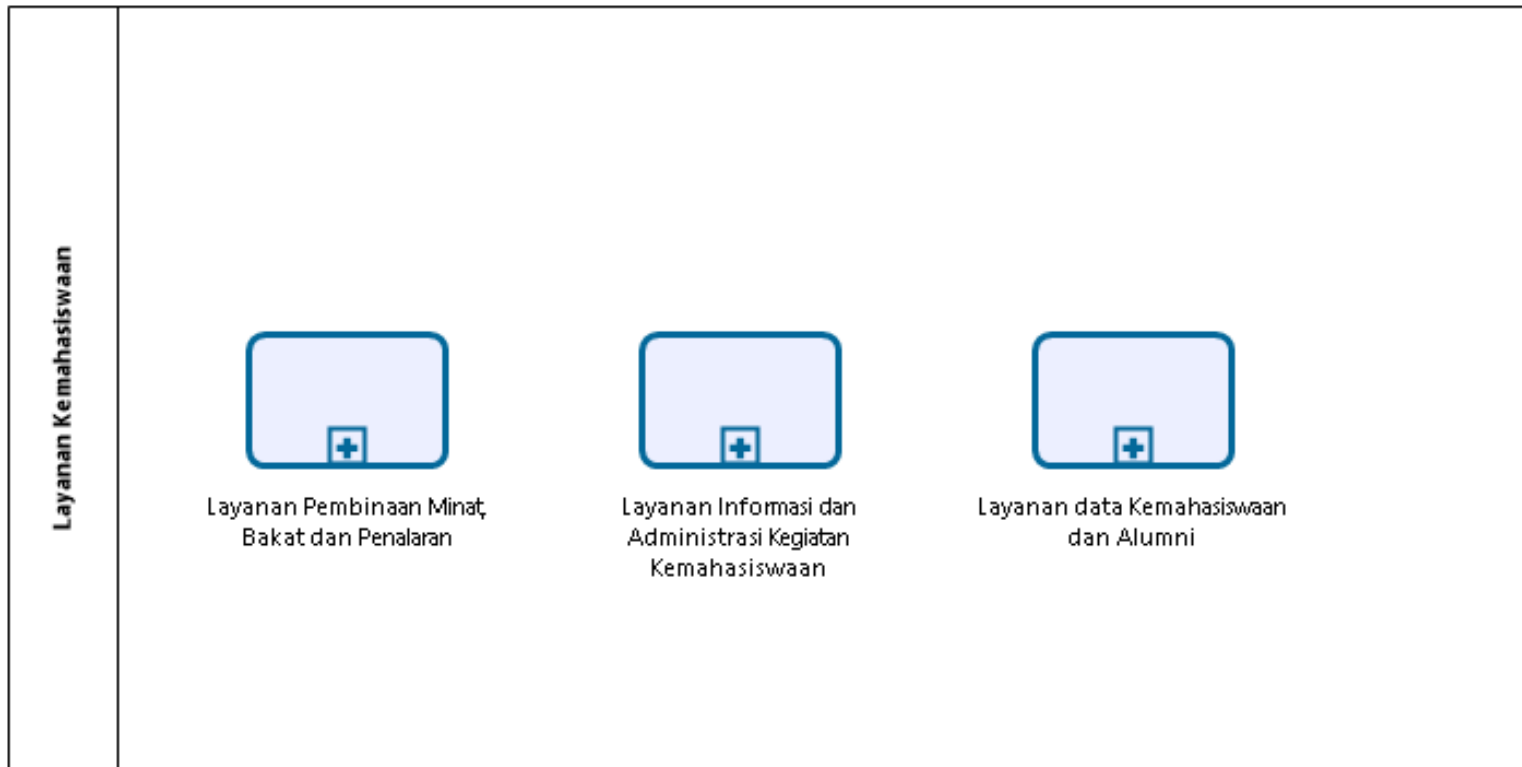



## 20 L2 - Layanan Perencanaan

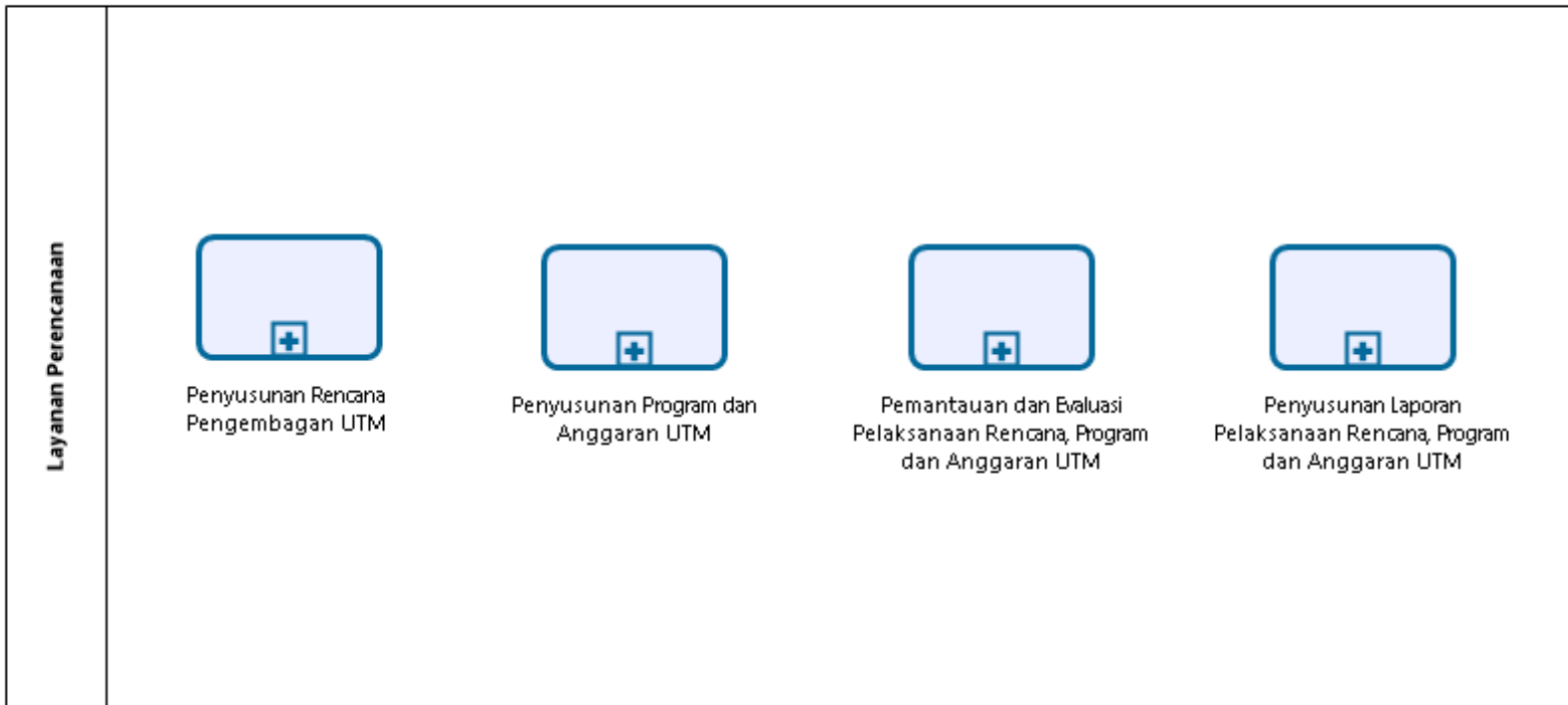



## 21 L2 - Layanan Kerjasama

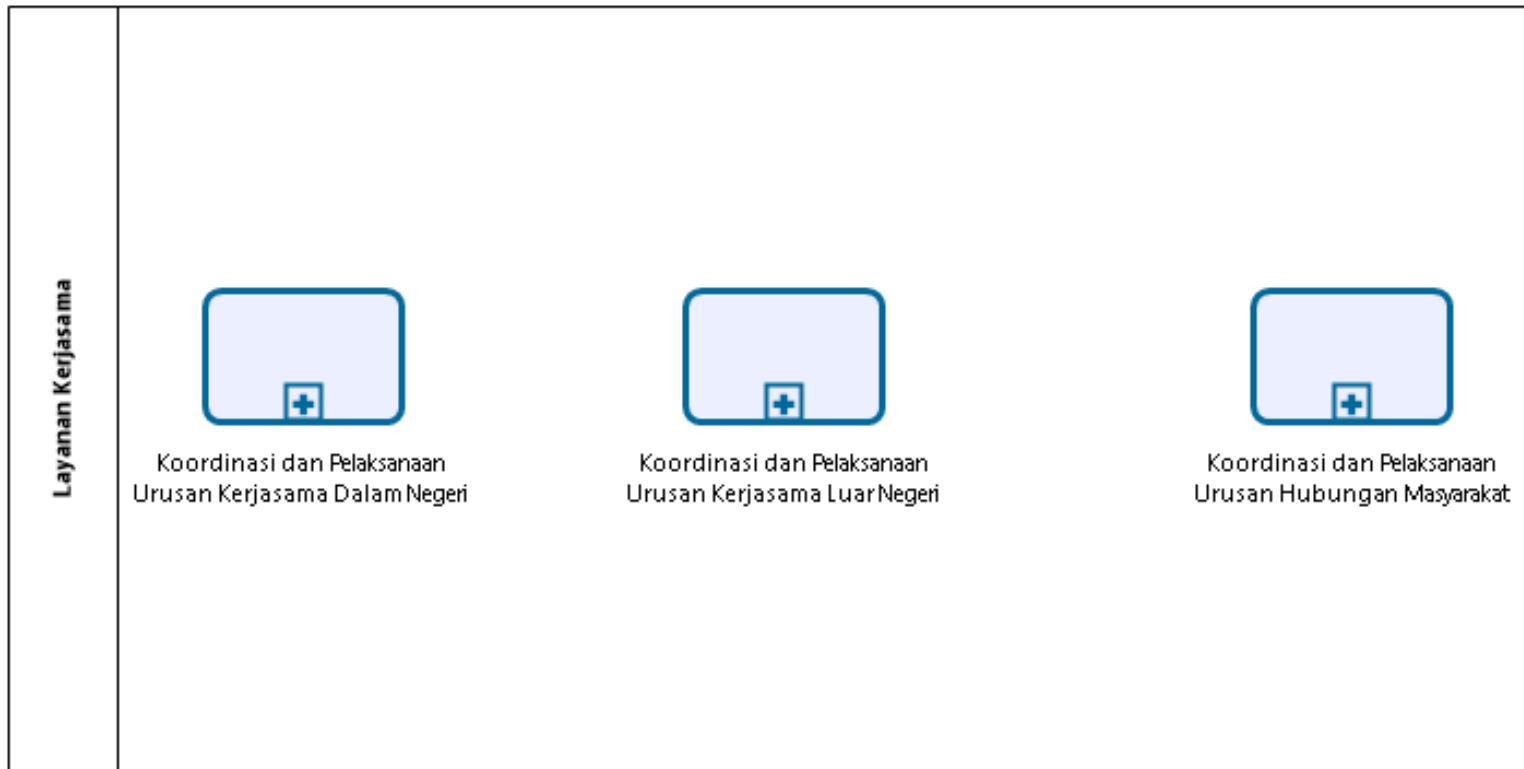





## 22 L1 - Layanan Umum, Hukum, Tata Laksana, BMN , Kepegawaian dan Keuangan

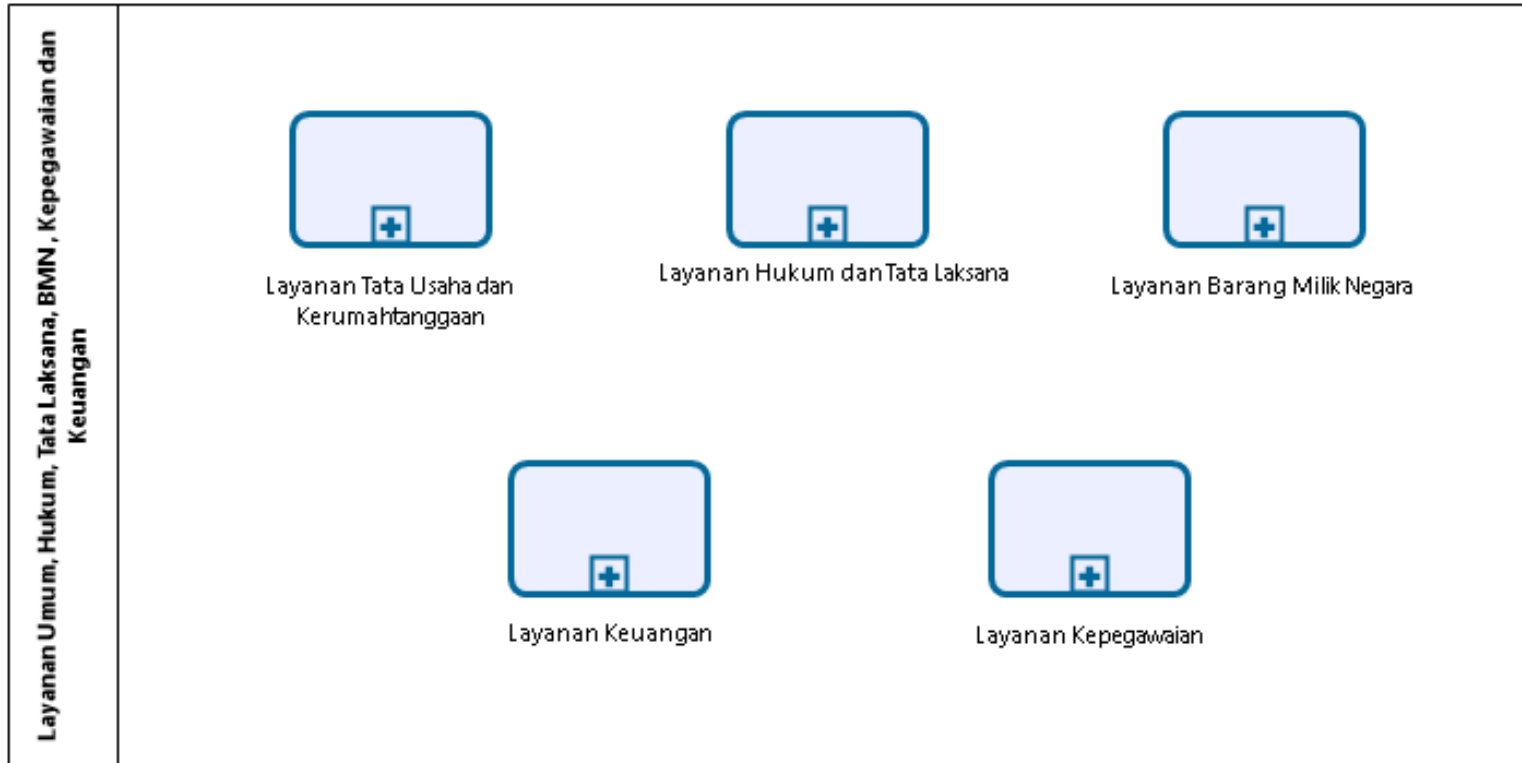



## 23 L2 - Layanan Tata Usaha dan Kerumahtanggaan

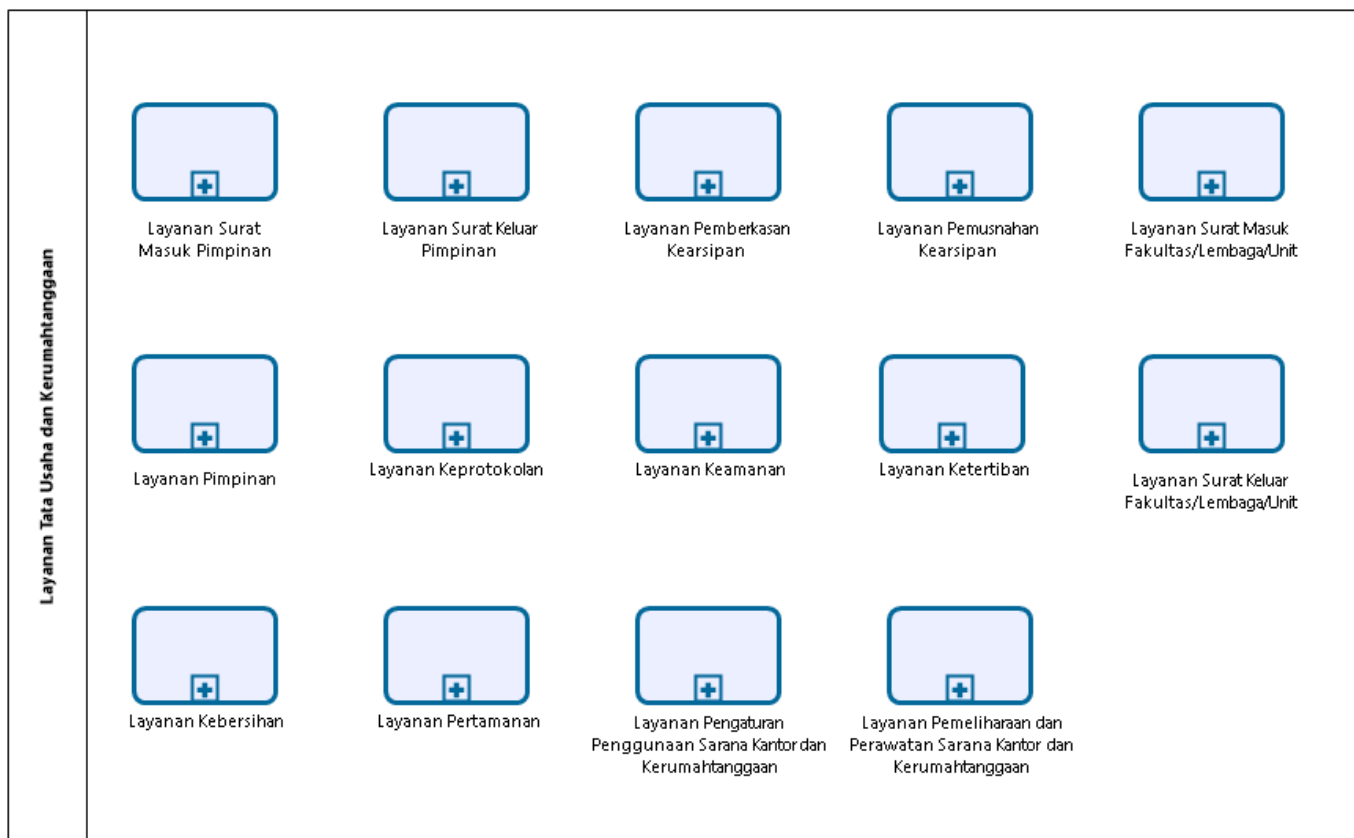



## 24 L2 Layanan Hukum dan Tata Laksana

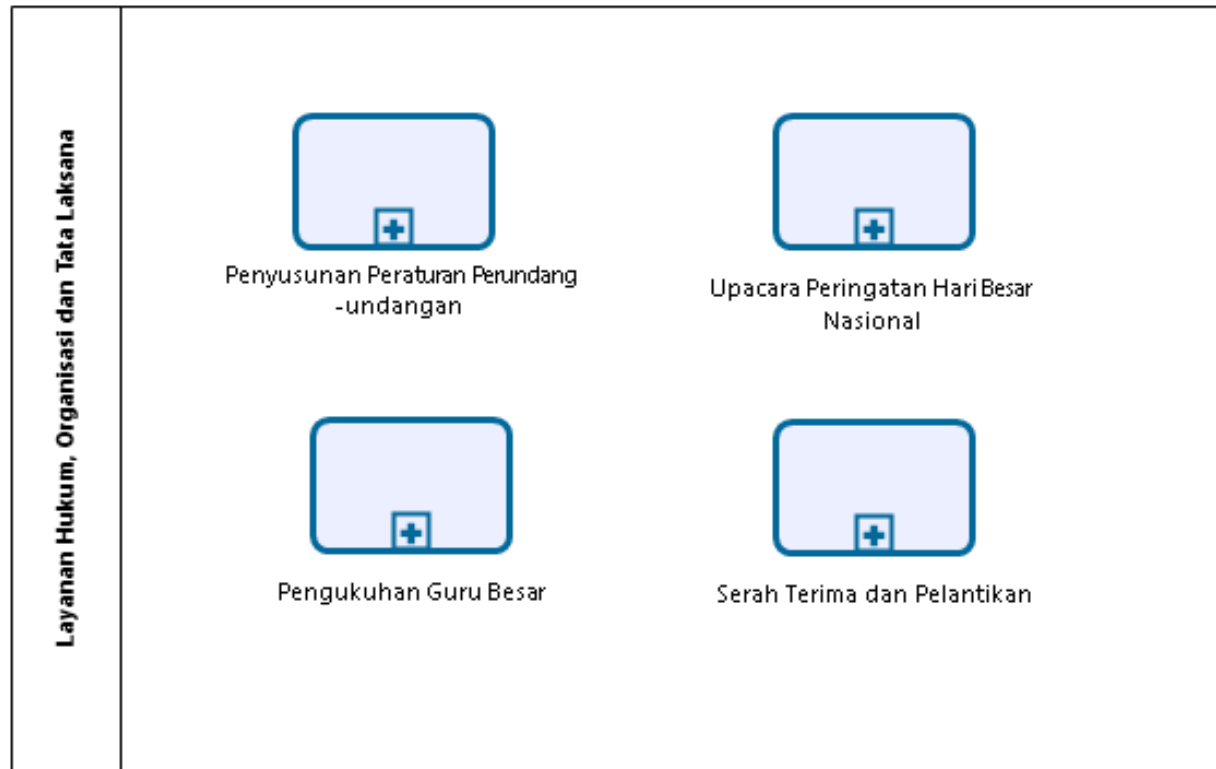



## 25 L2 Layanan Barang Milik Negara

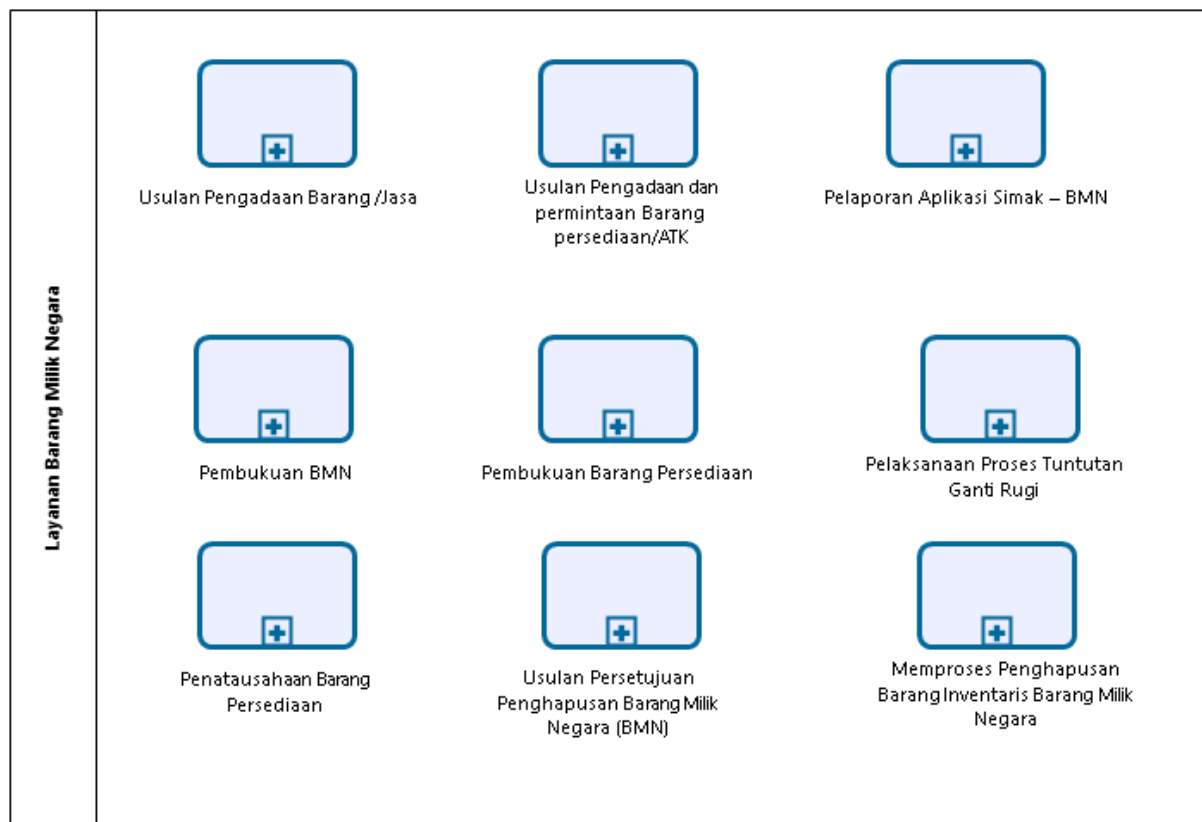



## 26 L2 - Layanan Kepegawaian

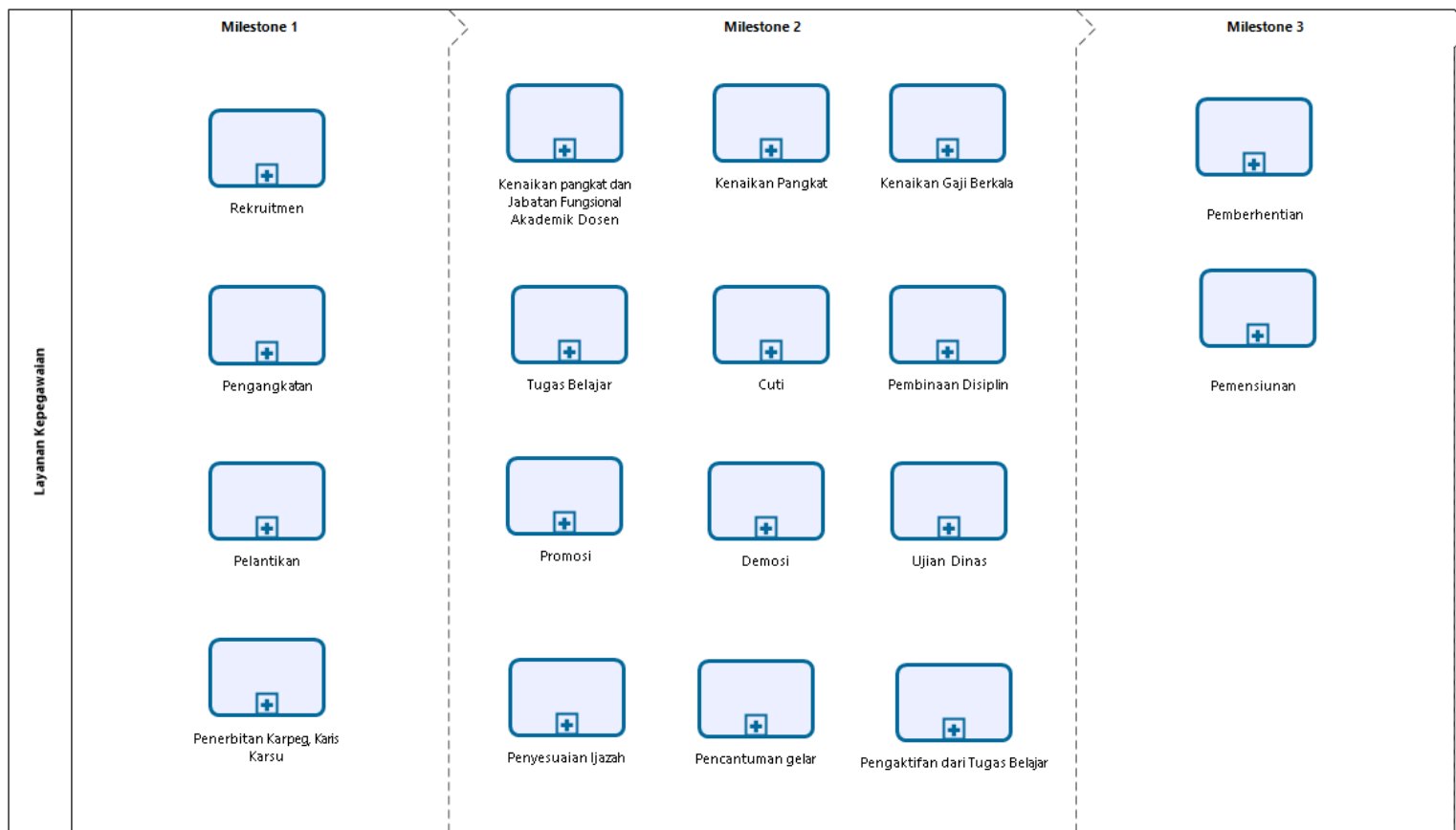



## 27 L2 - Layanan Keuangan

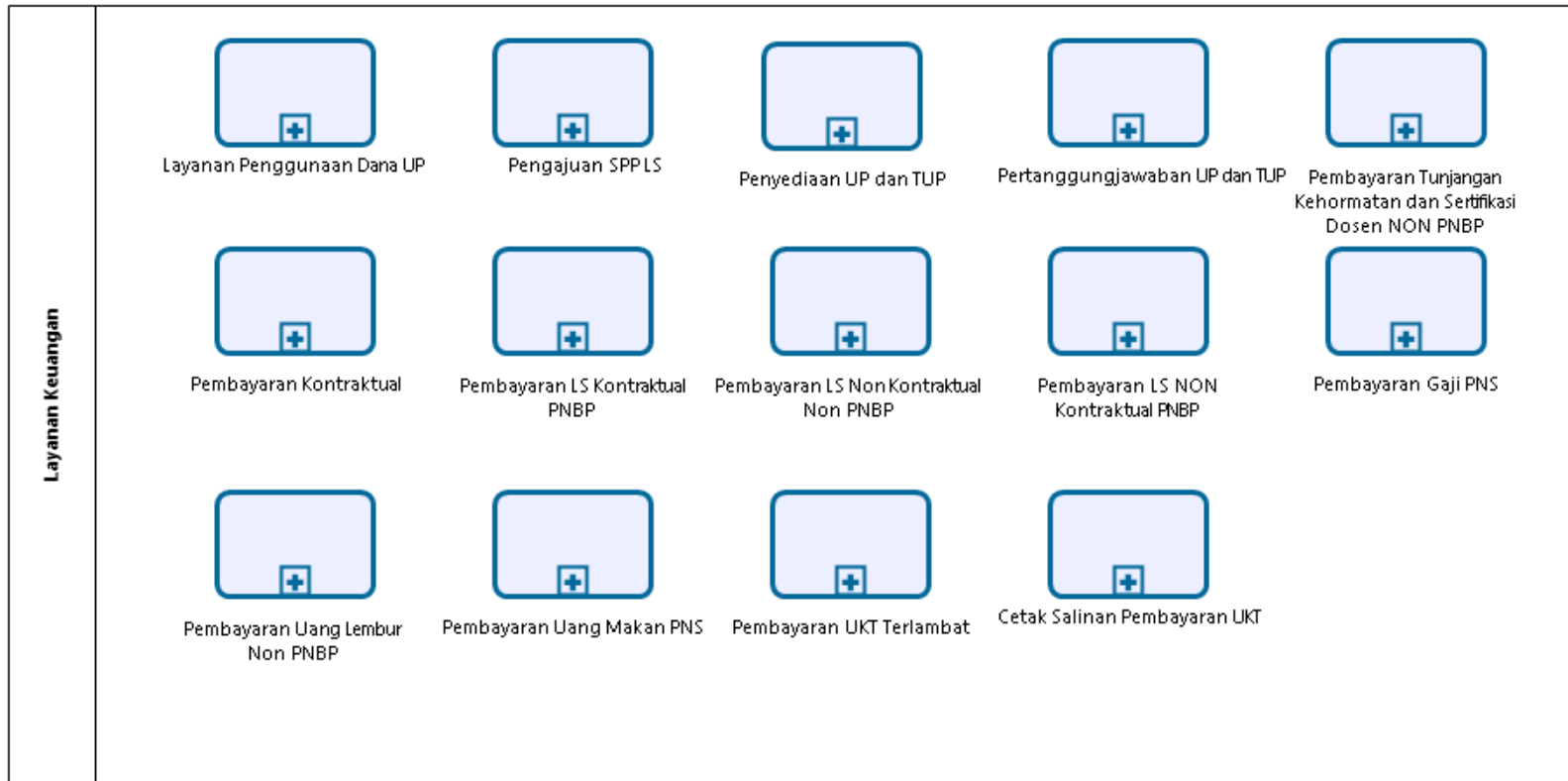



## 28 L1 - Layanan Perpustakaan

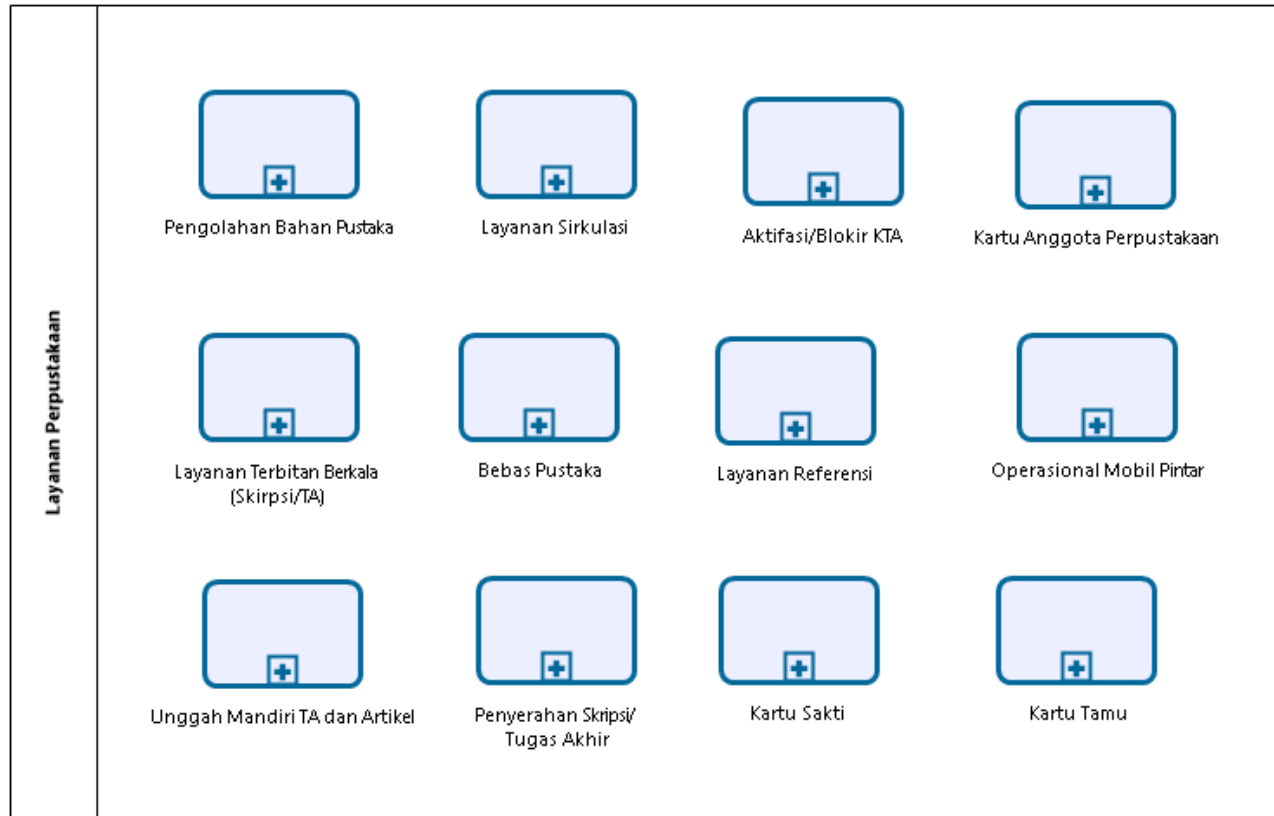



## 29 L2 - Layanan Sirkulasi

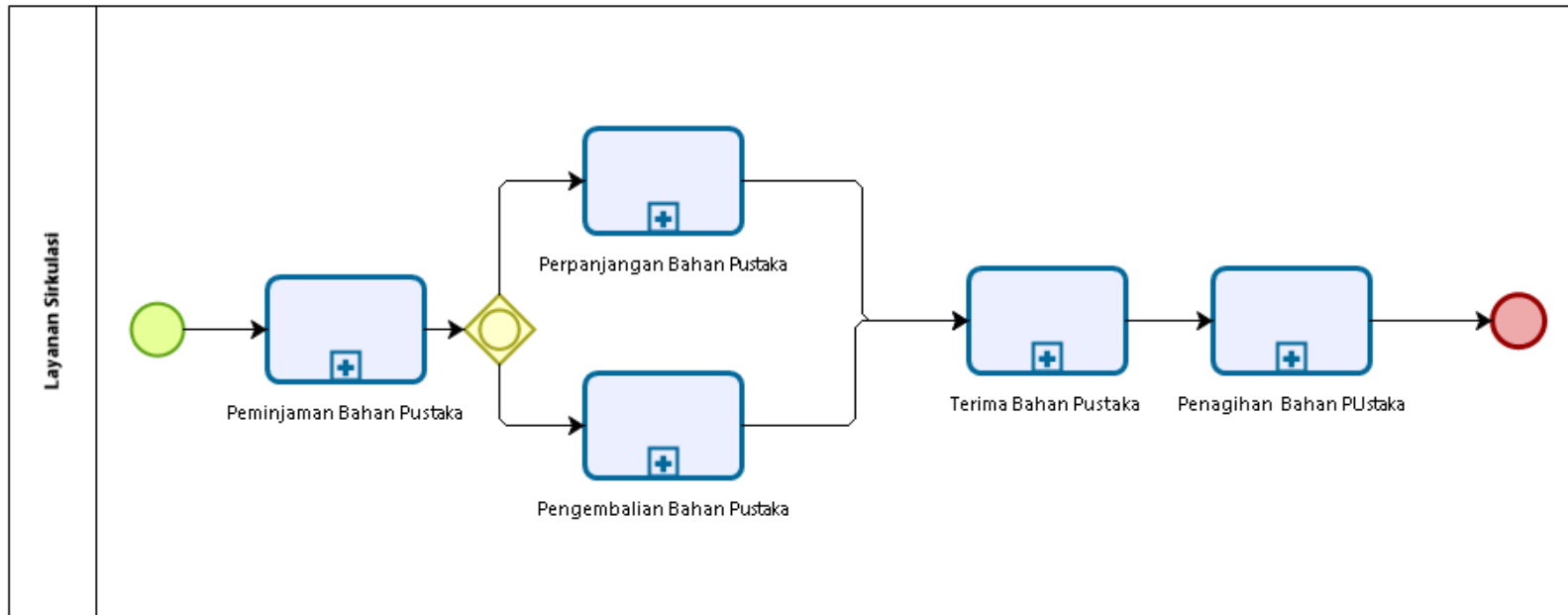





## 30 L1 - Layanan Teknologi Informasi dan Komunikasi

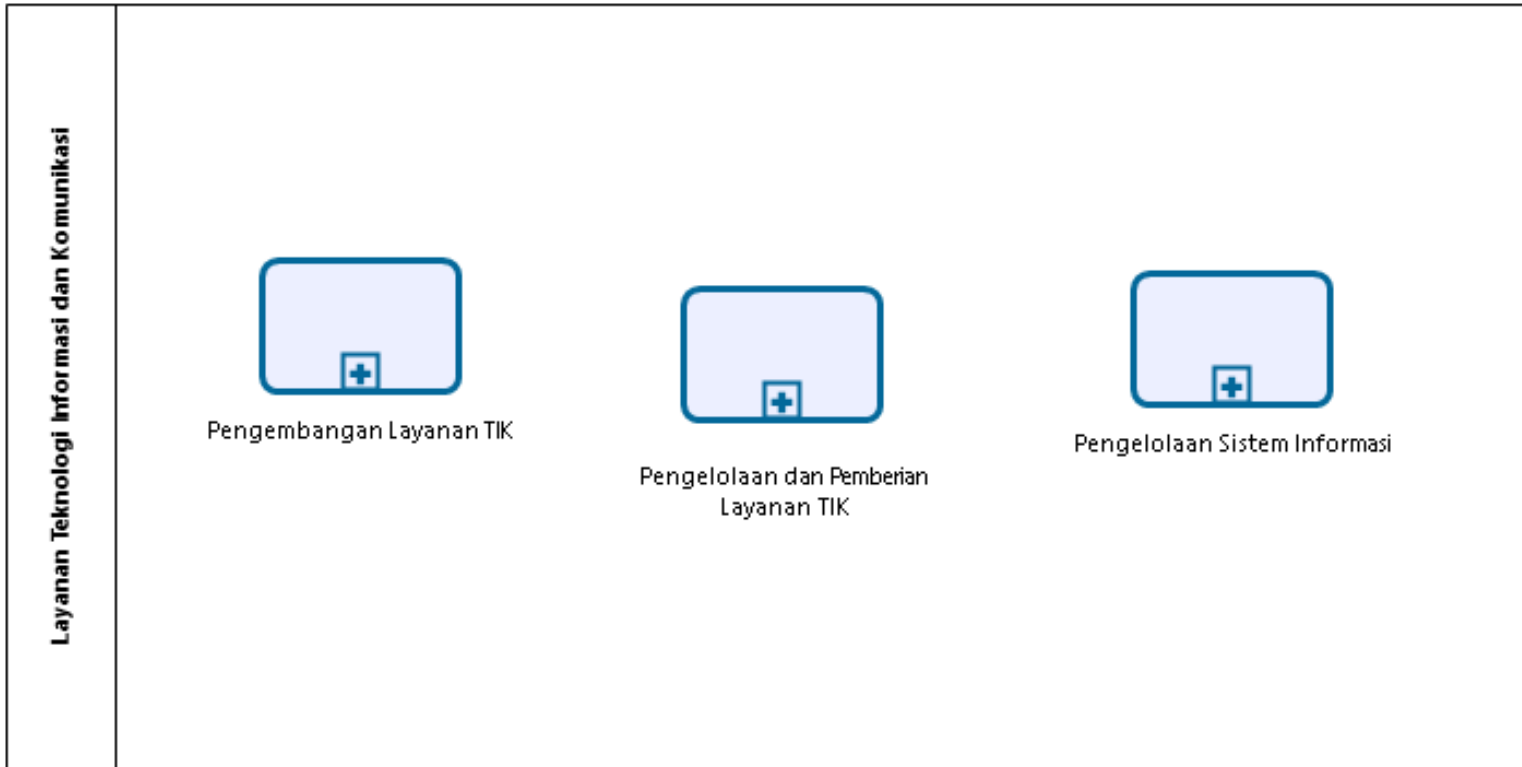



## 31 L2 - Pengembangan Layanan TIK





## 32 L2 - Pengelolaan dan Pemberian Layanan TIK

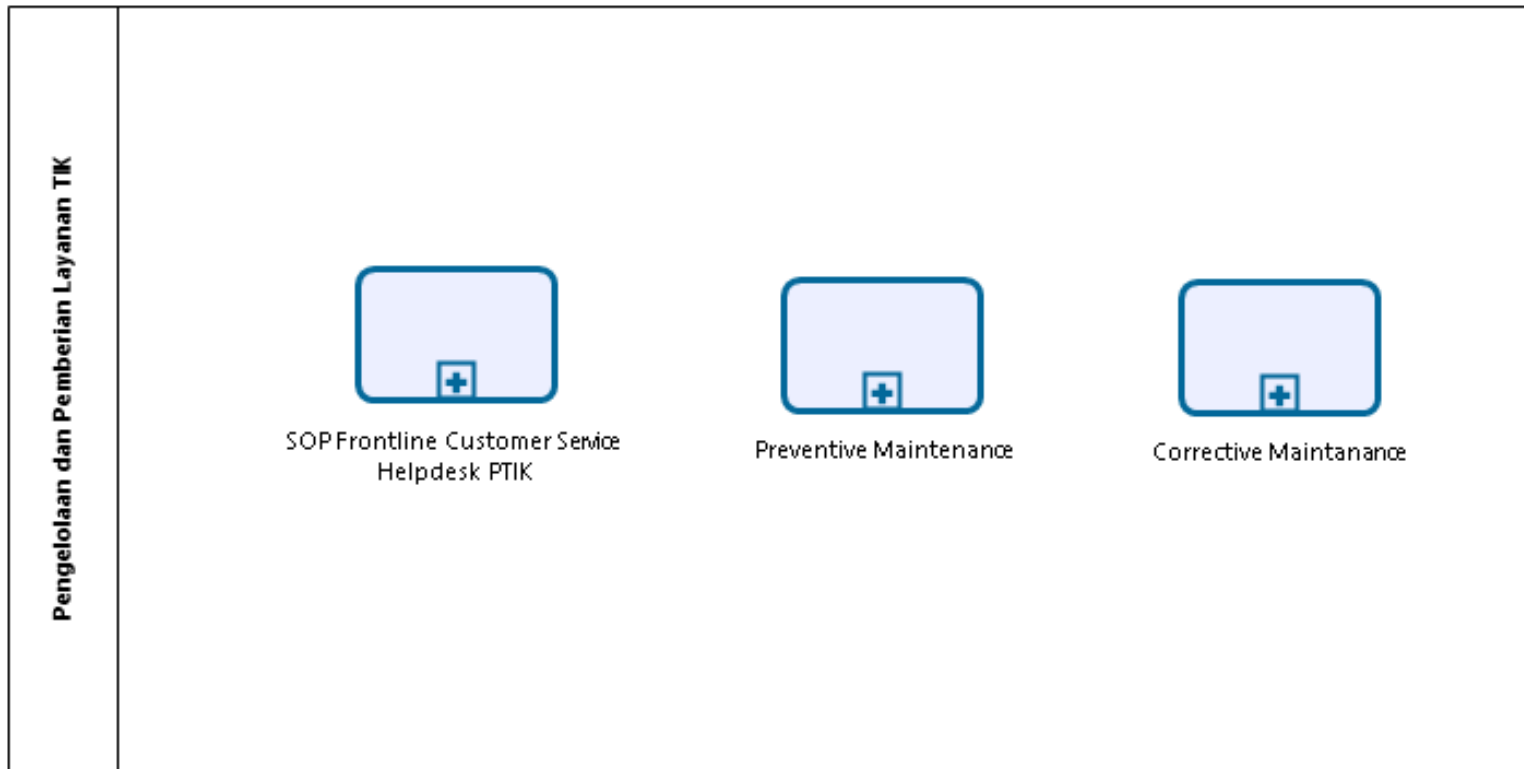



### 33 L1 - Layanan Bahasa

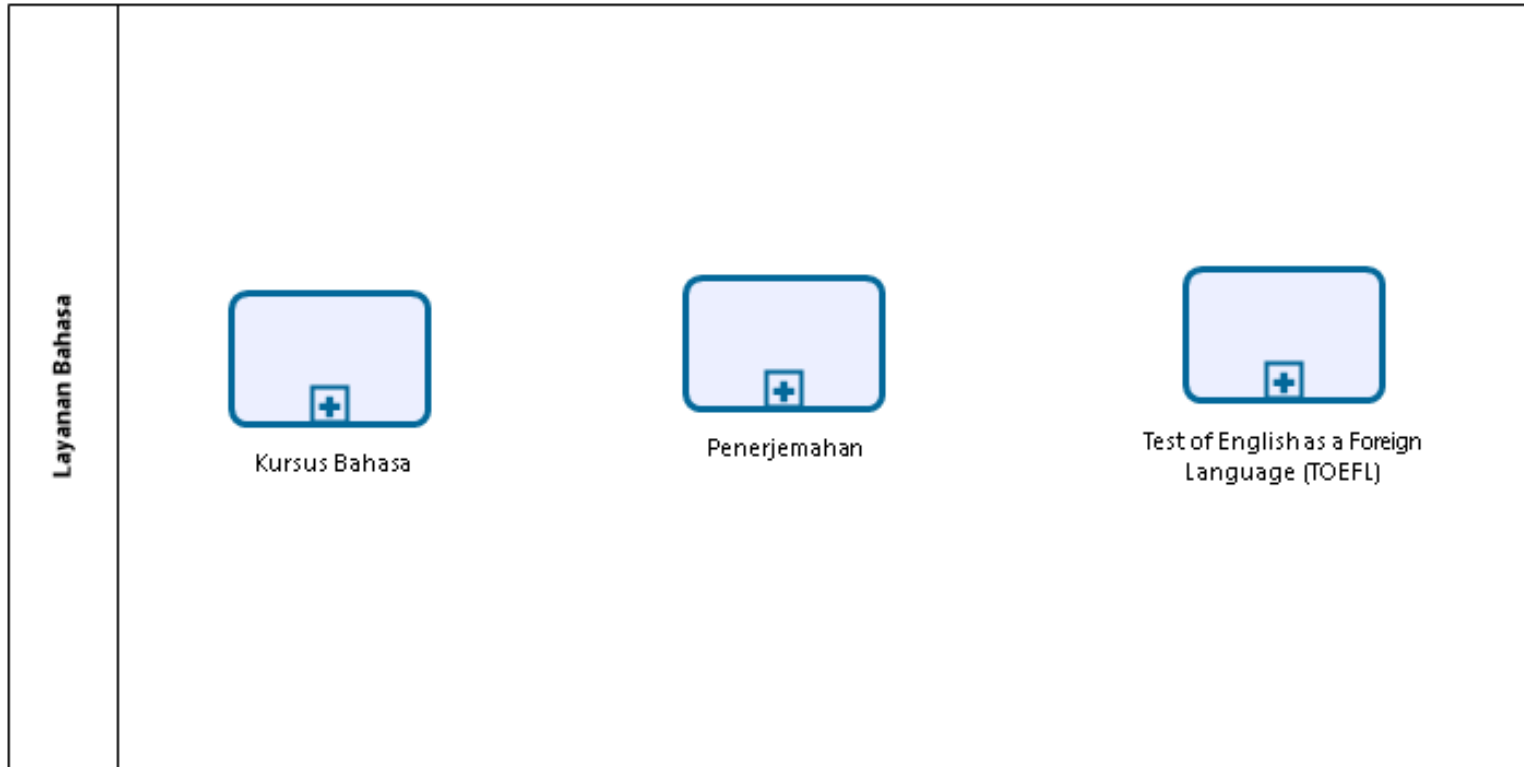



## 34 L1 - Layanan Laboratorium Terpadu

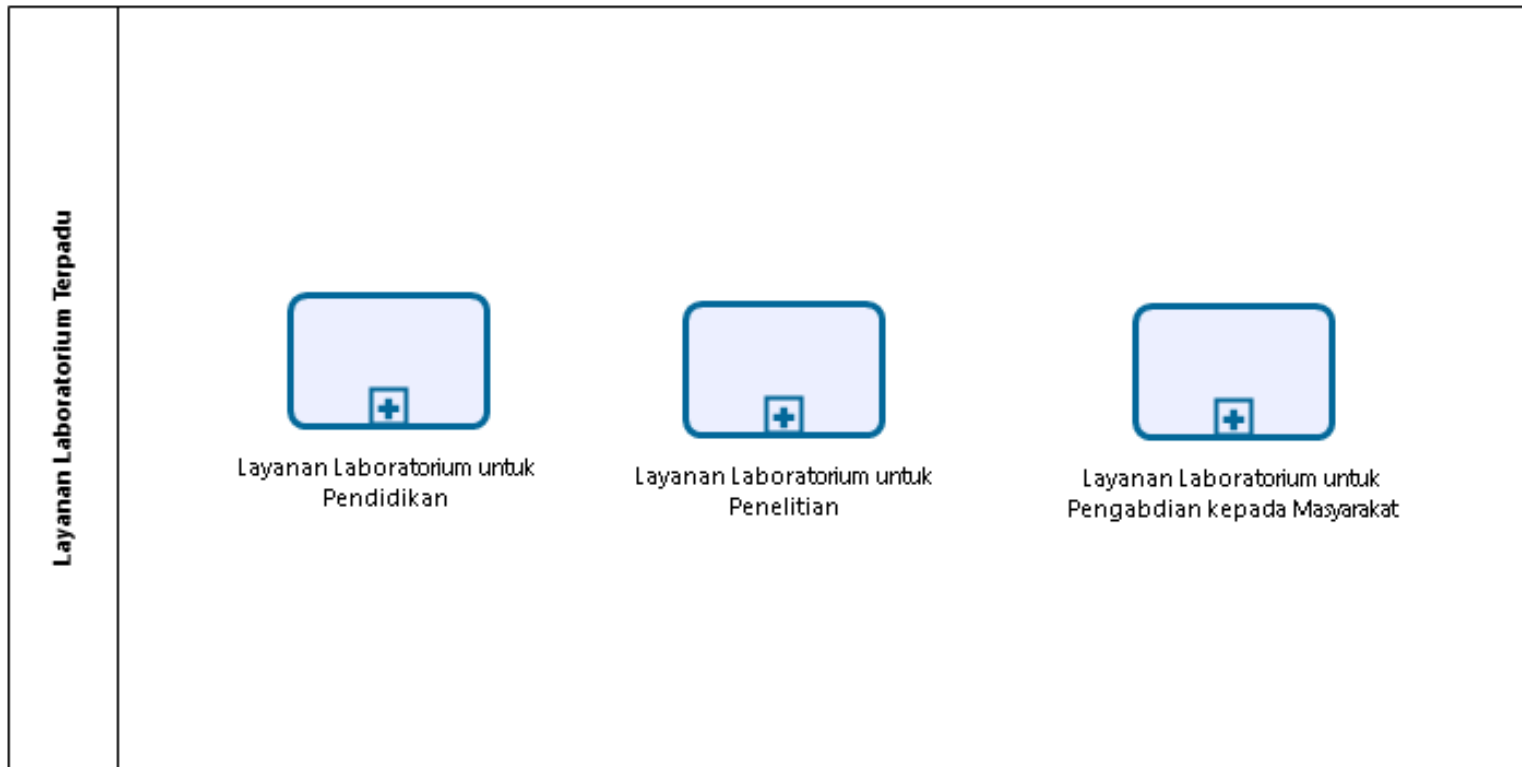



## 35 L1 - Layanan Pengawasan Internal

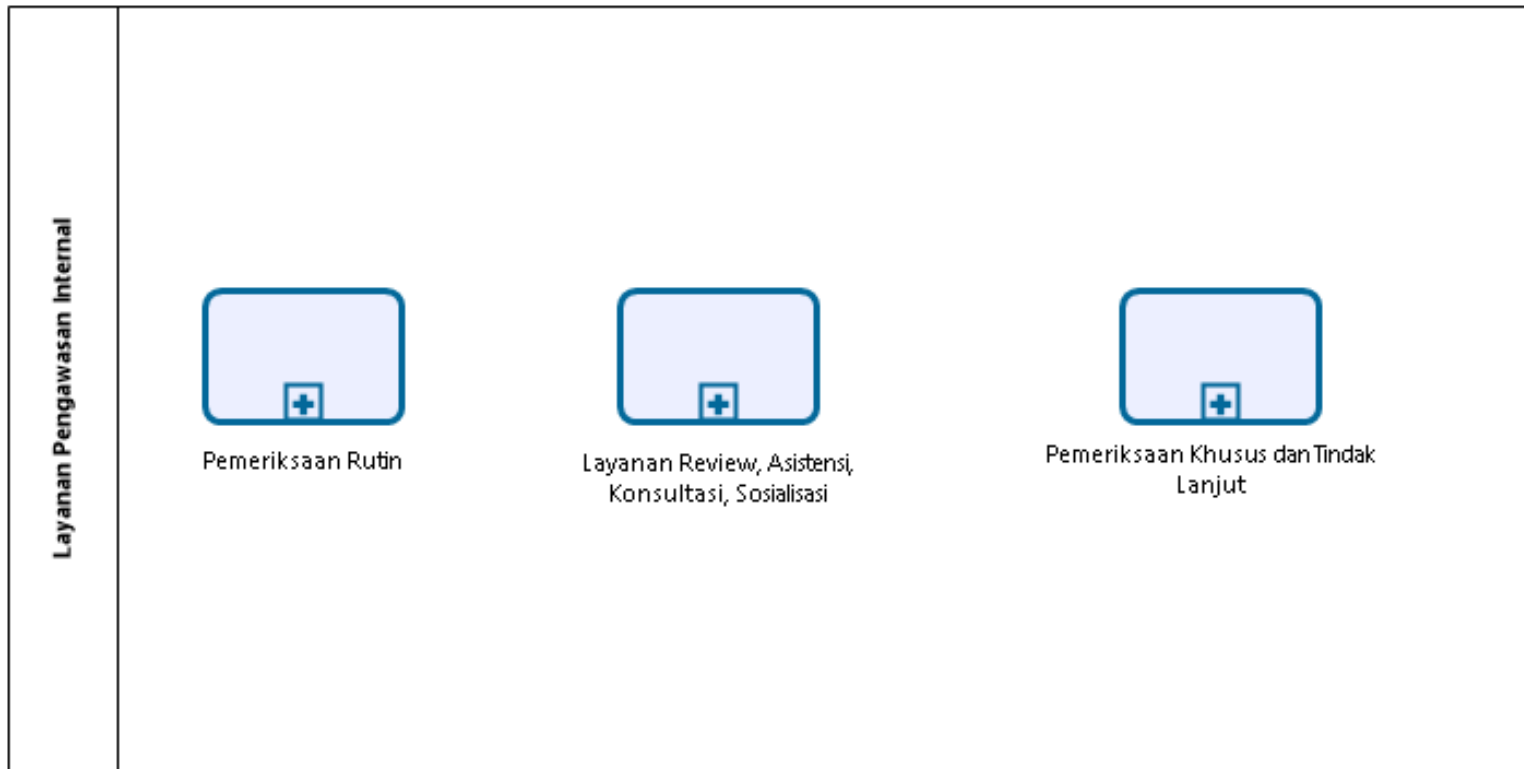



### 36 SOP Persetujuan Cuti

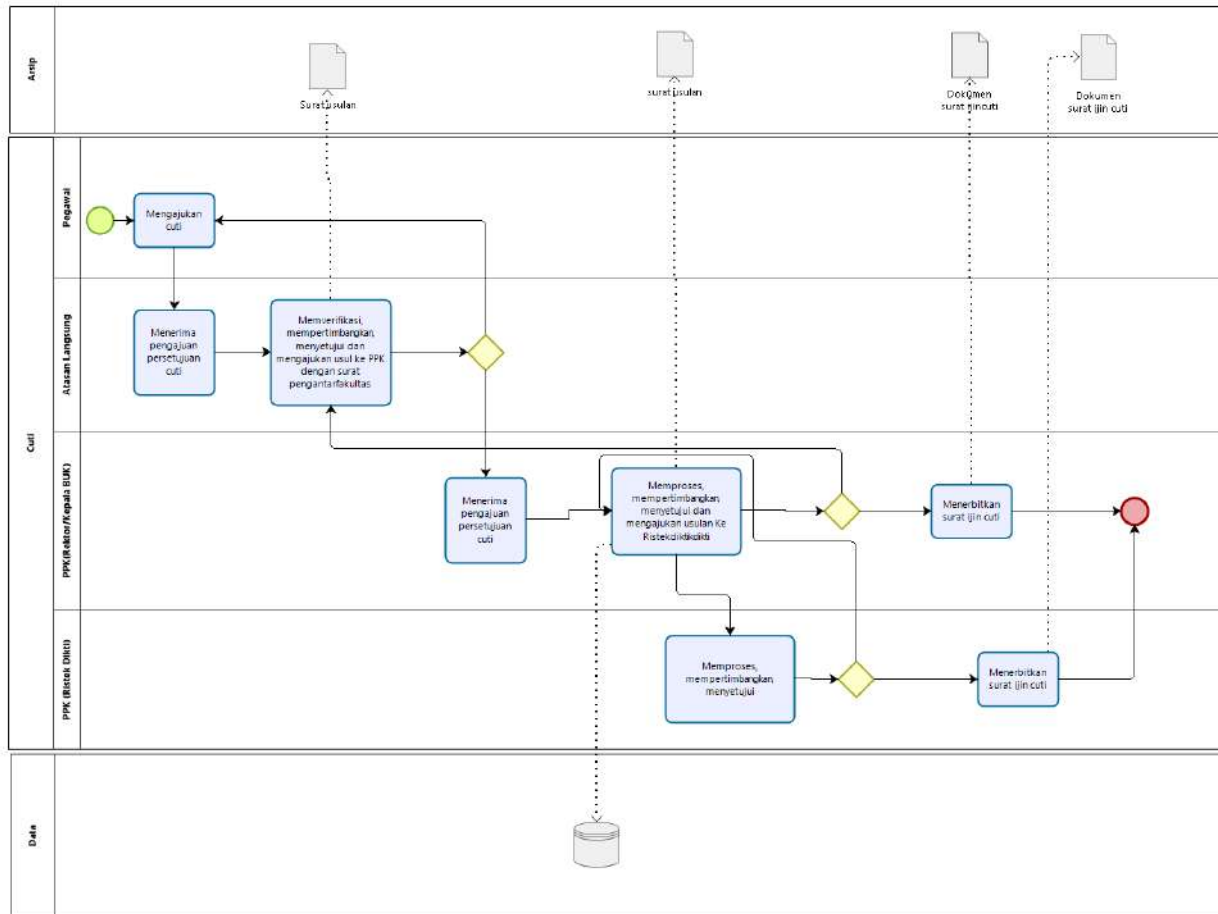



### 37 SOP Akreditasi

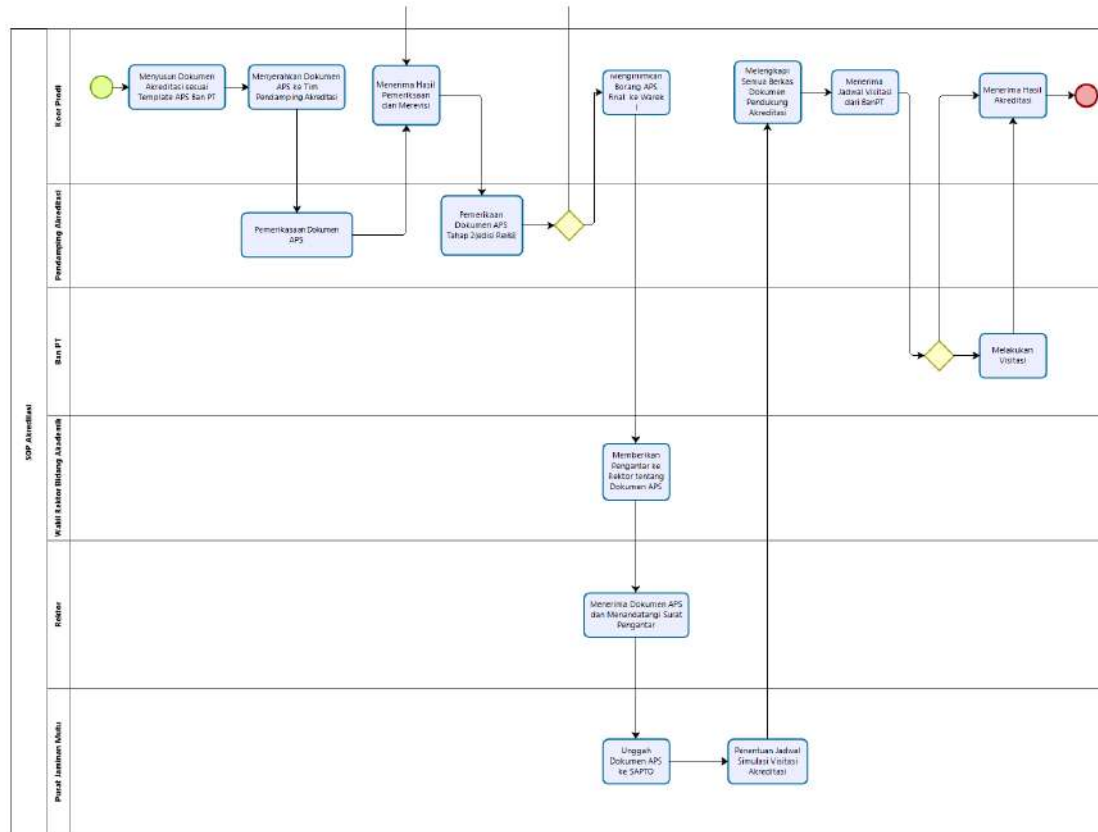





### 38 SOP Aktif Kembali Dari Cuti Kuliah

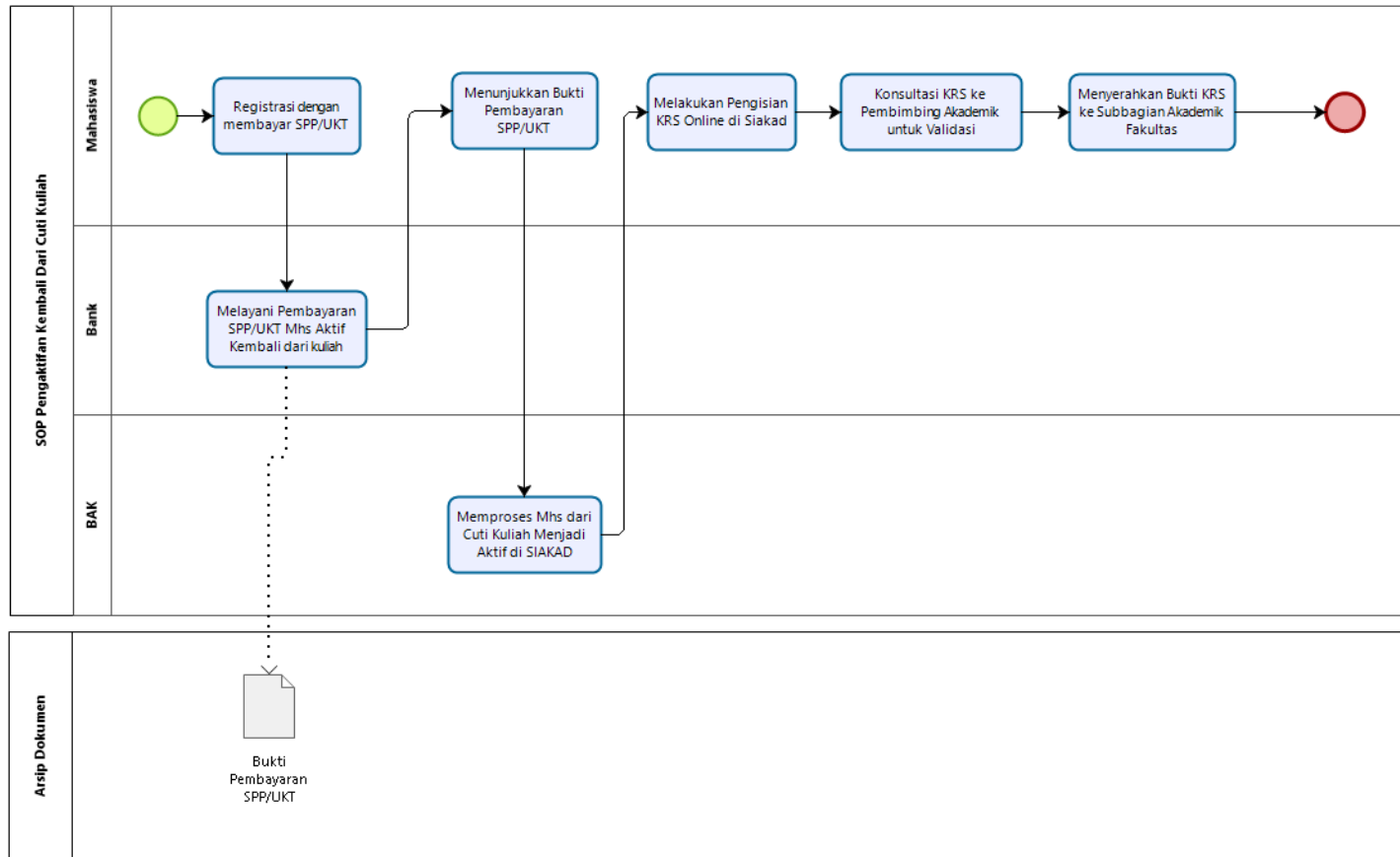



### 39 SOP Aktifasi Blokir KTA

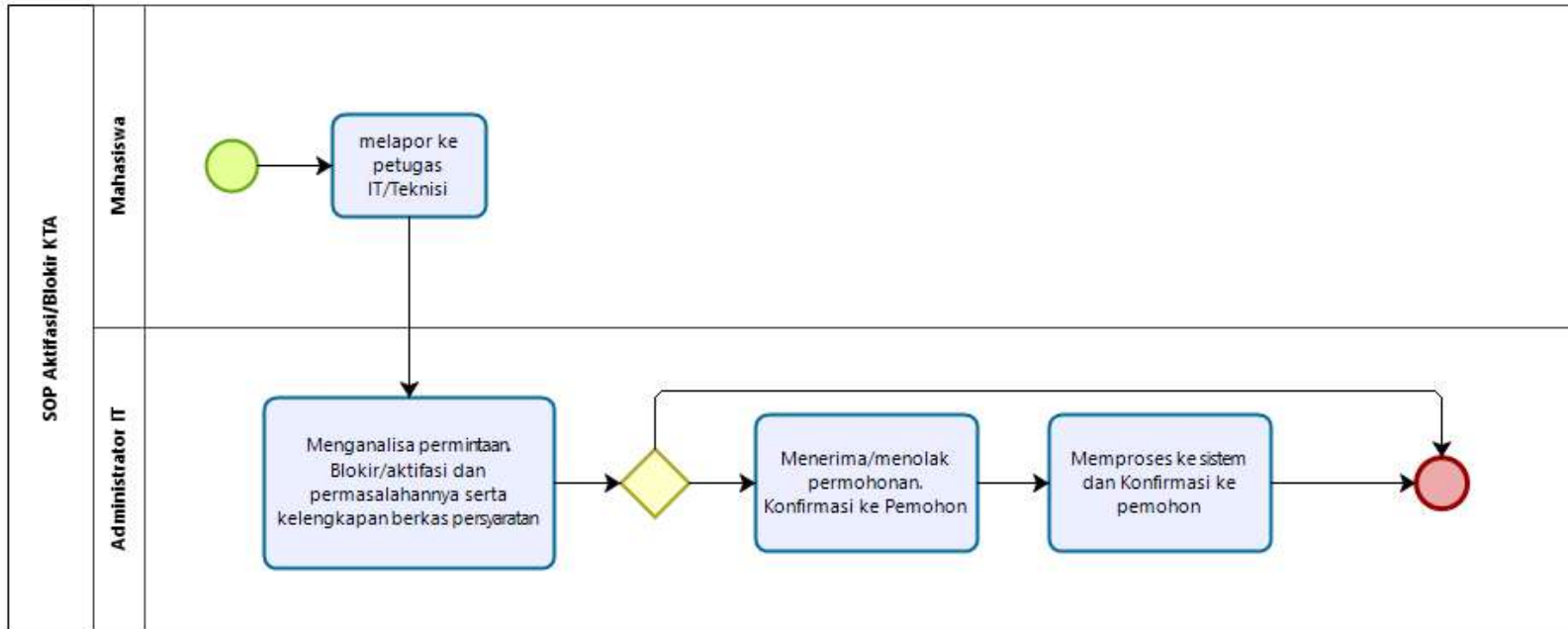



## 40 SOP Audit Internal

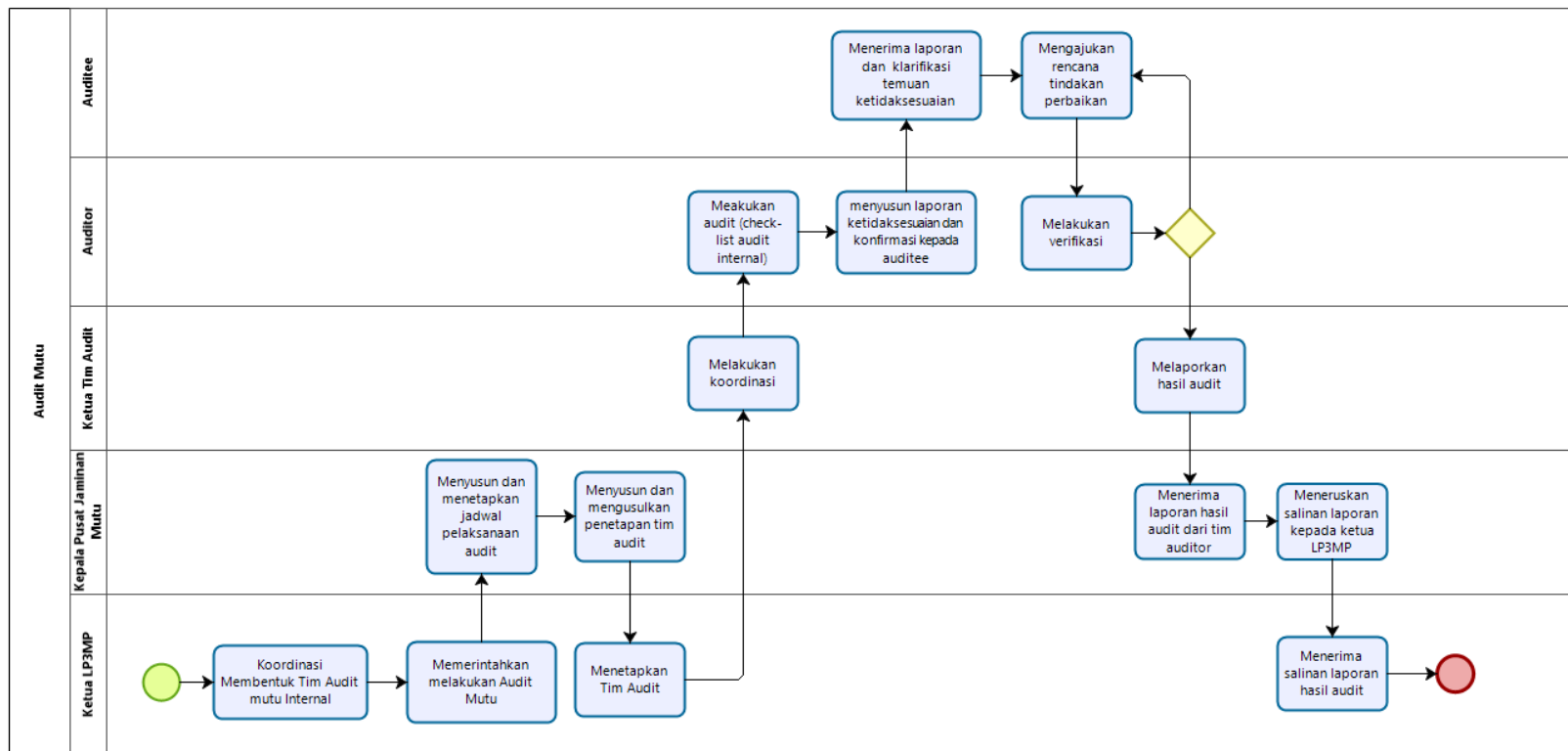



# 41 SOP Audit Mutu

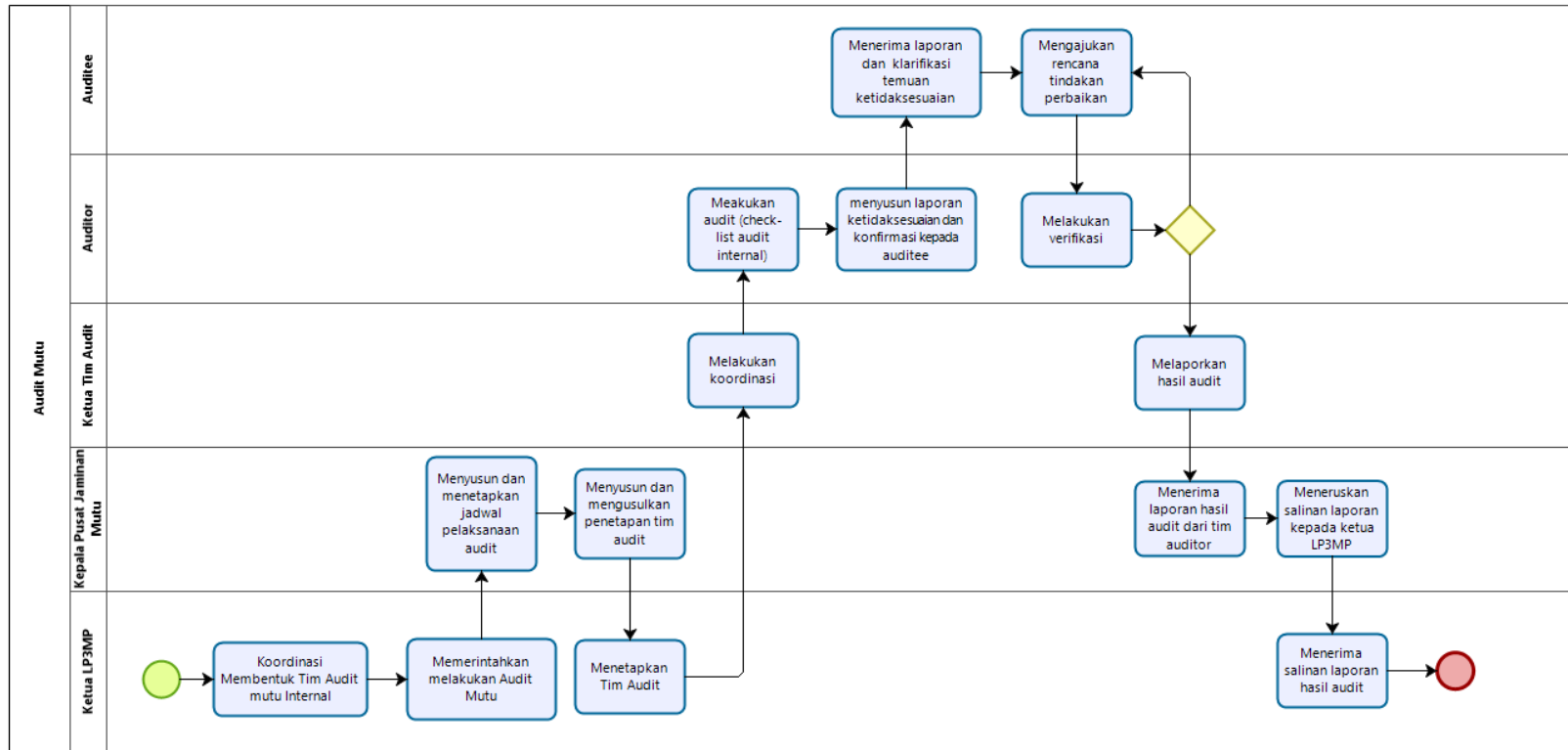



## 42 SOP Bantuan Pelayanan Pendaftaran dan Registrasi Jalur SNMPTN, SBMPTN, Dan Mandiri

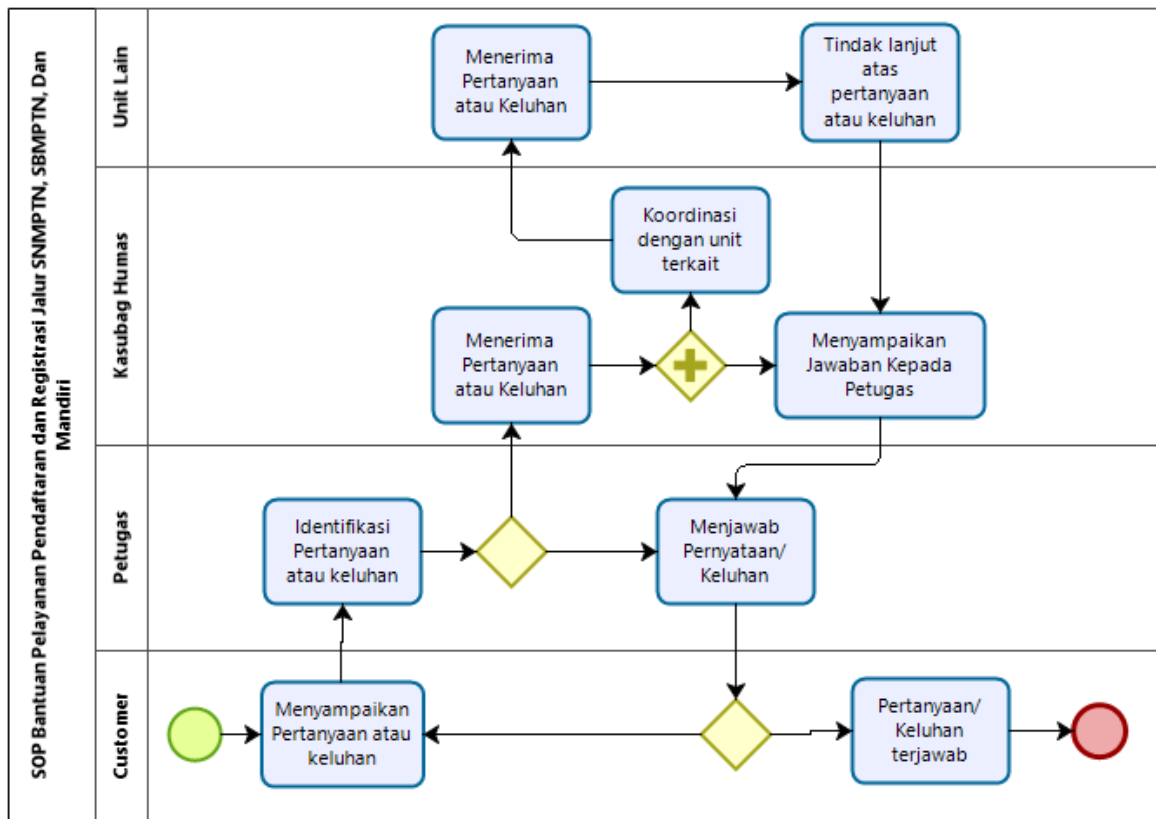



### 43 SOP Bebas Pustaka

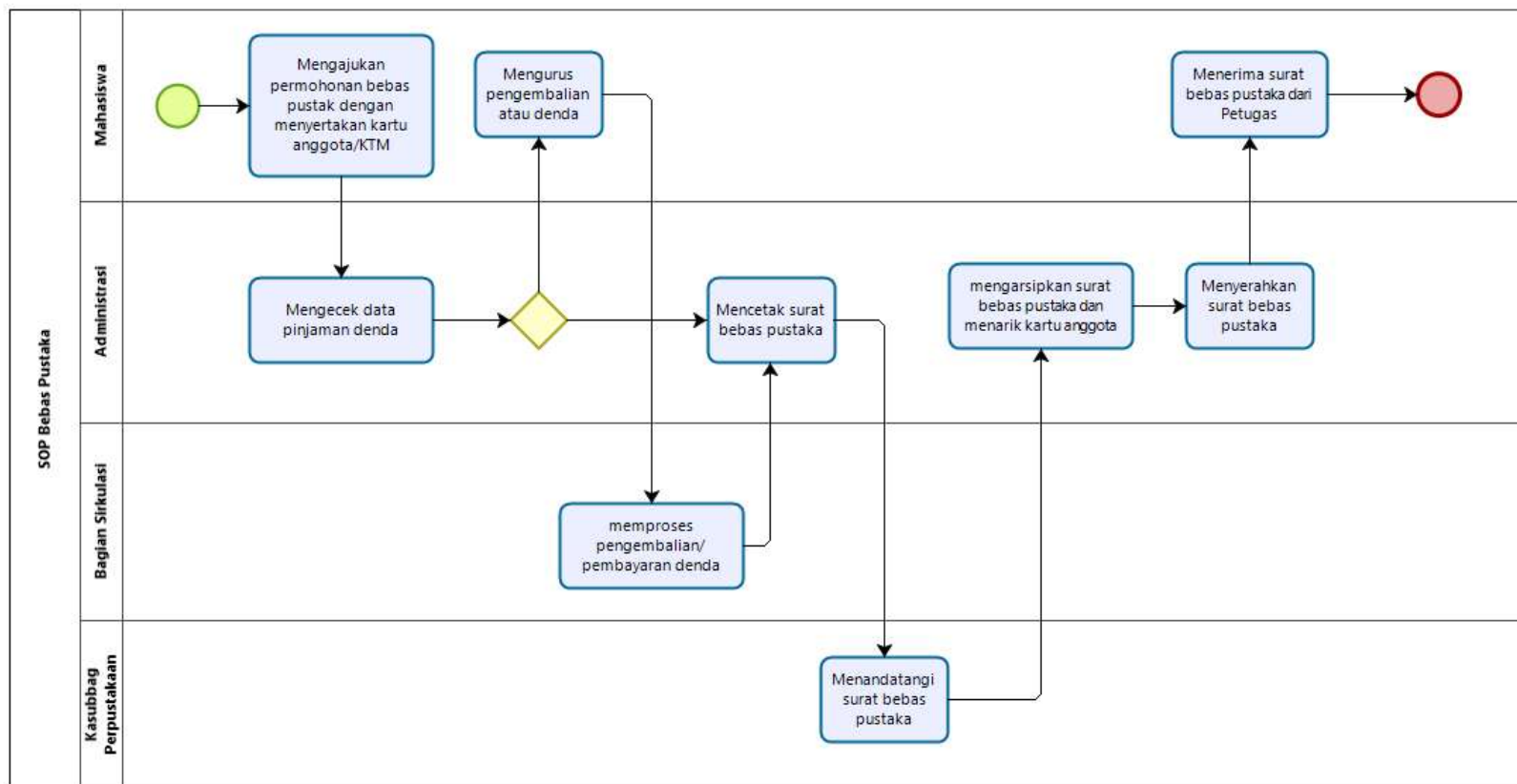



## 44 SOP Berhenti Studi Sementara (BSS)

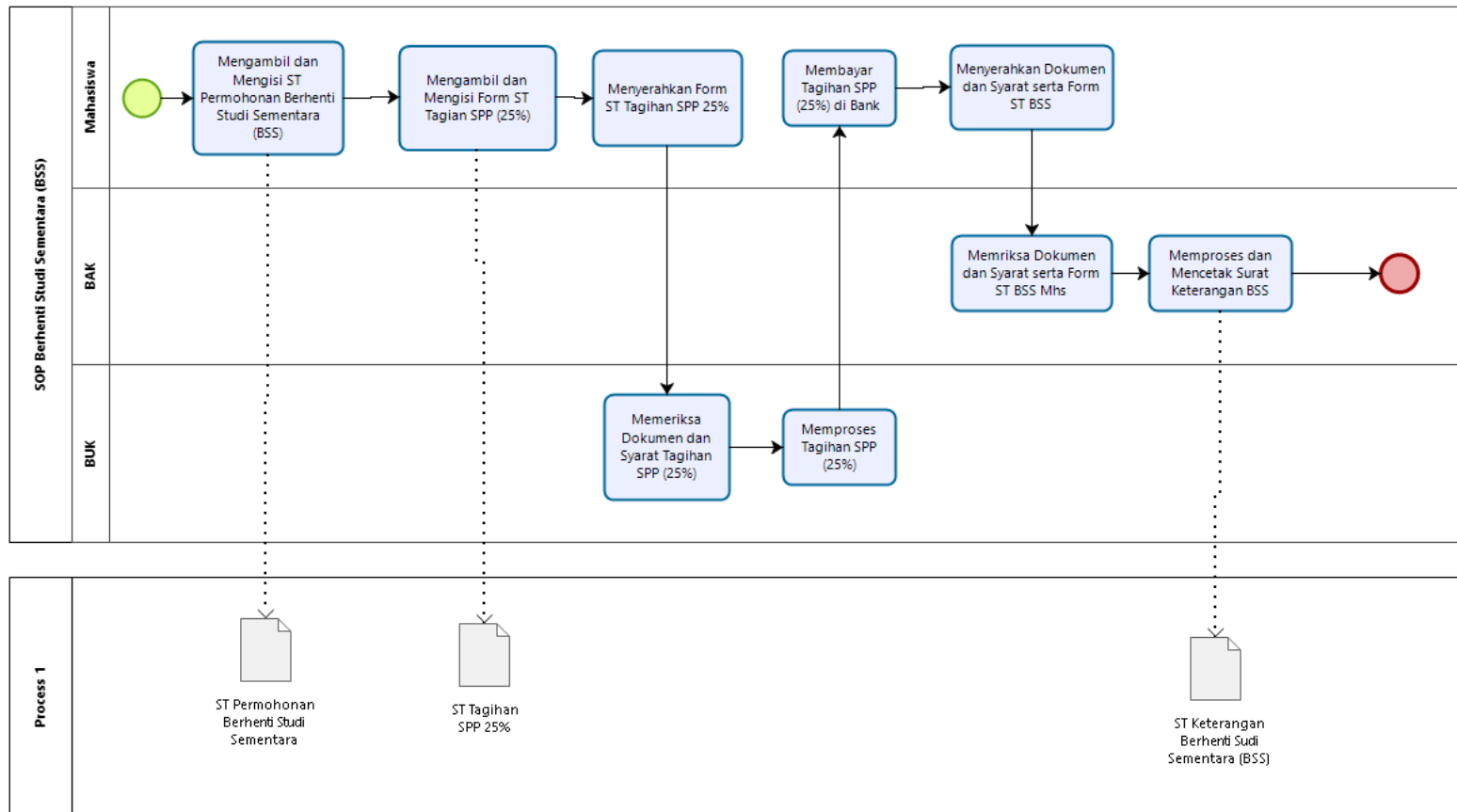



## 45 SOP Cetak Salinan Pembayaran UKT

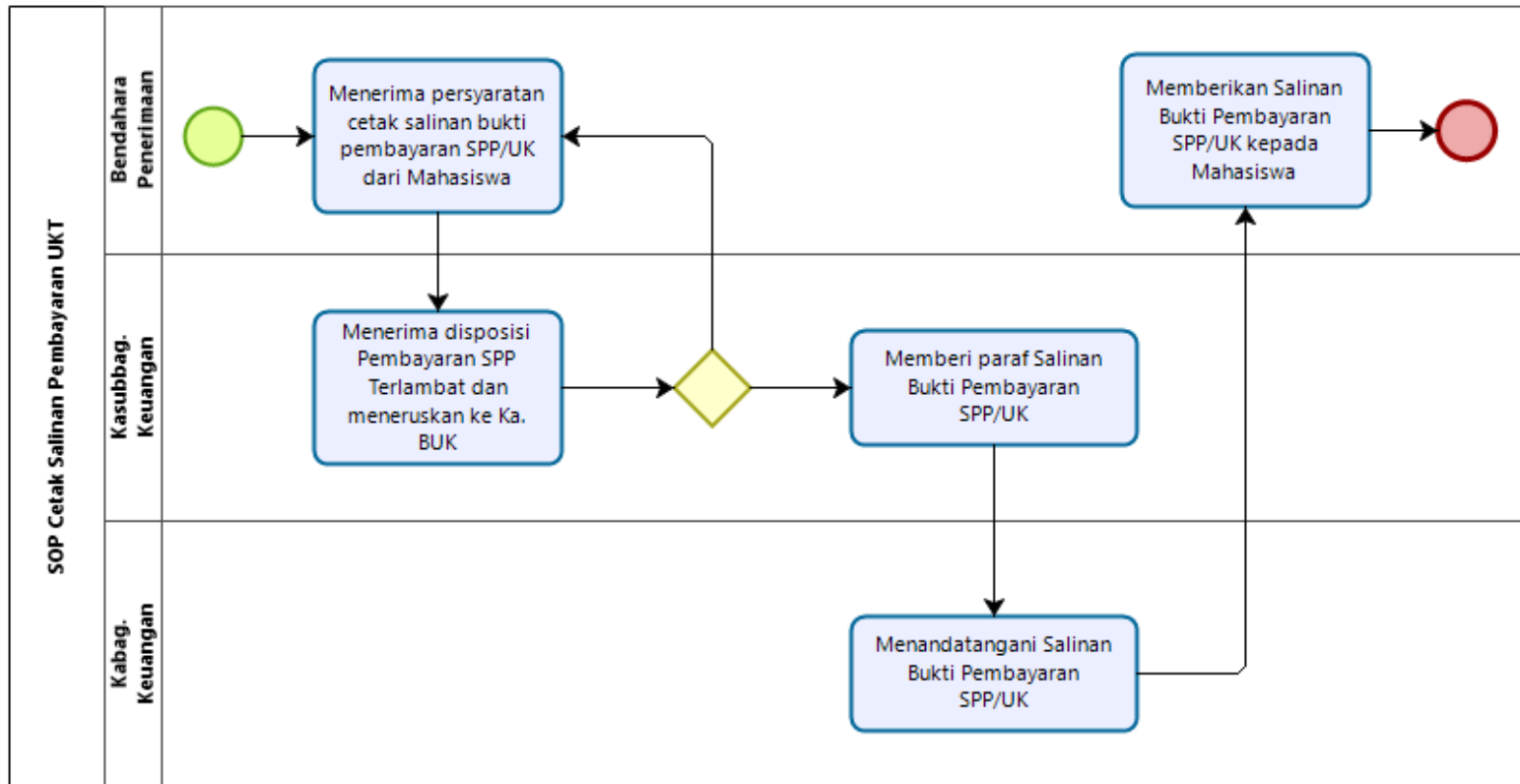





## 46 SOP Corrective Maintenance Perangkat

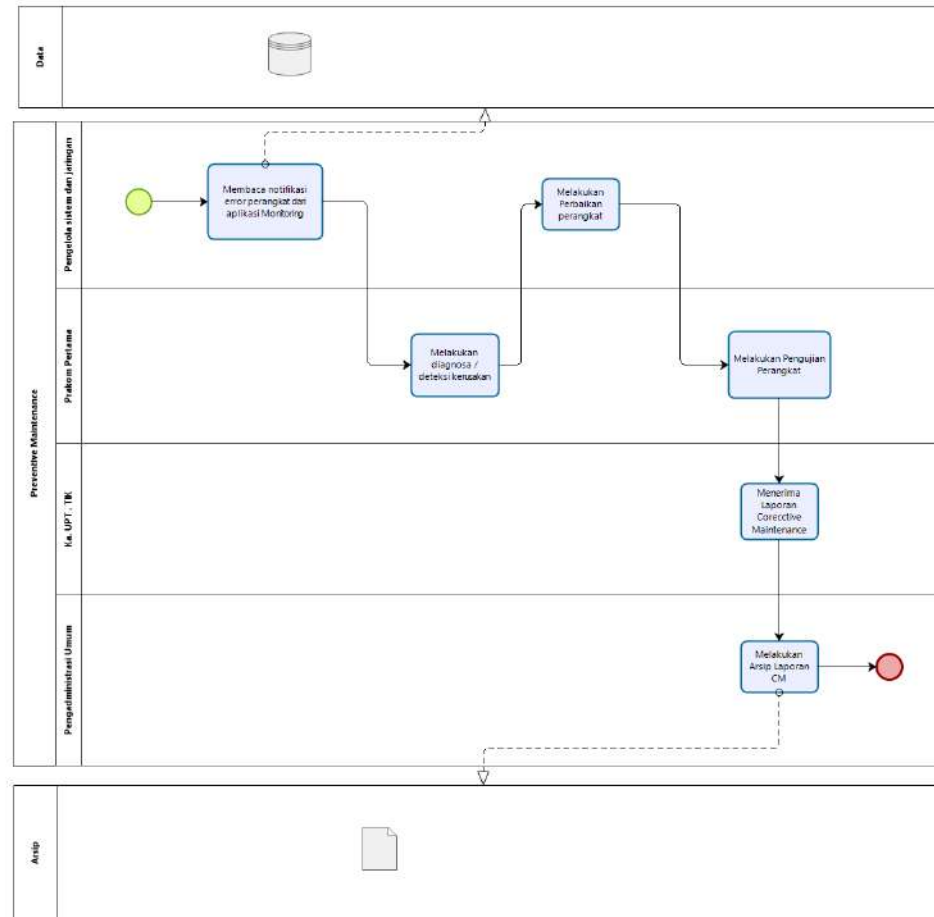



## 47 SOP Diseminasi Hasil Penelitian

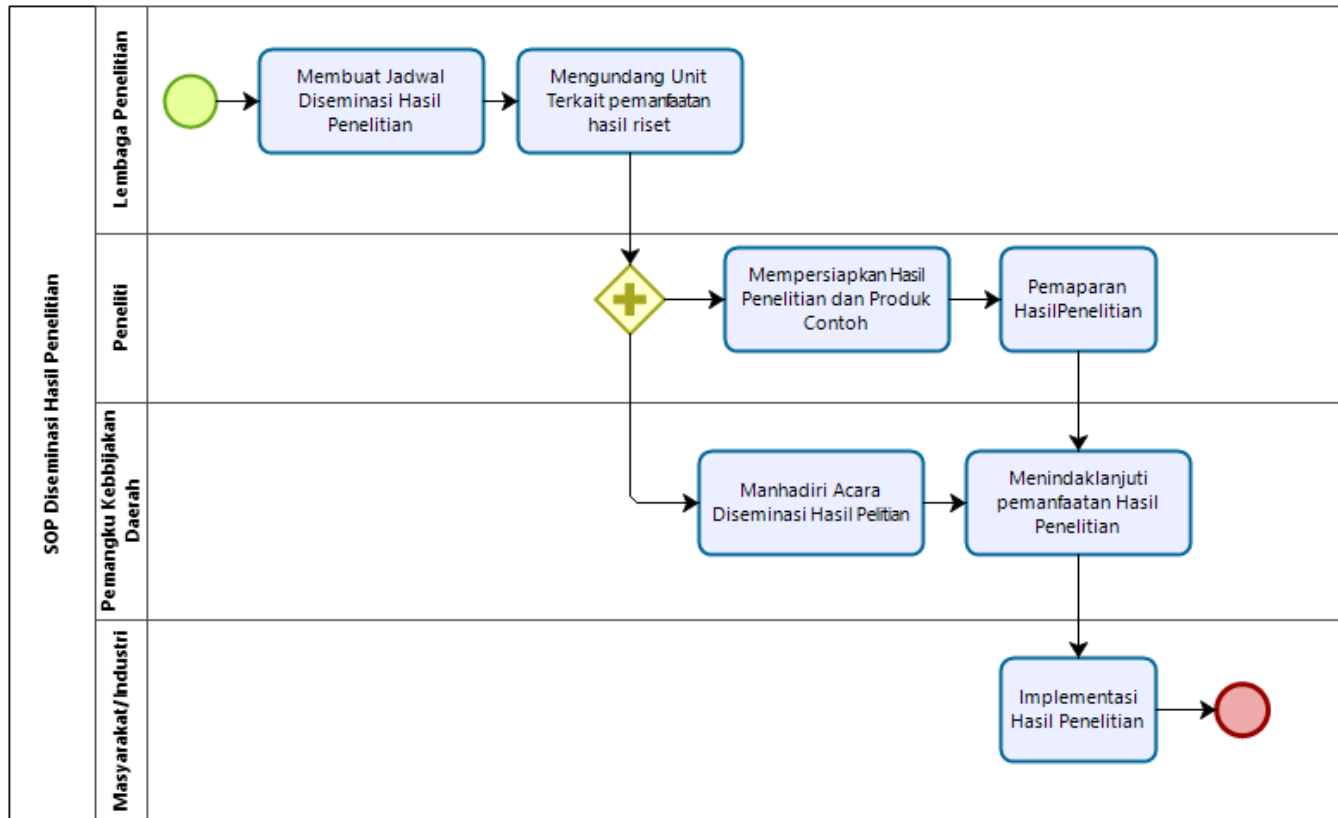



## 48 SOP engembangan Infrastruktur Backbone Fiber Optic

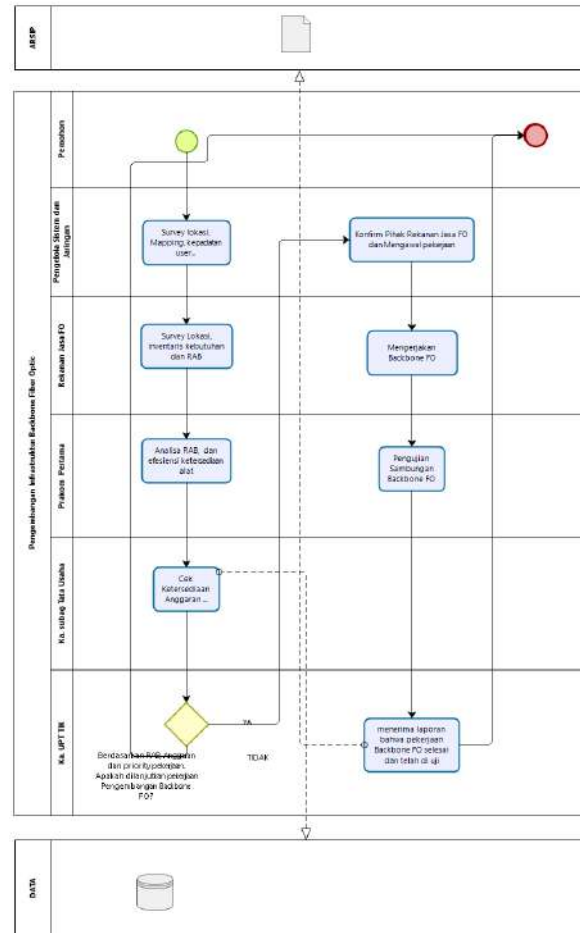



## 49 SOP Evaluasi dan Penilaian Pelaksanaan Proses Pembelajaran

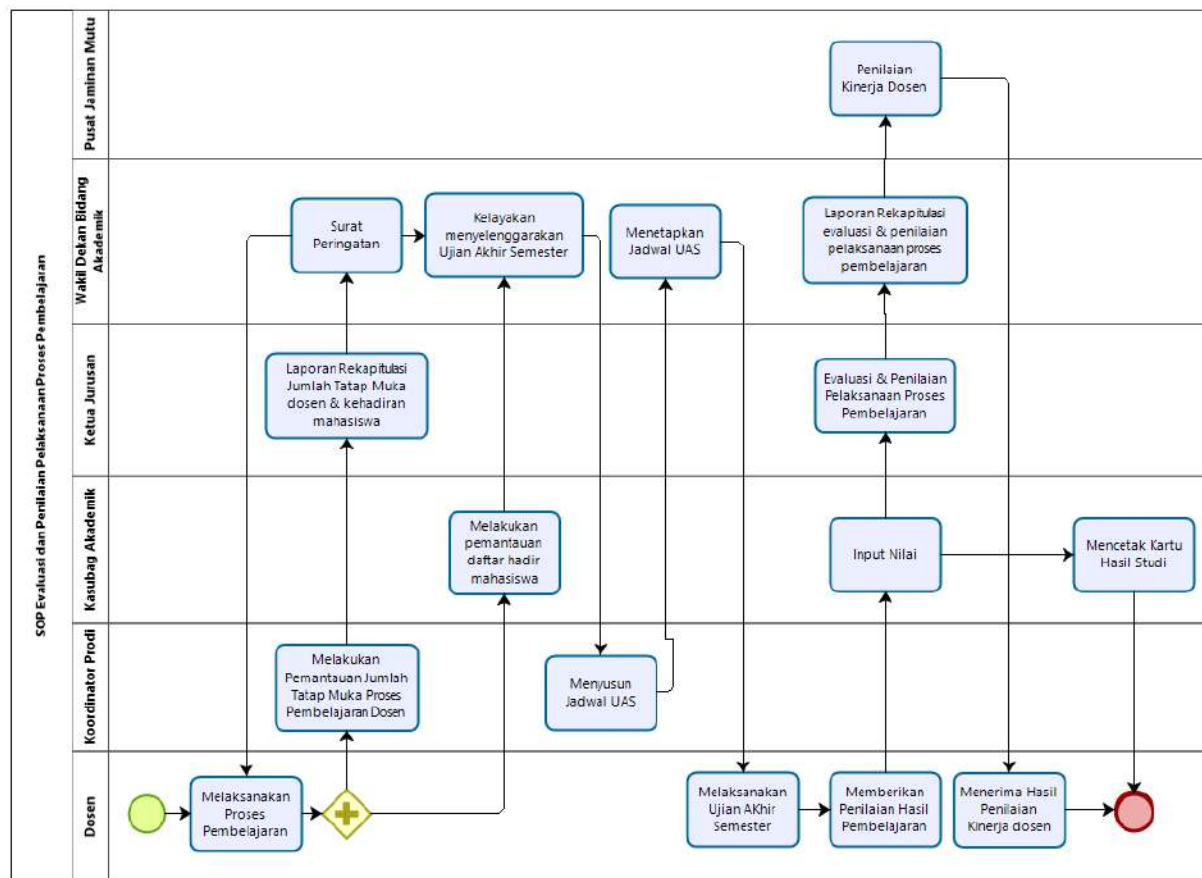



## 50 SOP Evaluasi Hasil Belajar Mengajar

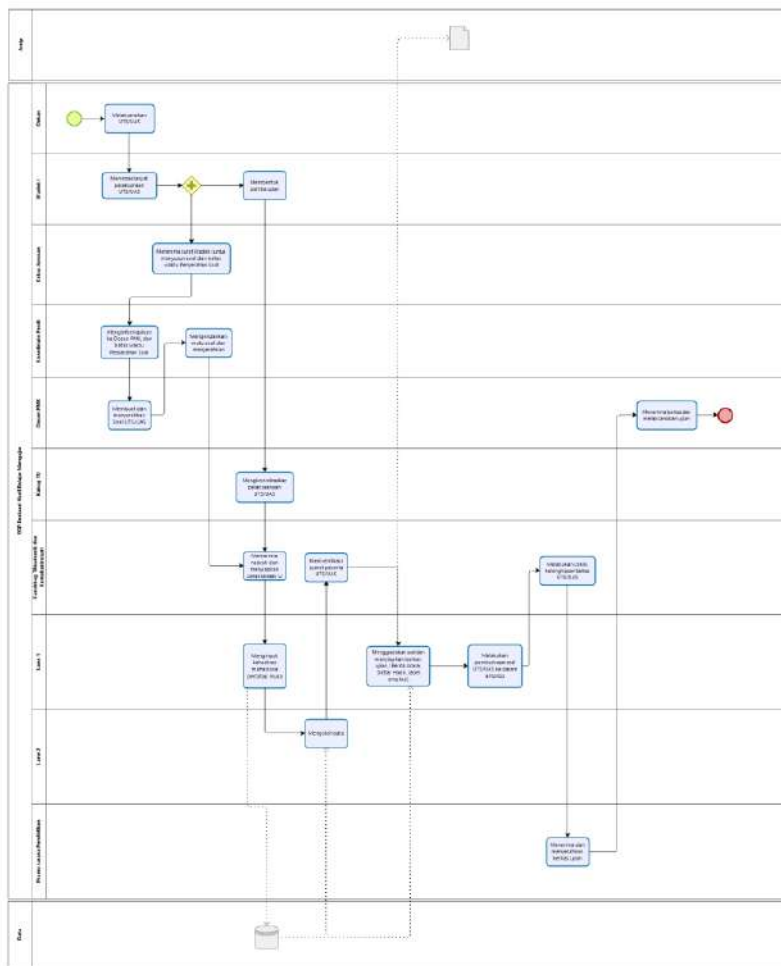



# 51 SOP Frontline Customer Service Helpdesk PTIK

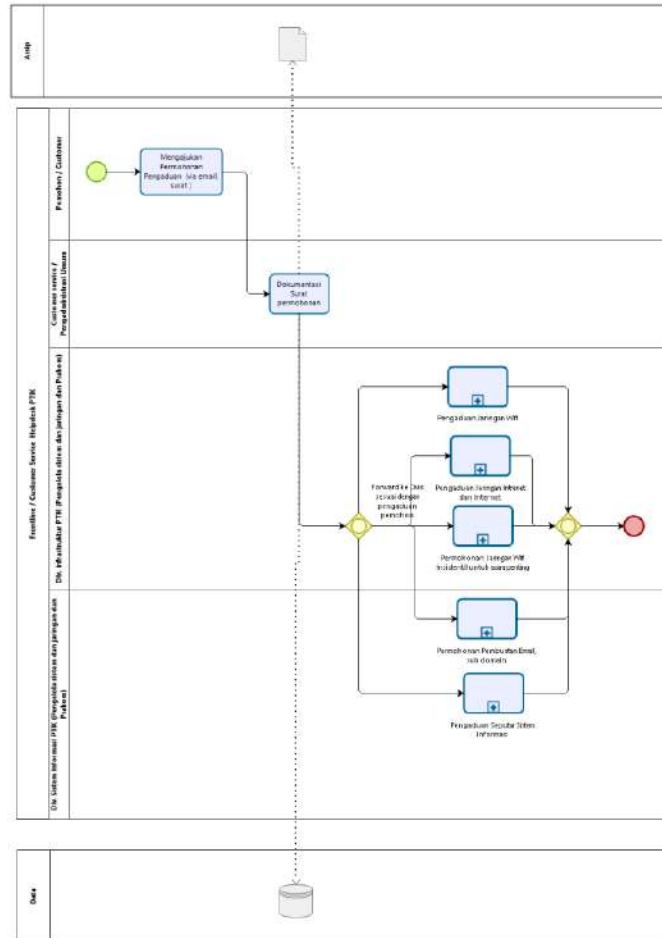



## 52 SOP Her Registrasi Mahasiswa

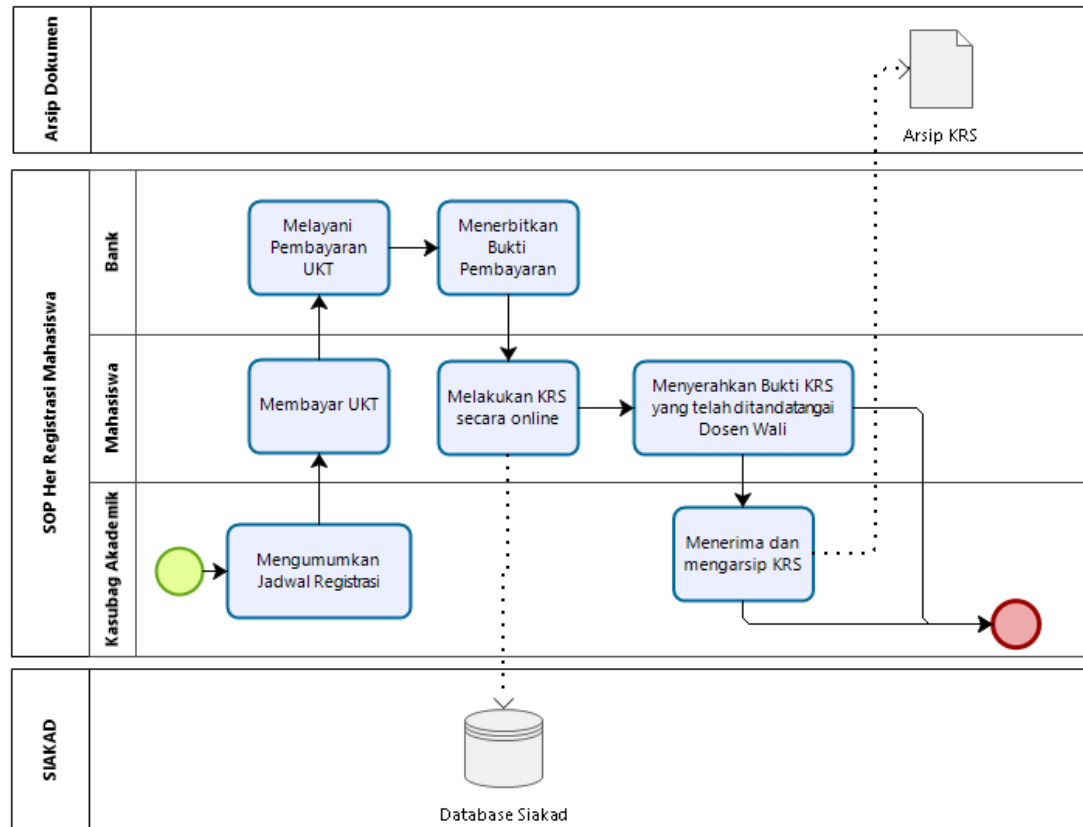



## 53 SOP Kartu Tamu

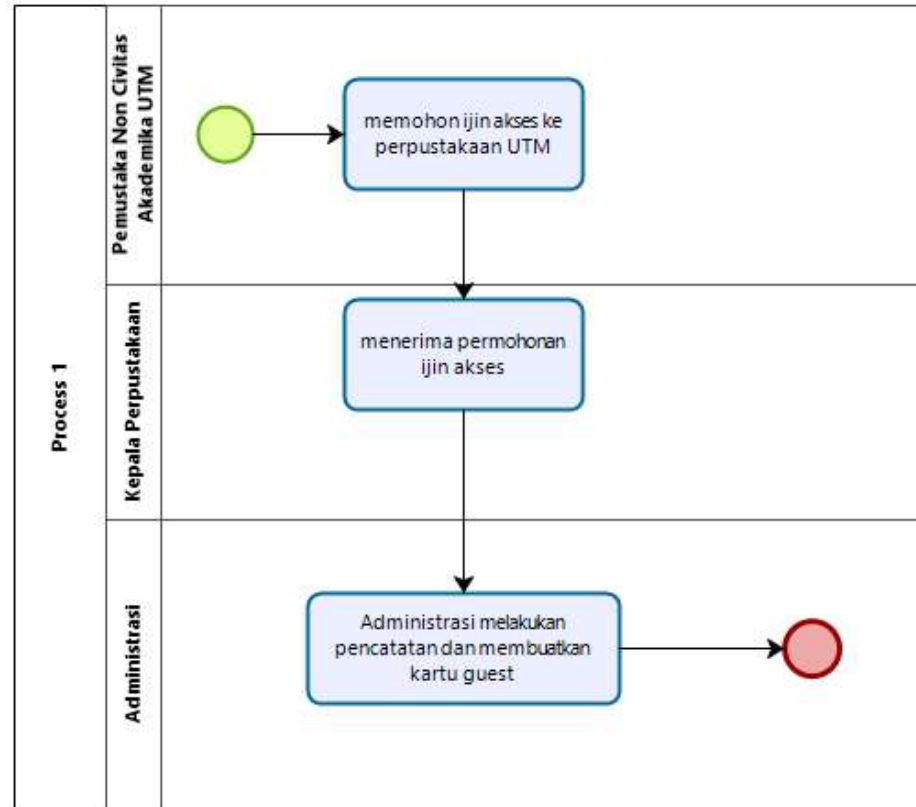





## 54 SOP Kenaikan Gaji Berkala

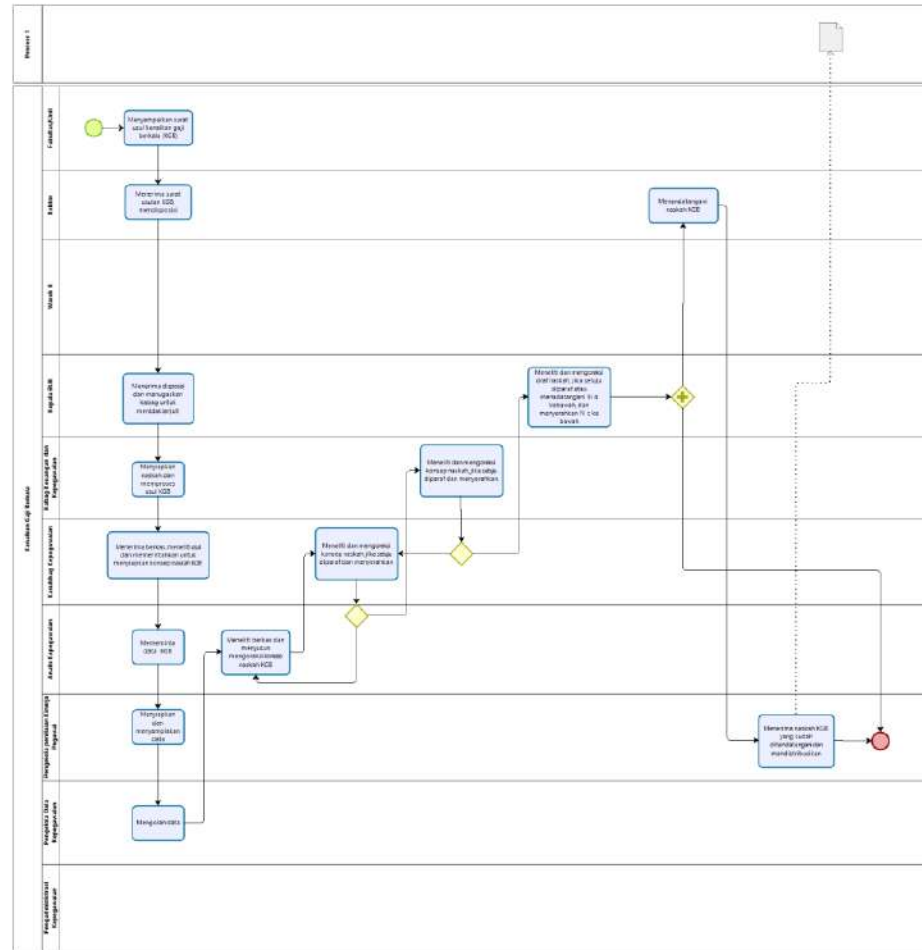





## 56 SOP Keprotokolan

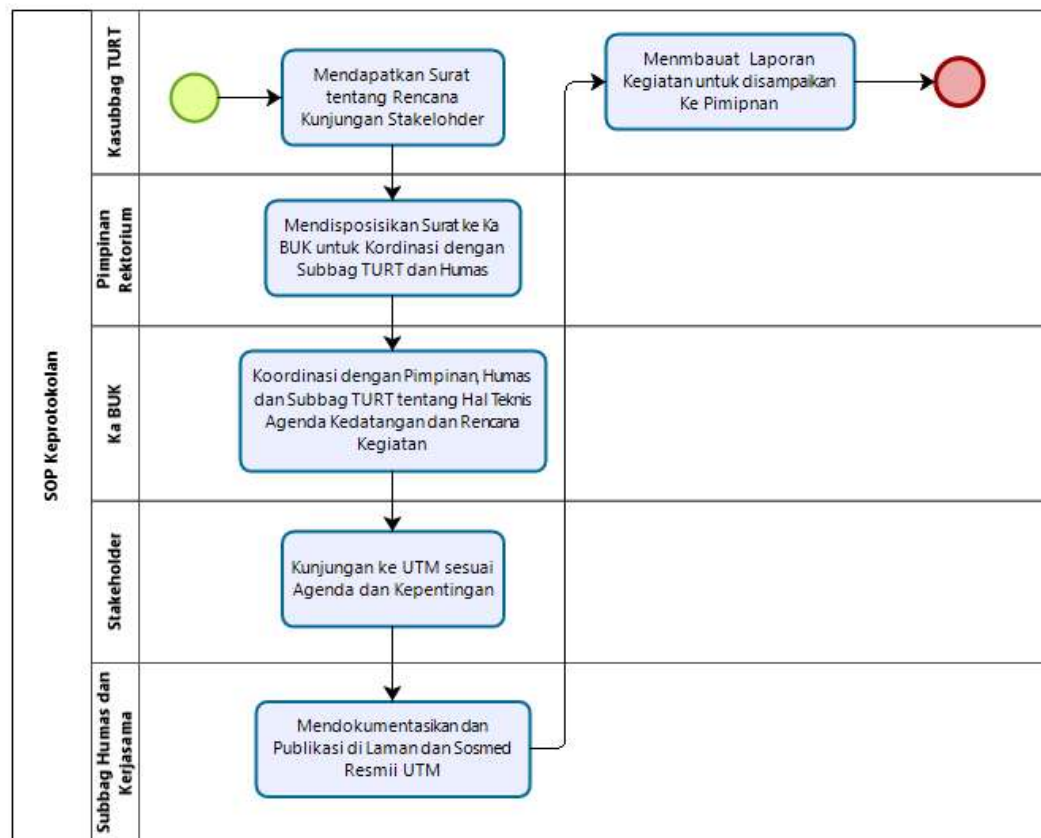



## 57 SOP Koleksi Dokumen Penjaminan Mutu

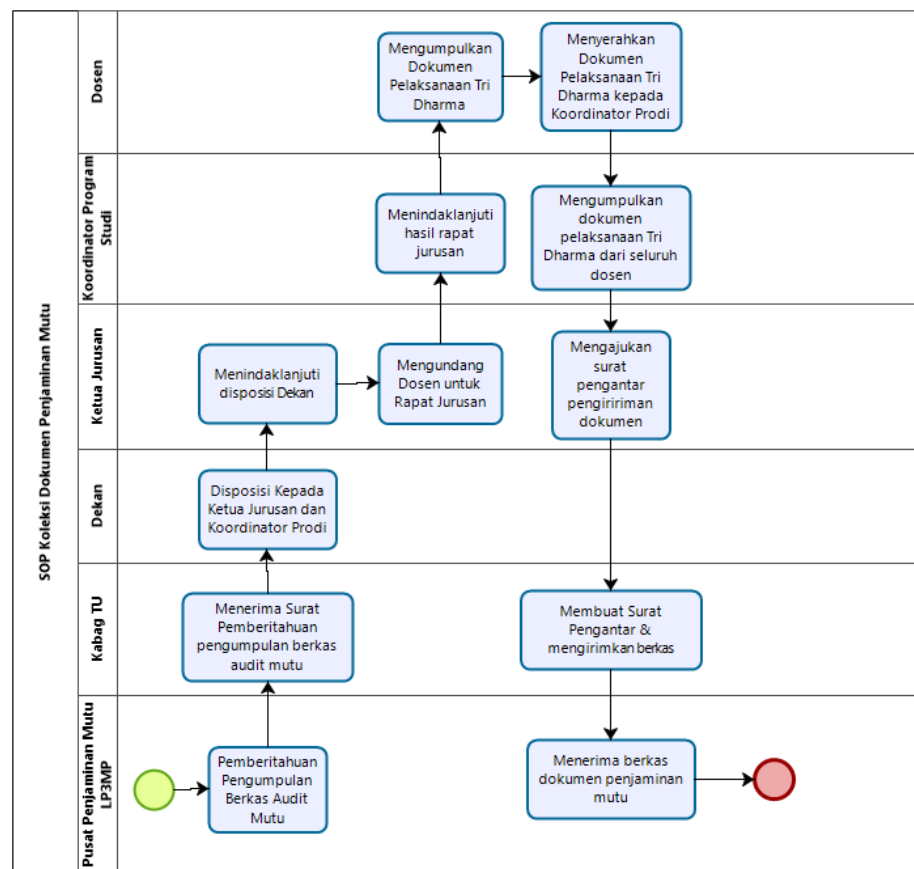



## 58 SOP Kuliah Tamu

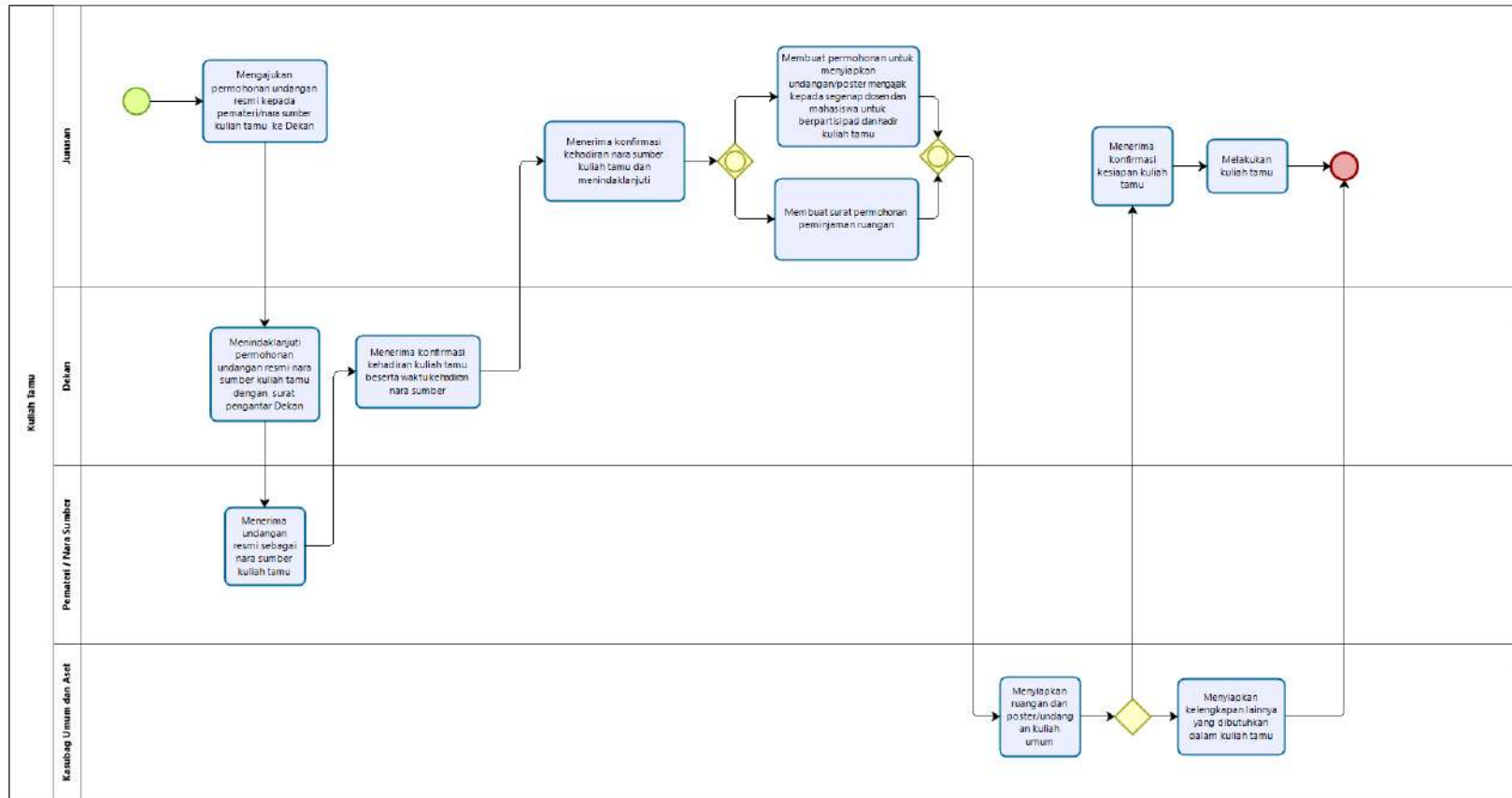



## 59 SOP Kursus Bahasa

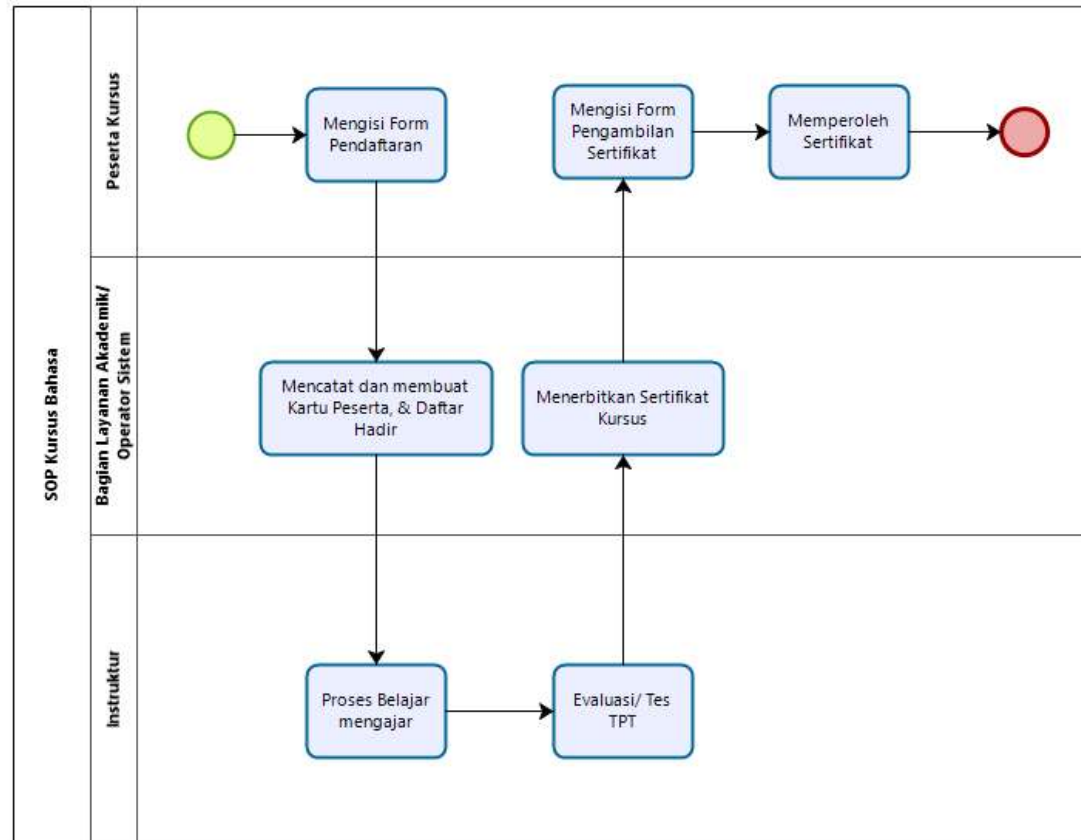



## 60 SOP Layanan Cetak KHS

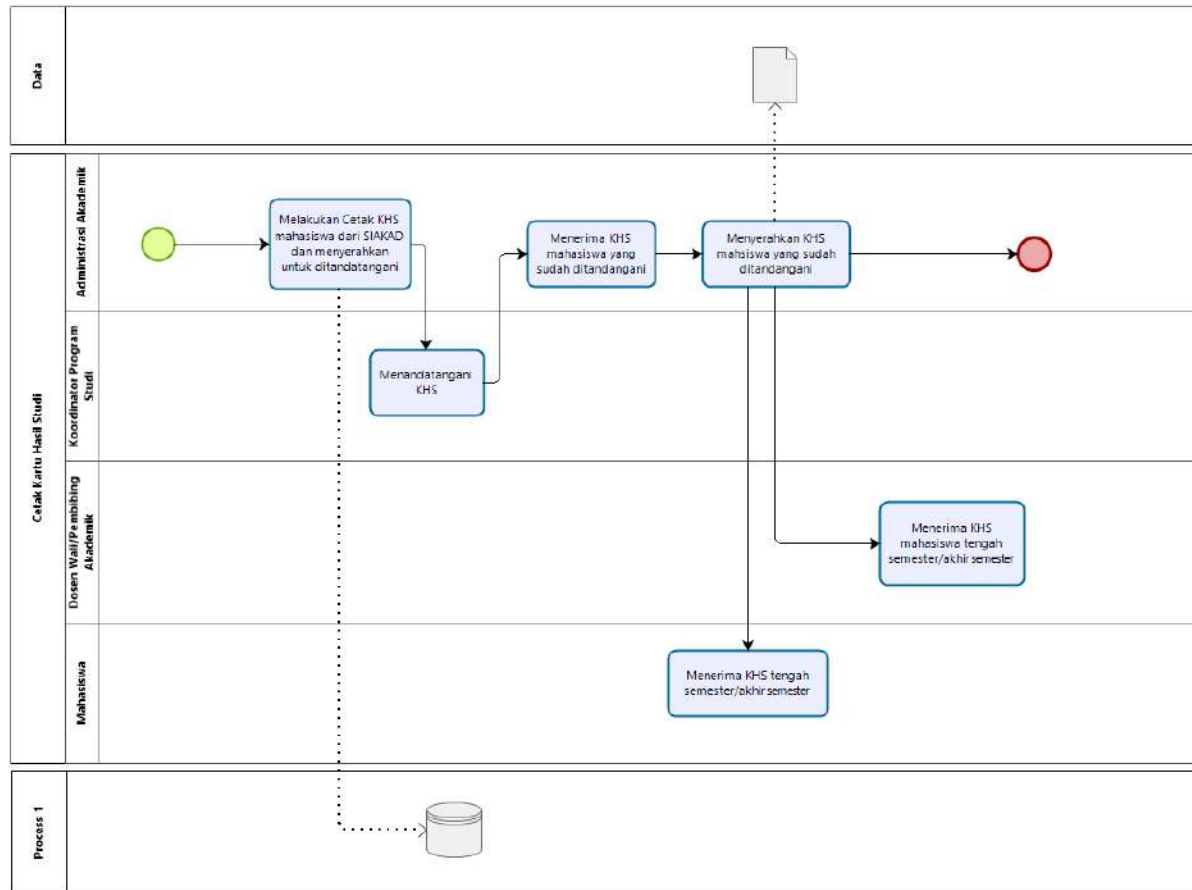



## 61 SOP Layanan Dispensasi Kegiatan

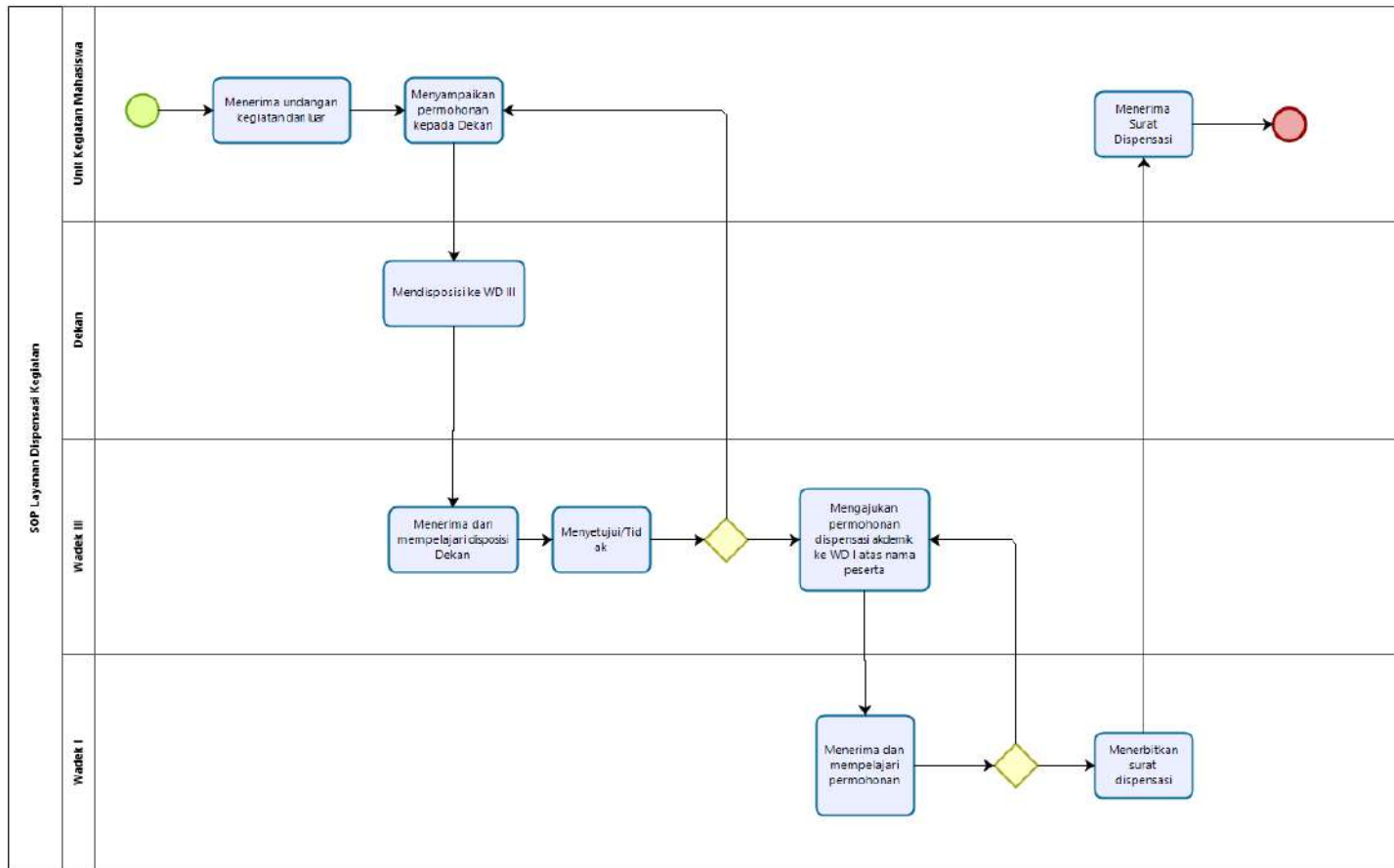





## 62 SOP Layanan E-Tugas Belajar

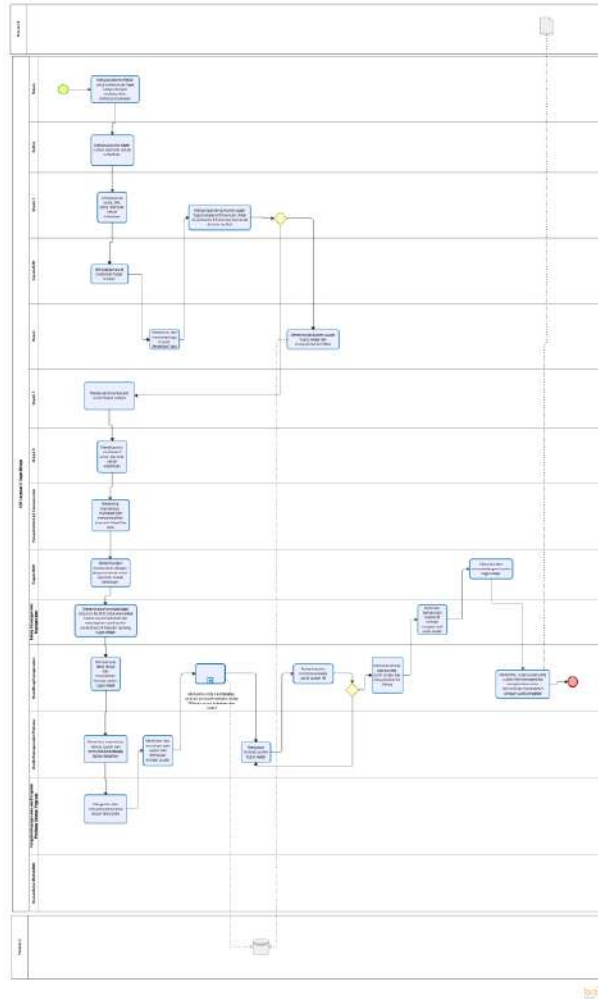



## 63 SOP Layanan Ijin Studi Lanjut

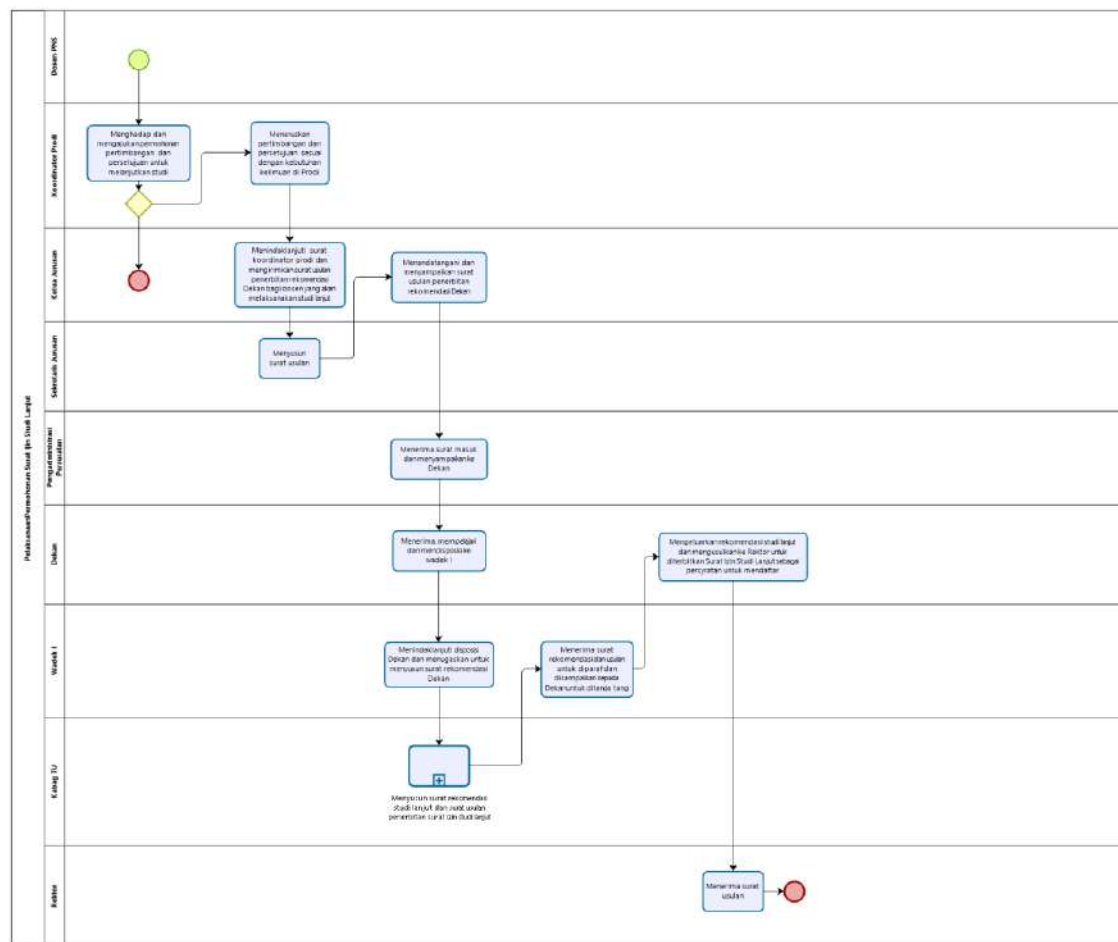



## 64 SOP Layanan Identifikasi dan verifikasi kerusakan

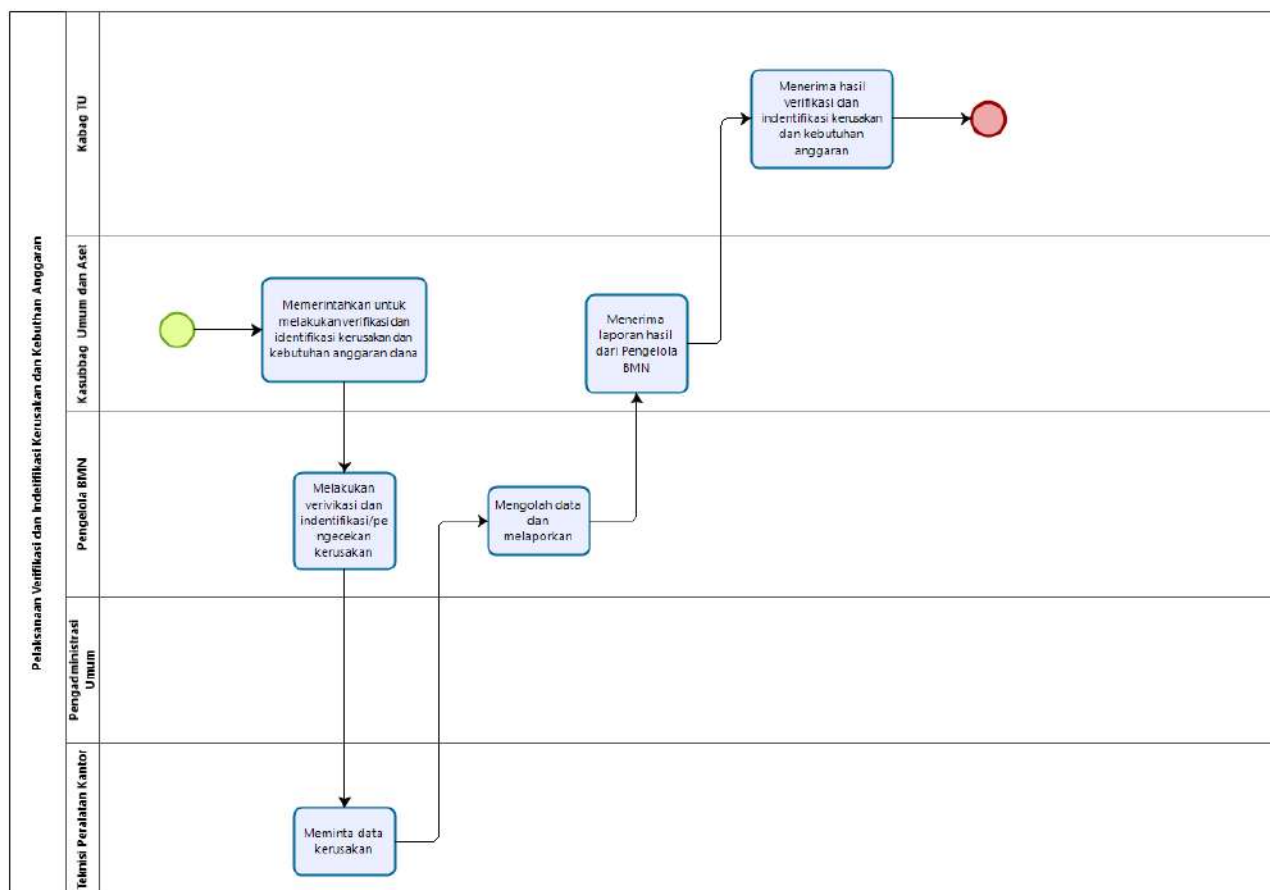



## 65 SOP Layanan Kenaikan Jabatan Akademik Dosen

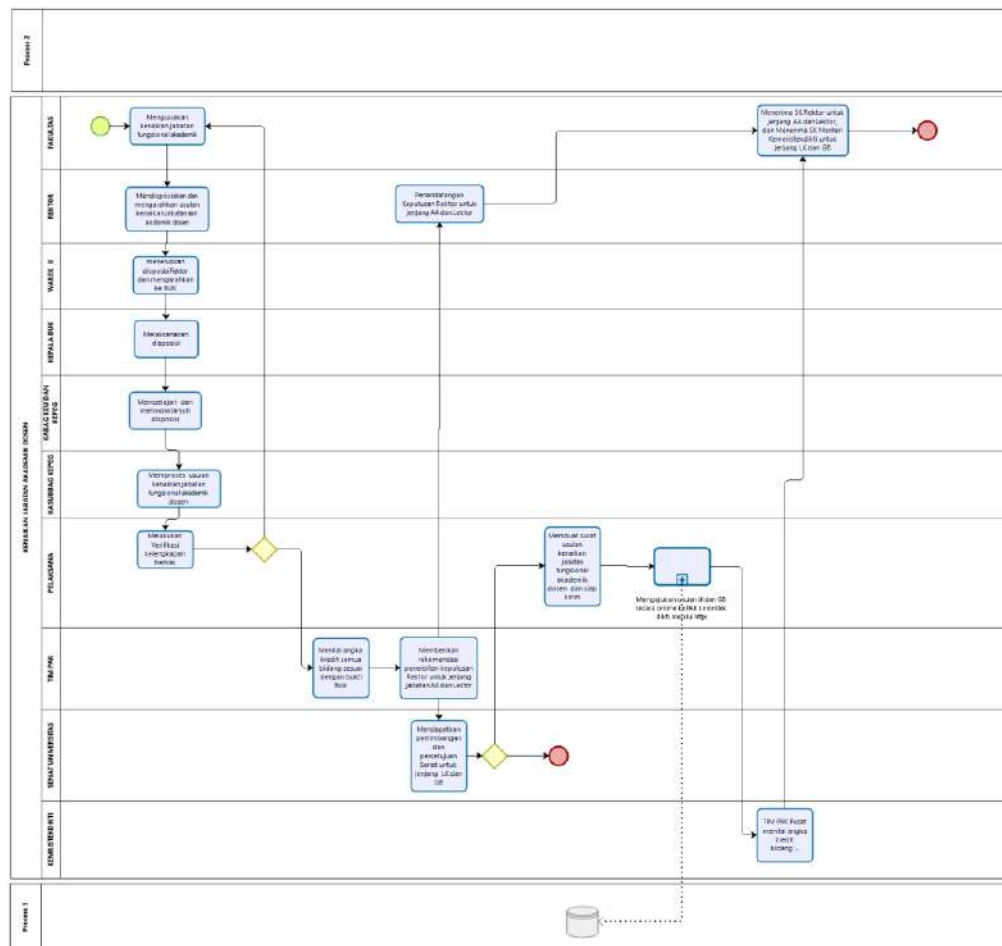

bizagi



# 66 SOP Layanan Pelaksanaan UTSUAS

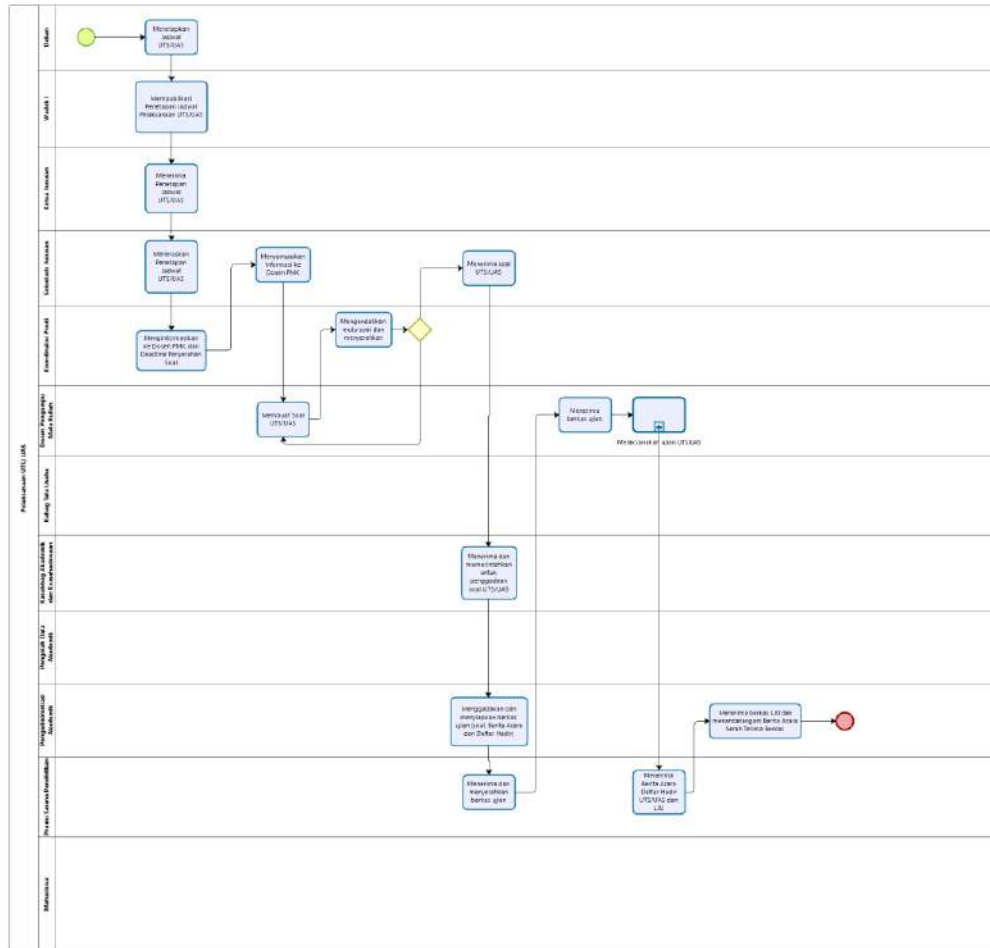



## 67 SOP Layanan pemakaian mobil Dinas

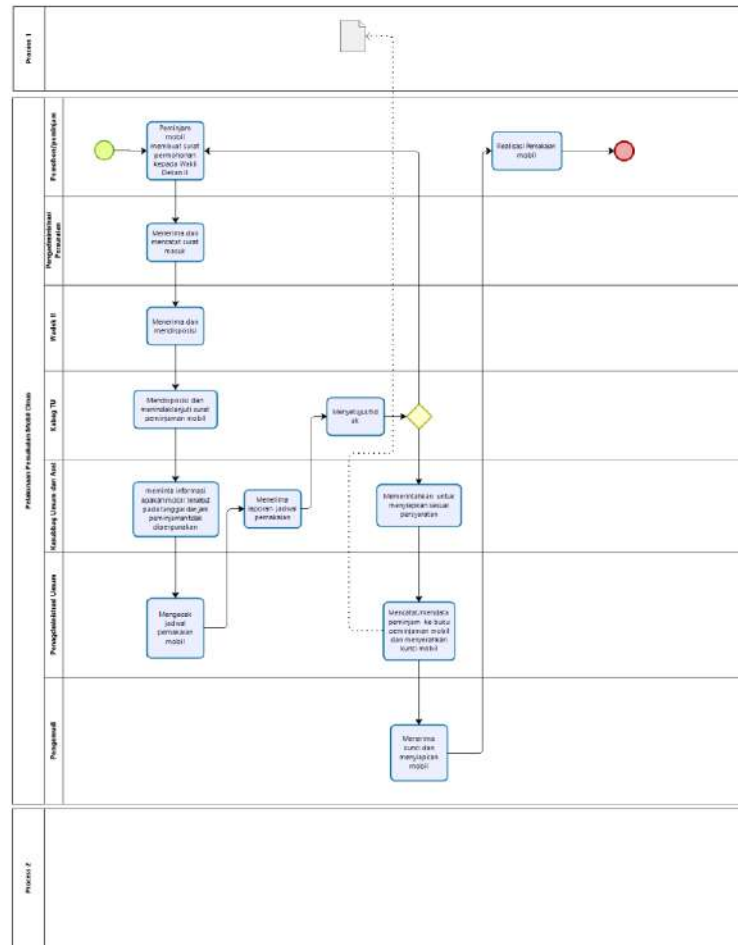



## 68 SOP Layanan Pemakaian Ruang di Fakultas

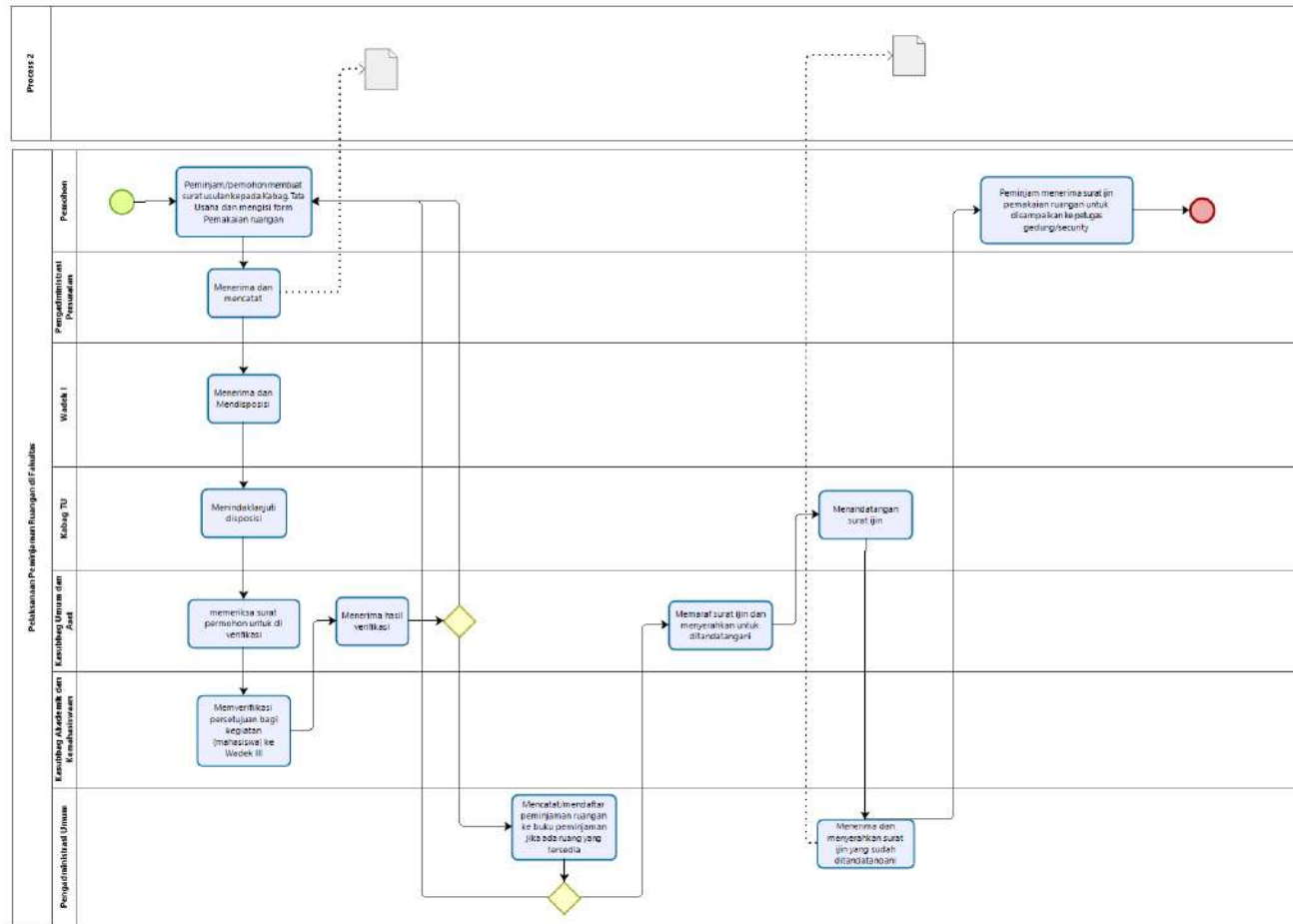



## 69 SOP Layanan Pembayaran Gaji

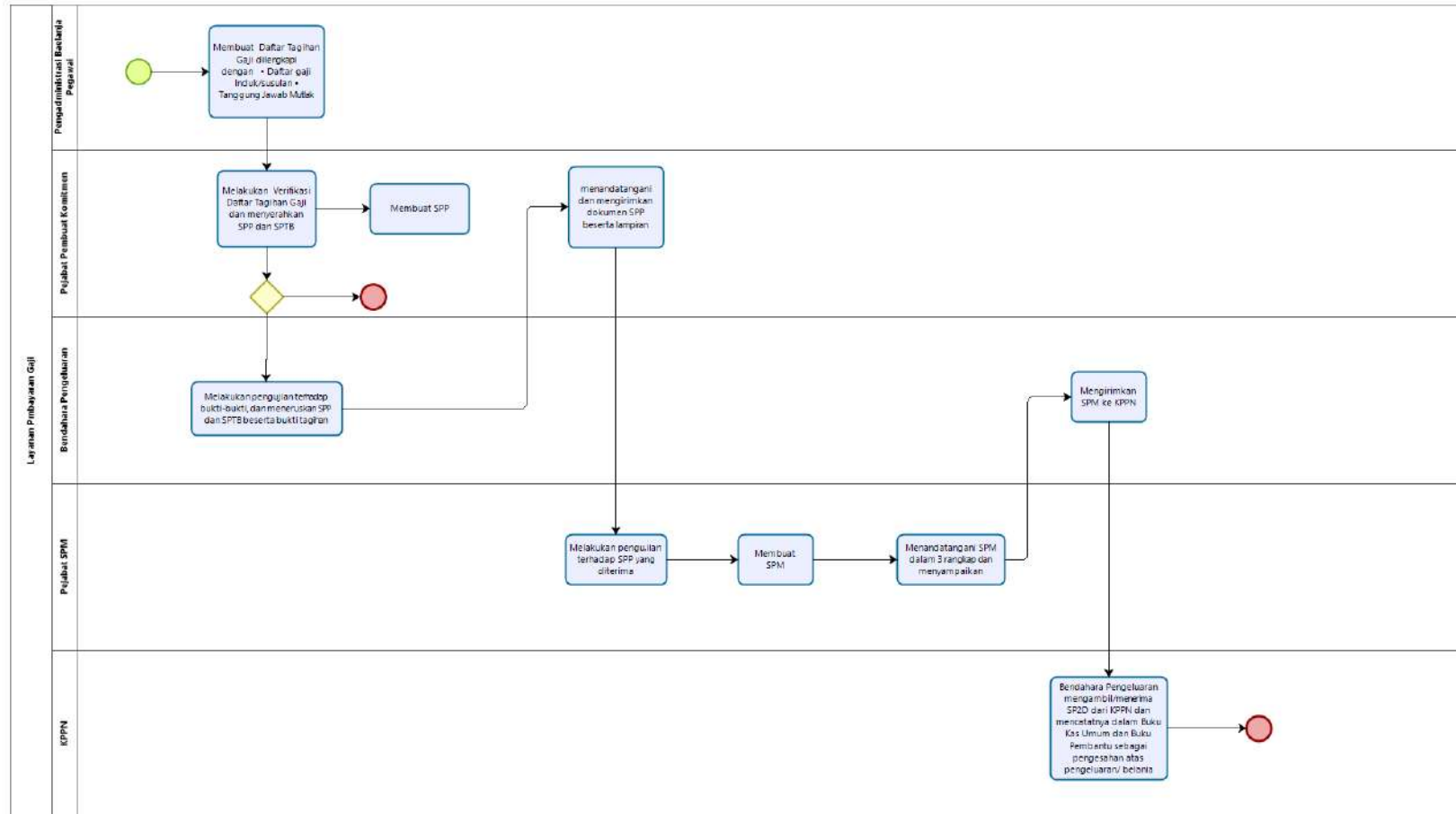





## 70 SOP Layanan Pembelian Konsumsi Rapat

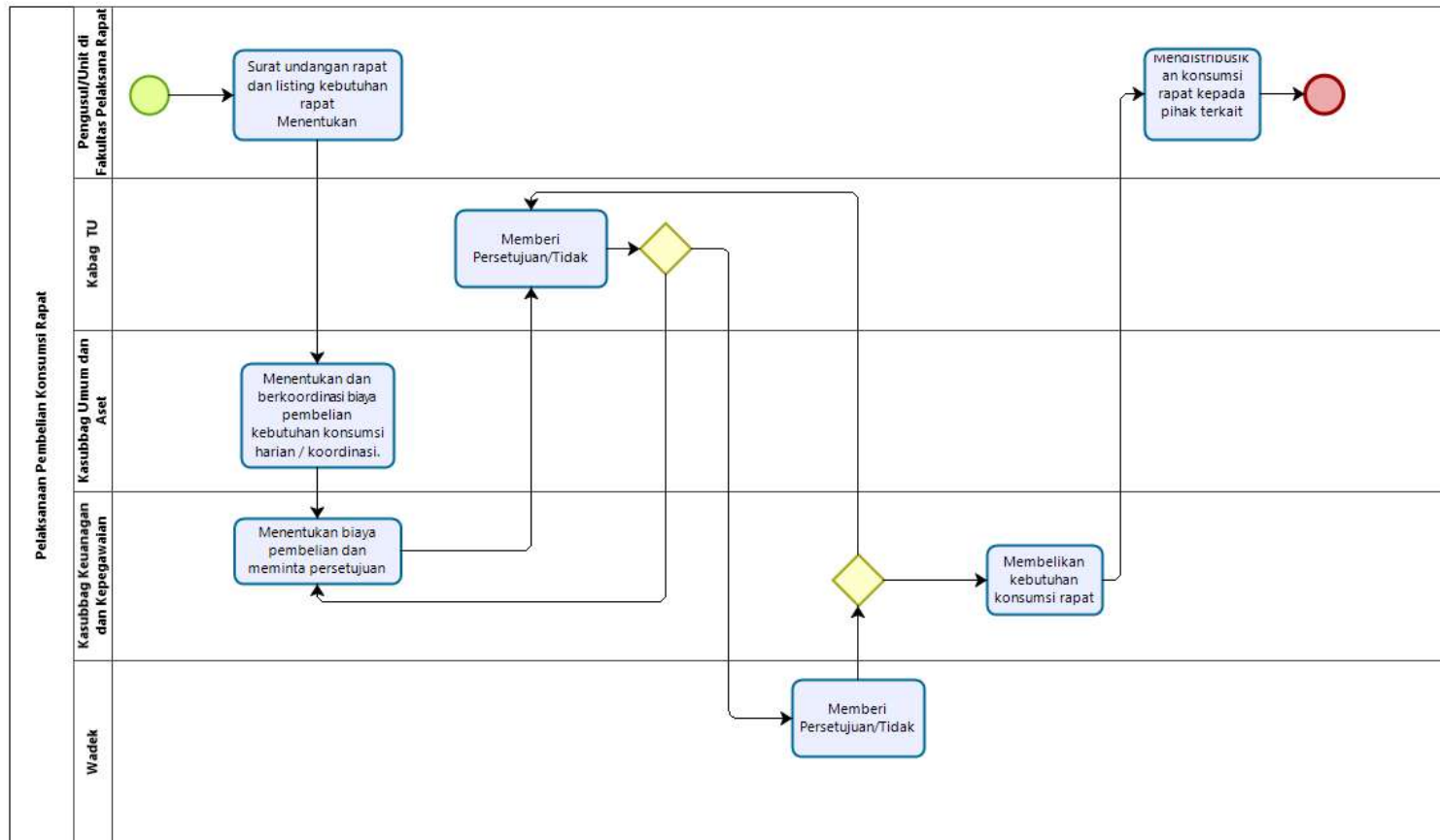



## 71 SOP Layanan Pemberlakuan Kurikulum

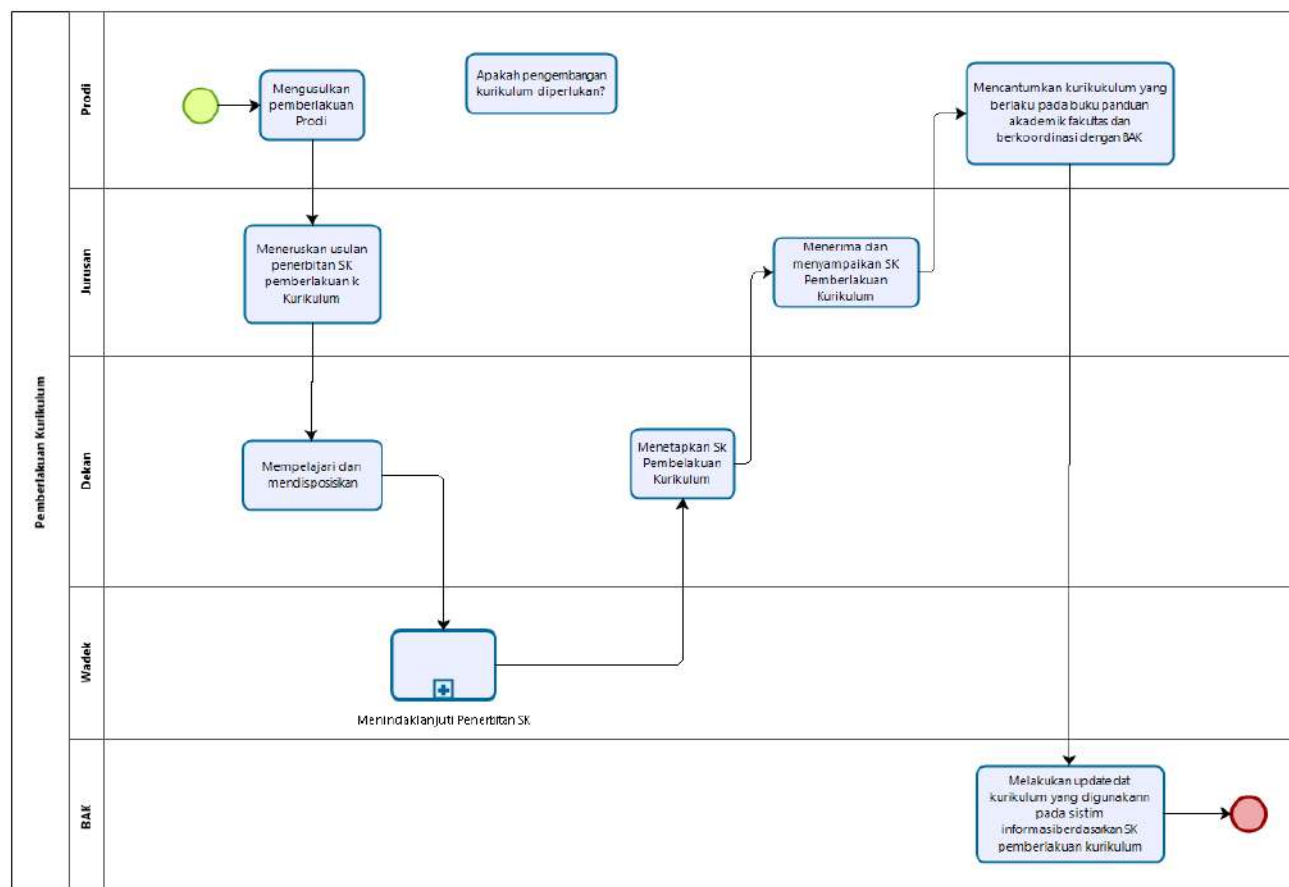



## 72 SOP Layanan pembinaan bagi dosen yang akan berakhir masa tugas belajar

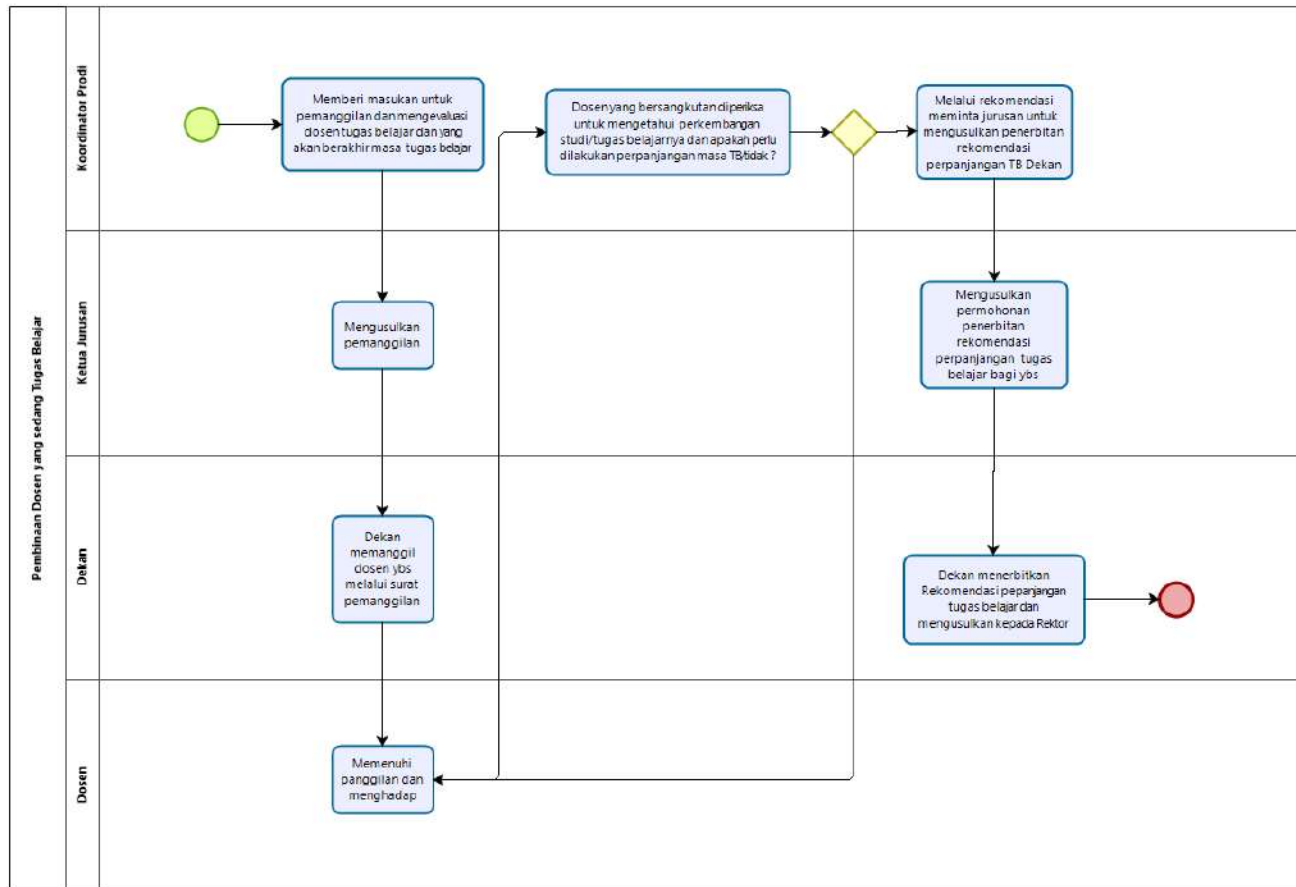



## 73 SOP Layanan Pemeliharaan dan Perbaikan

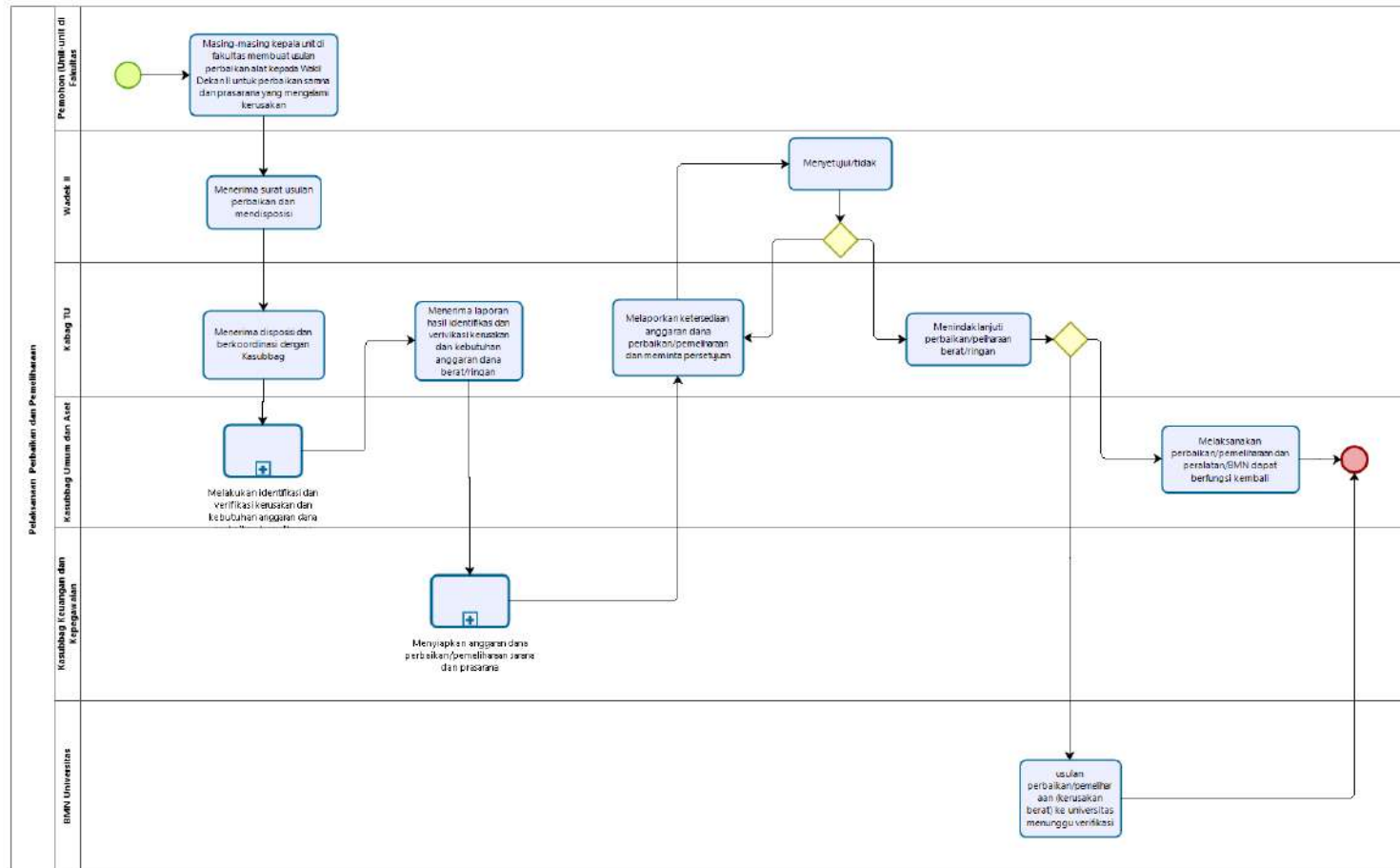



## 74 SOP Layanan Peminjaman Alat

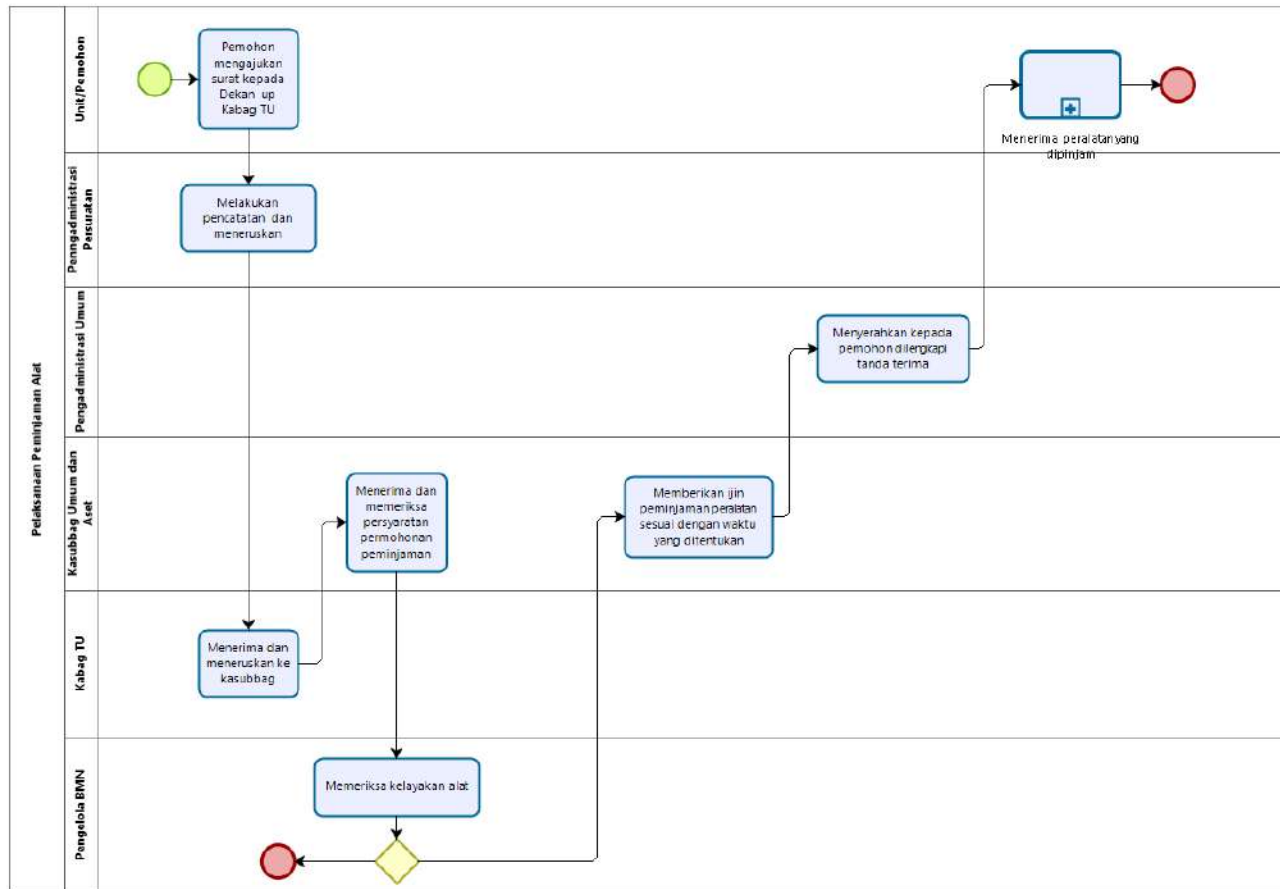



## 75 SOP Layanan Peminjaman Gedung dan Ruang UTM

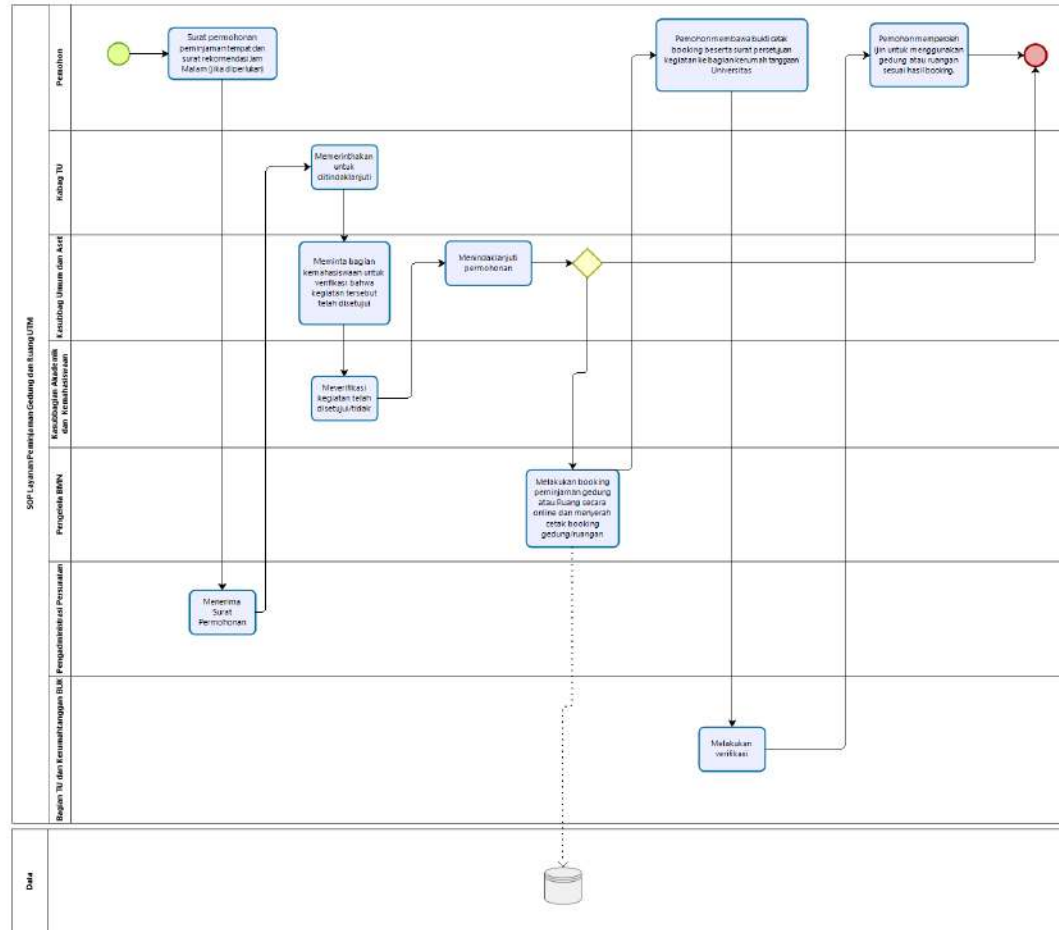



## 76 SOP Layanan Penentuan dosen Pembimbing TA

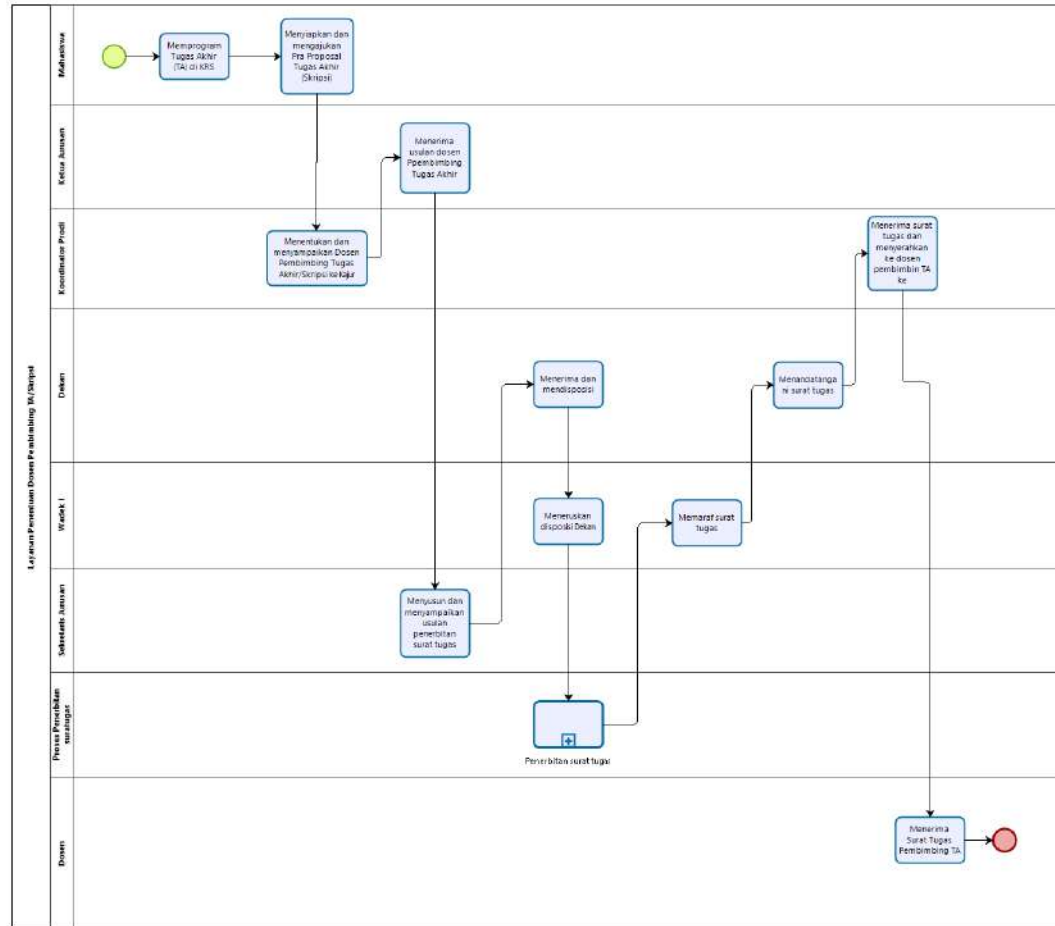



## 77 SOP Layanan Penerbitan Surat Tugas

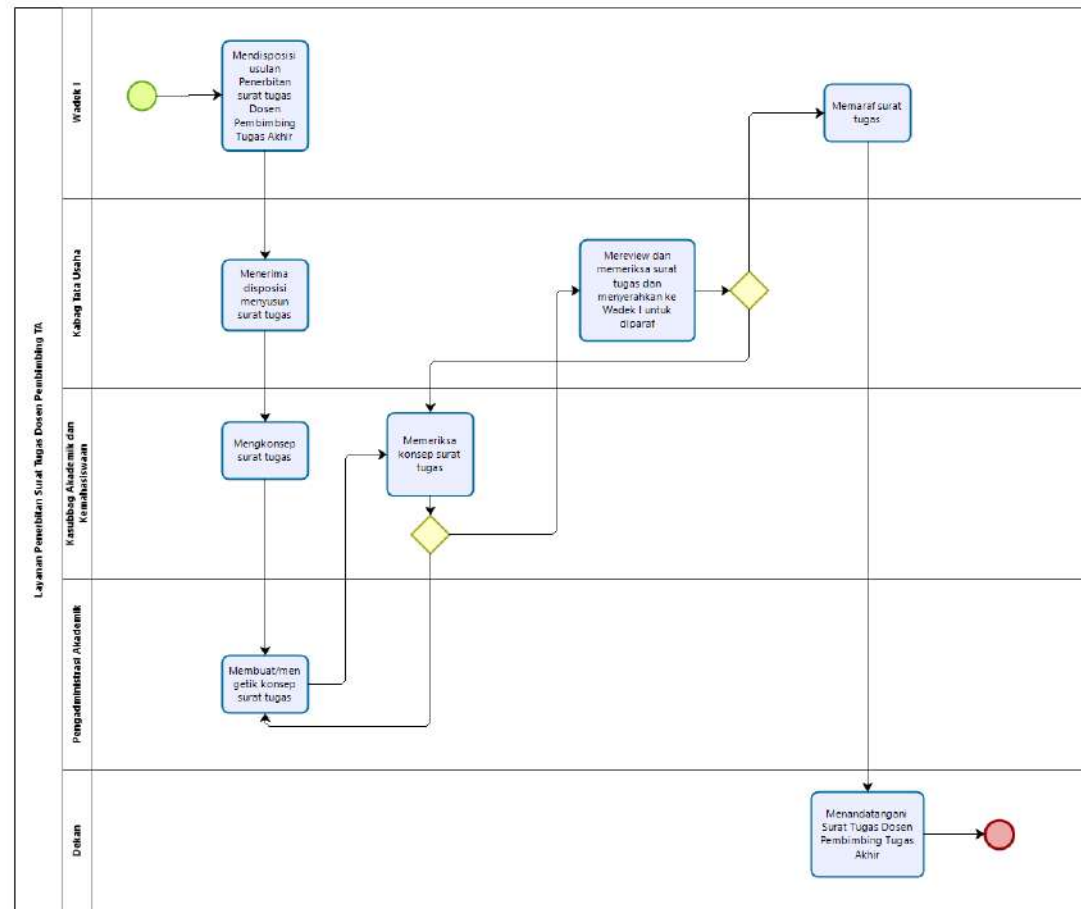





## 78 SOP Layanan Penetapan Jadwal dan Panitia UTSUAS

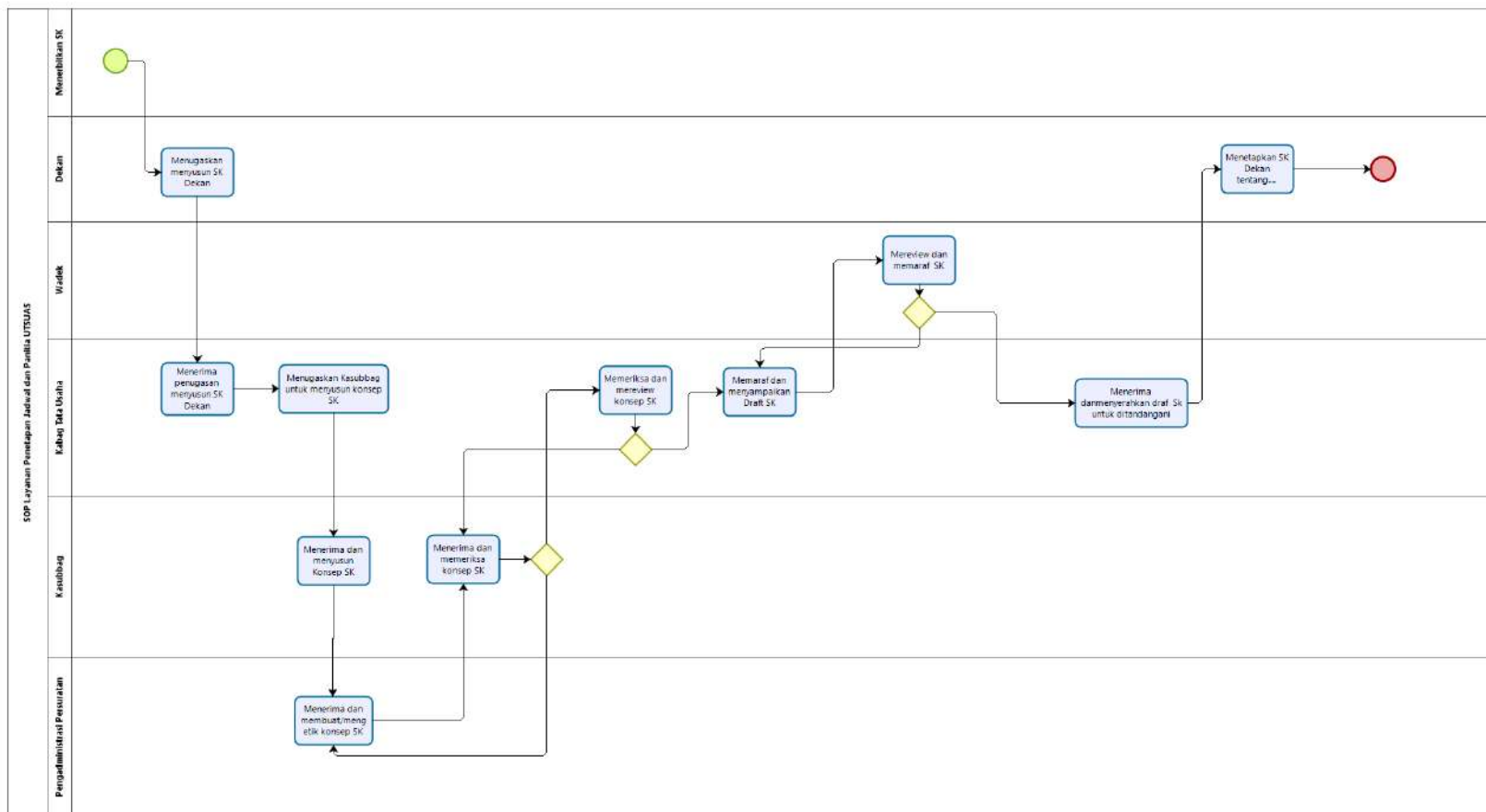



## 79 SOP Layanan Pengadaan Fakultas

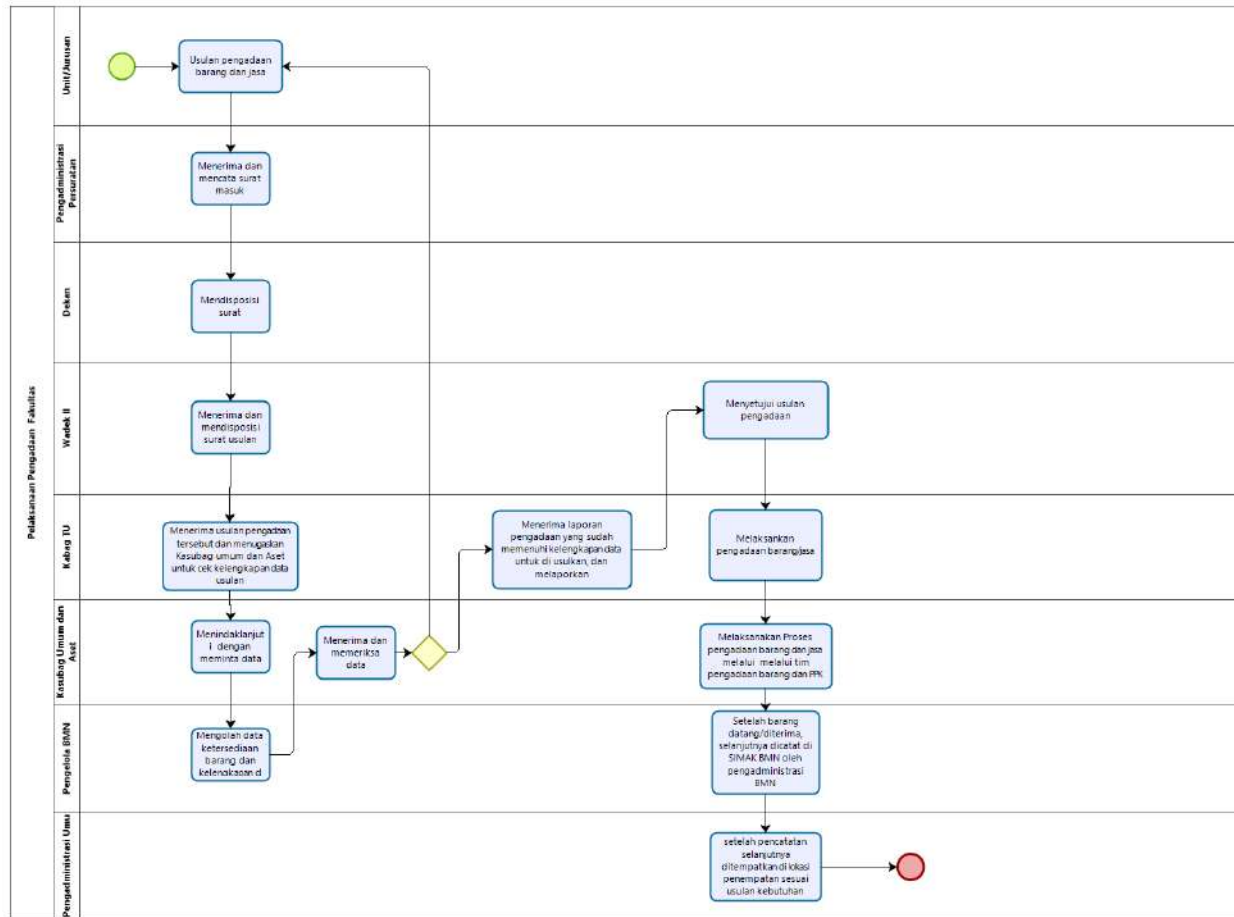



## 80 SOP Layanan Pengajuan Magang

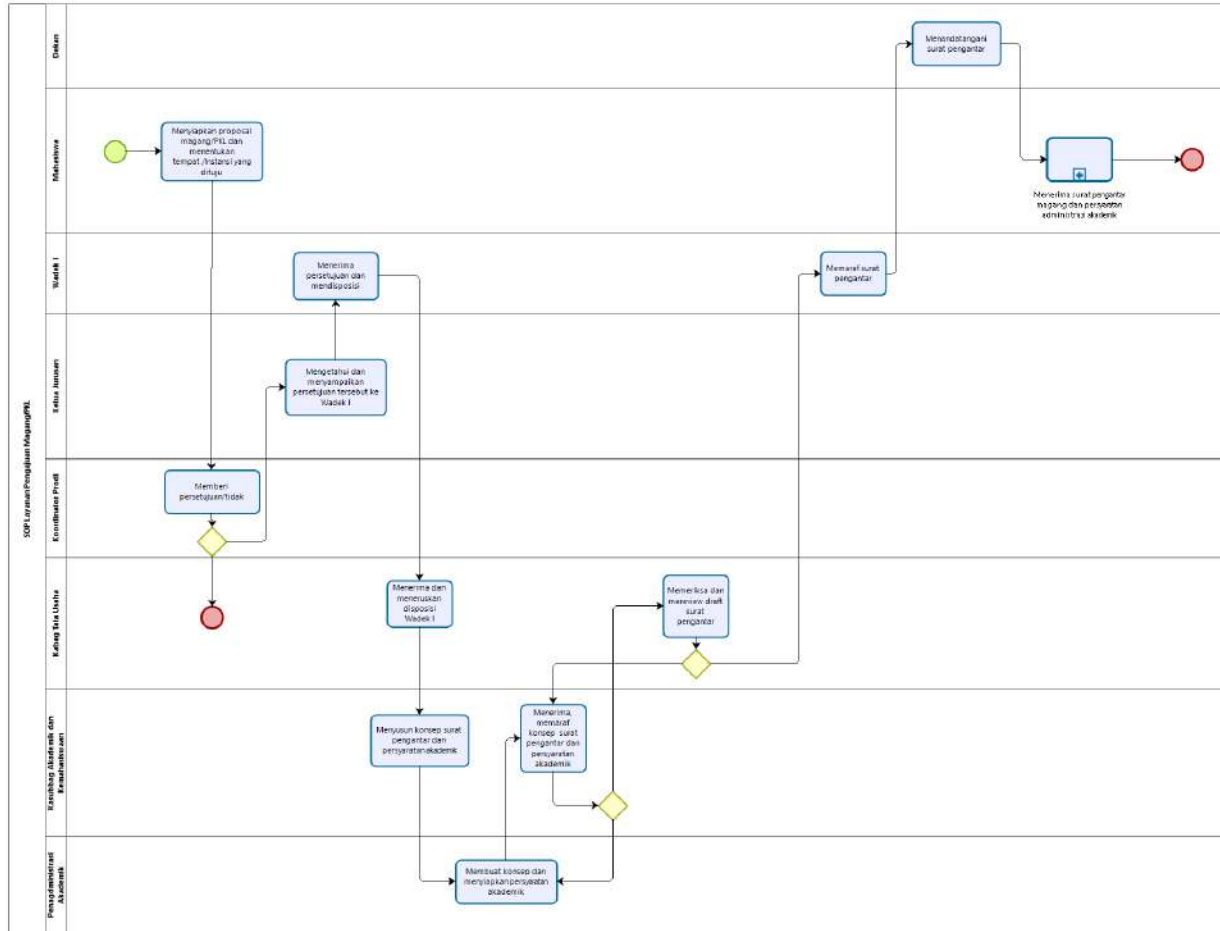





## 82 SOP Layanan Pengembalian Peminjaman Alat

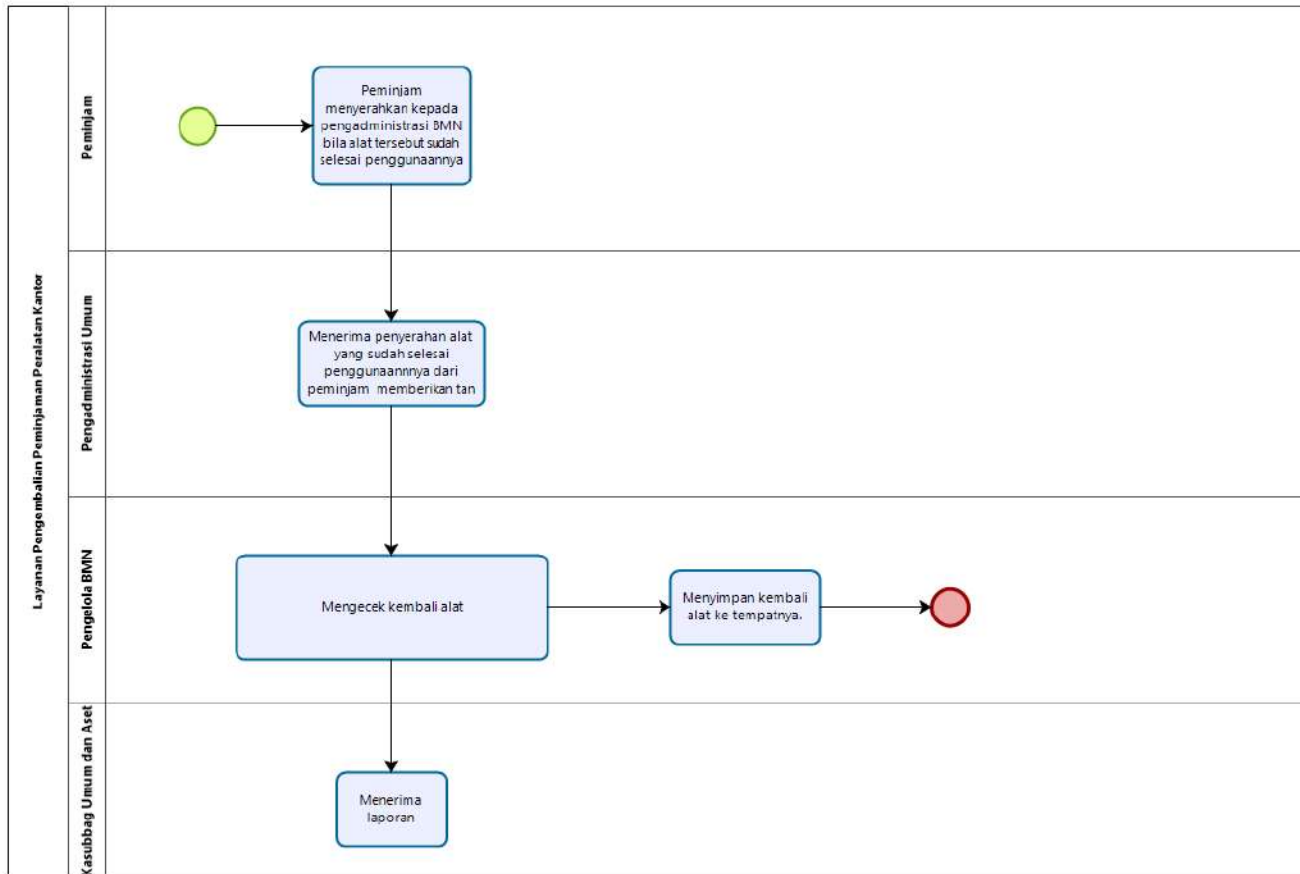



## 83 SOP Layanan Penggunaan Dana UP

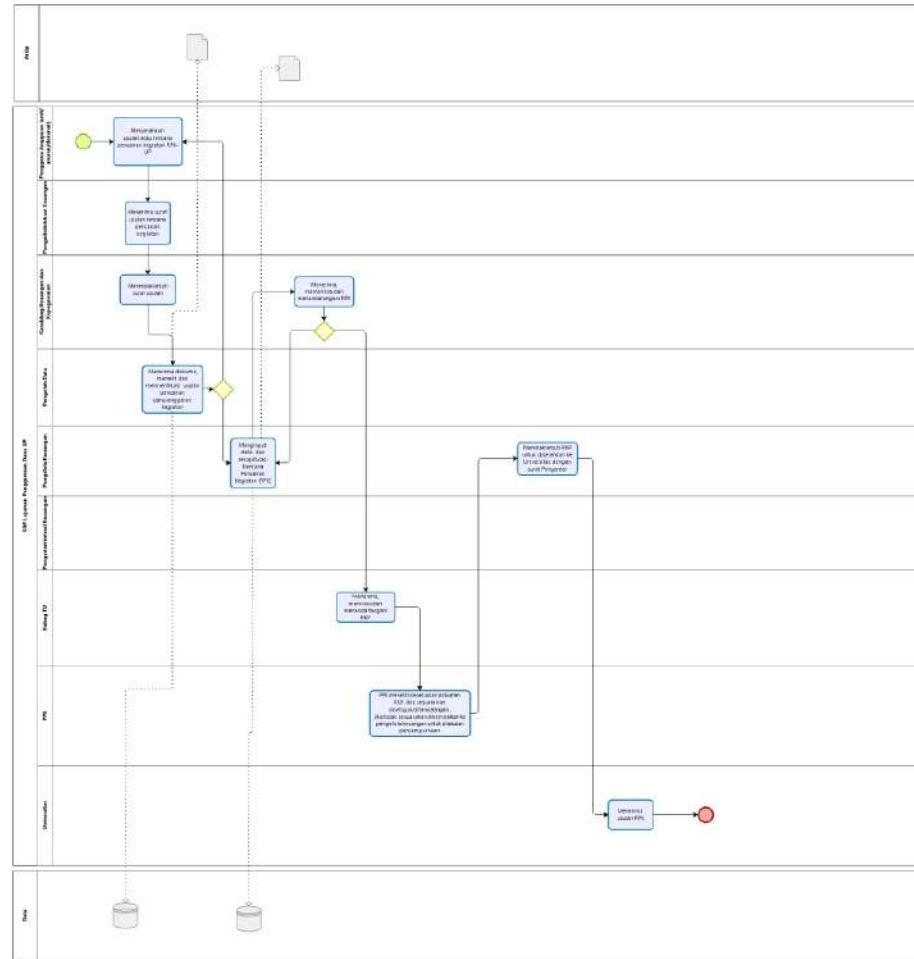



## 84 SOP Layanan Pengisian KPRS

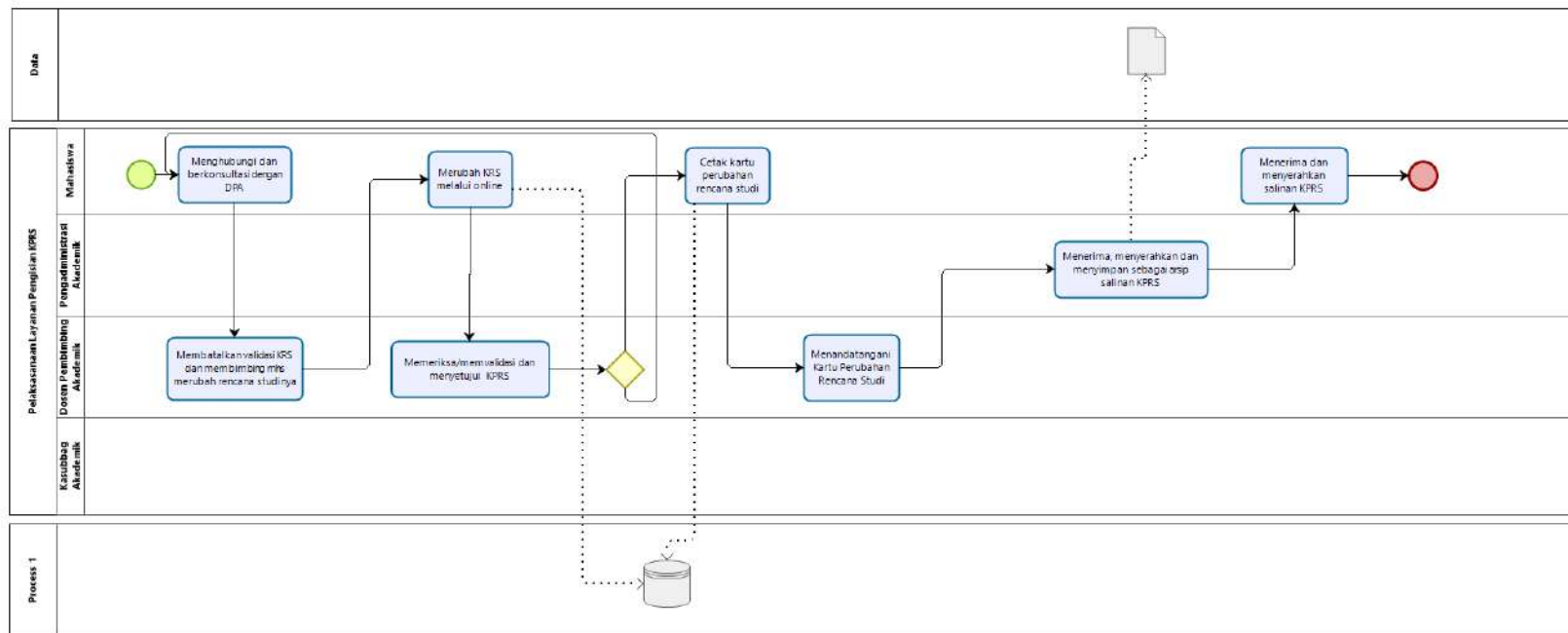



## 85 SOP Layanan Pengisian KRS

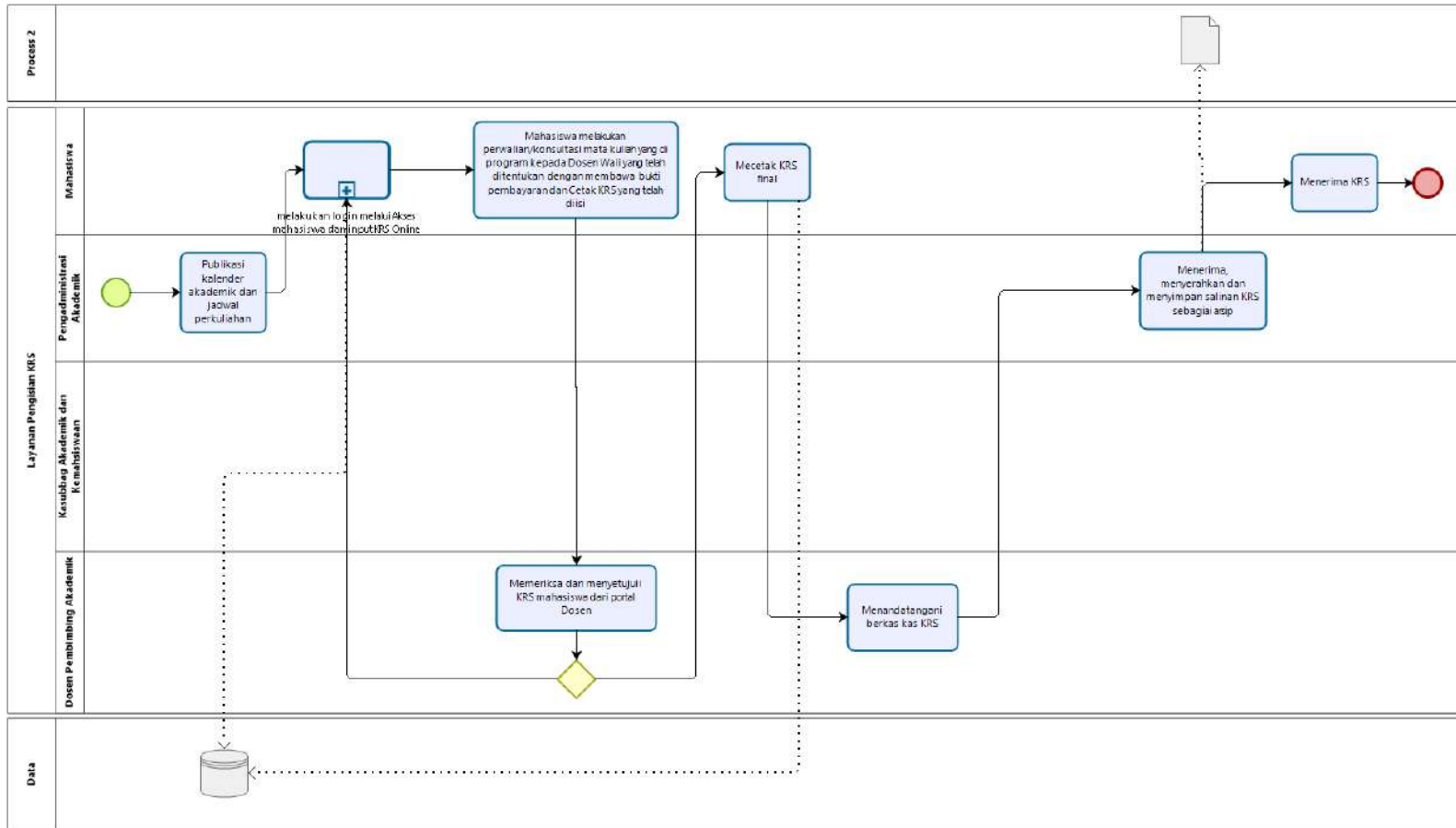





## 86 SOP Layanan Peninjauan Kurikulum

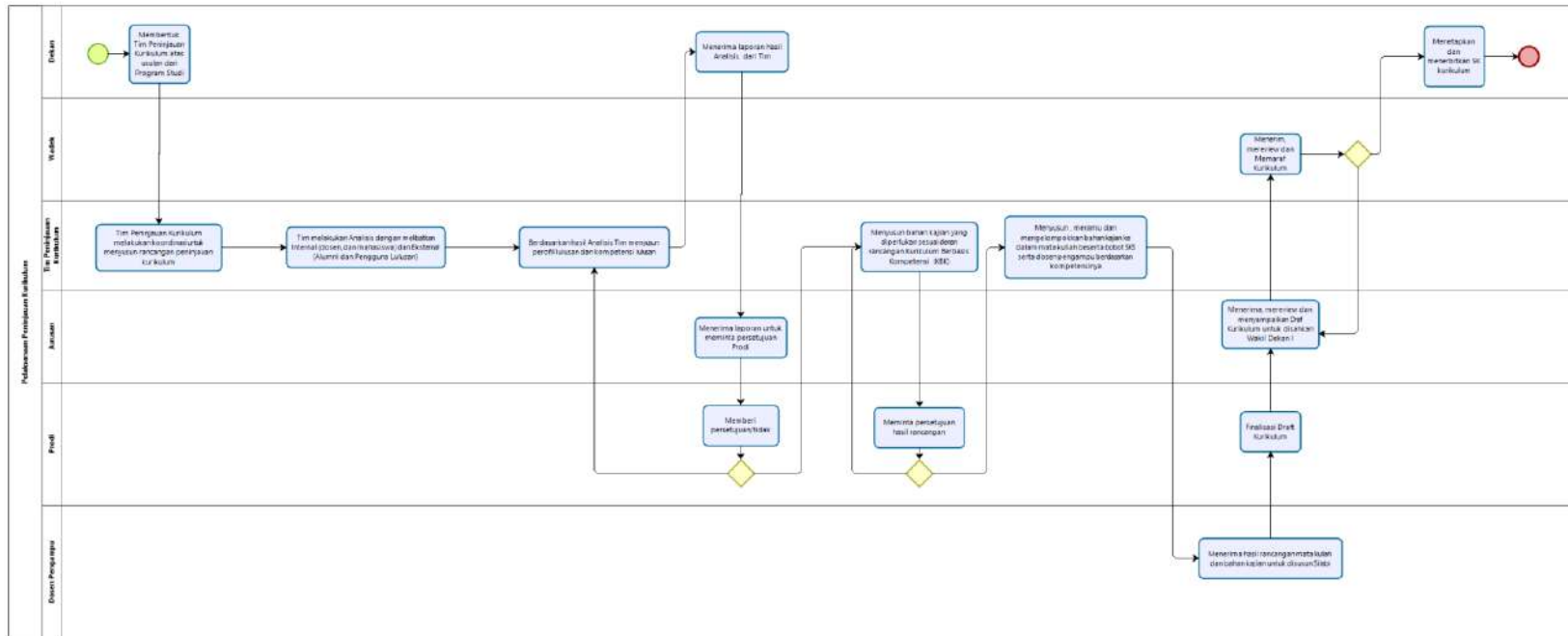



## 87 SOP Layanan Penyusunan Jadwal UTS atau UAS

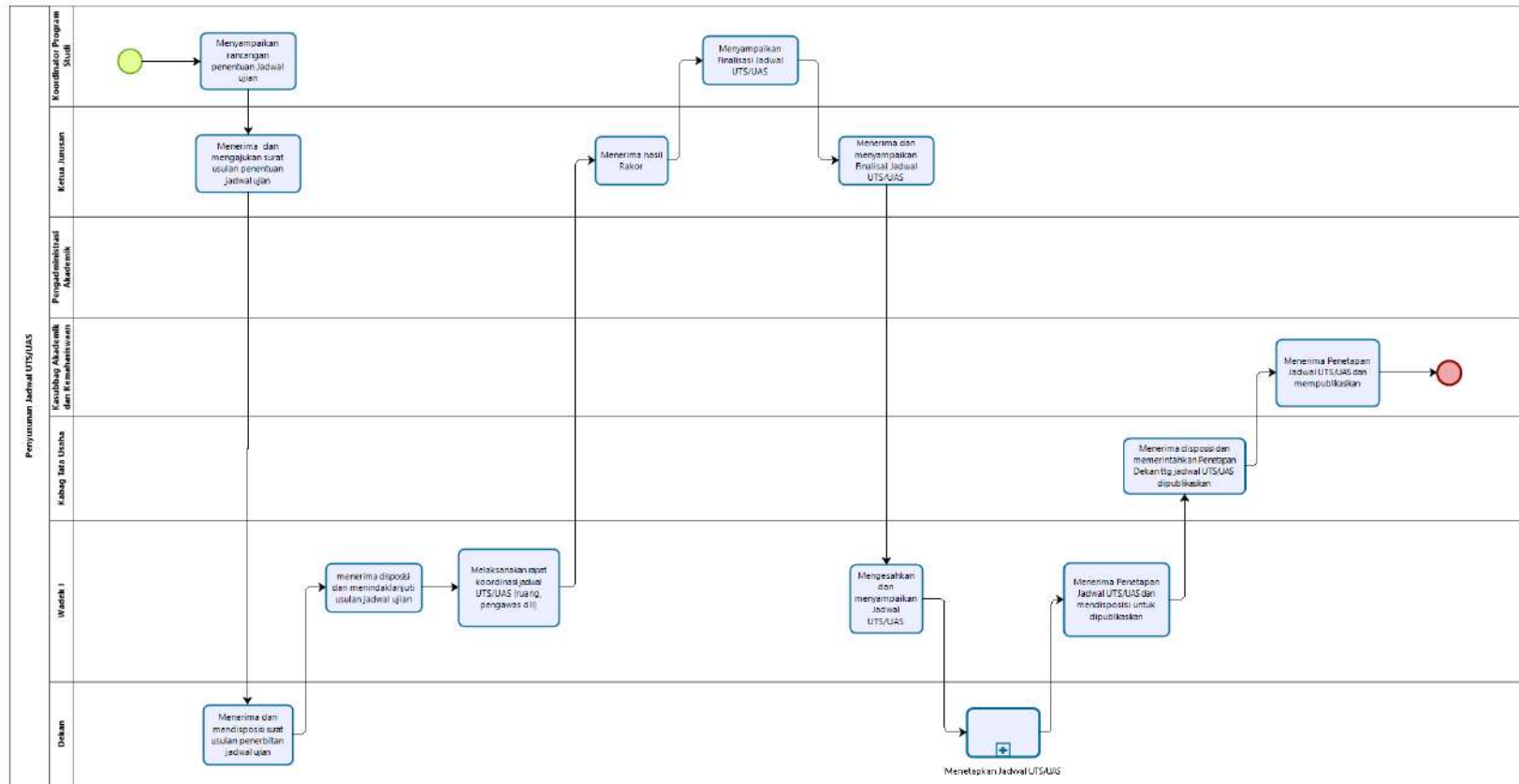





## 89 SOP Layanan Perencanaan Tugas Belajar dosen

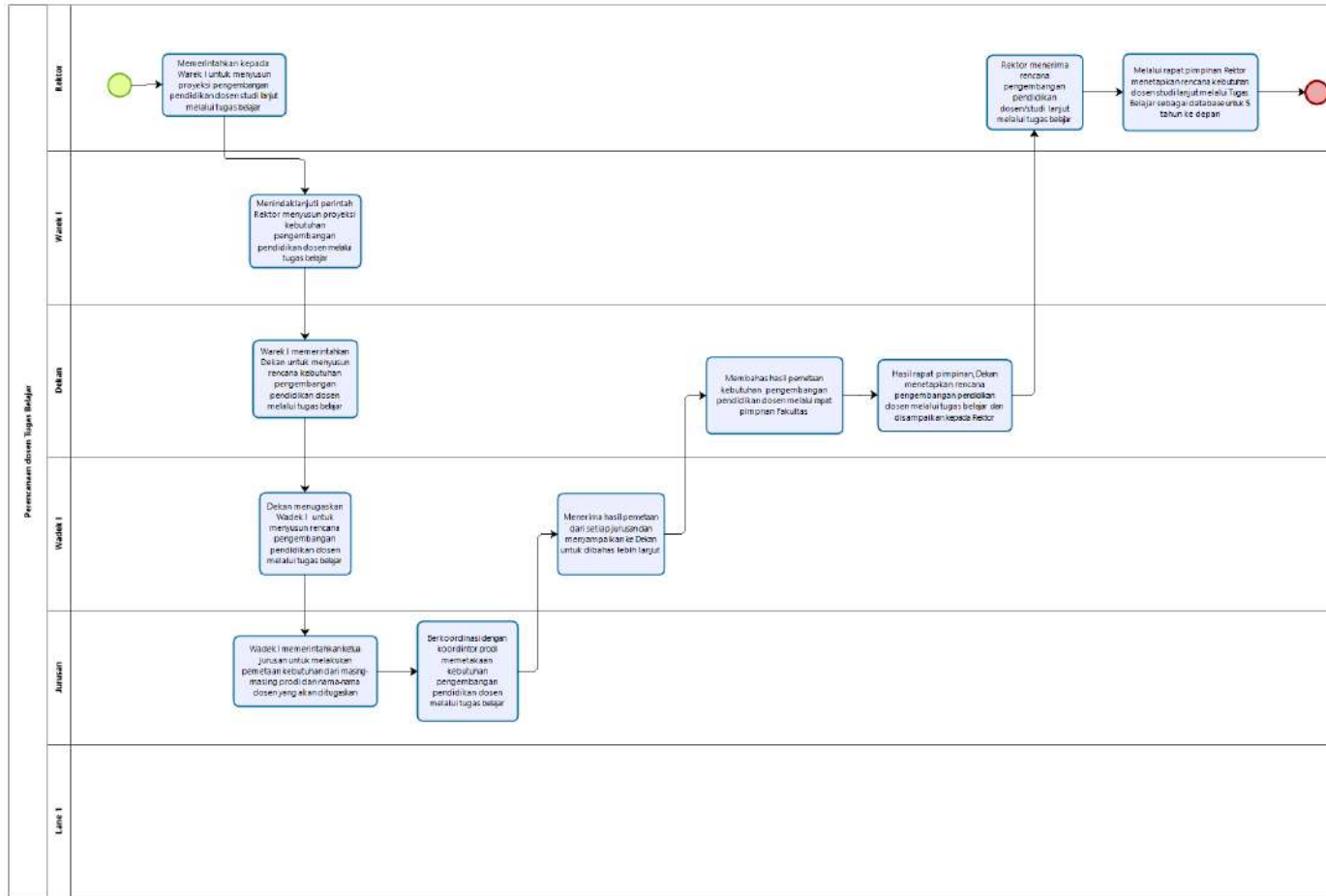

## 90 SOP Layanan Perpanjangan Karyawan Kontrak

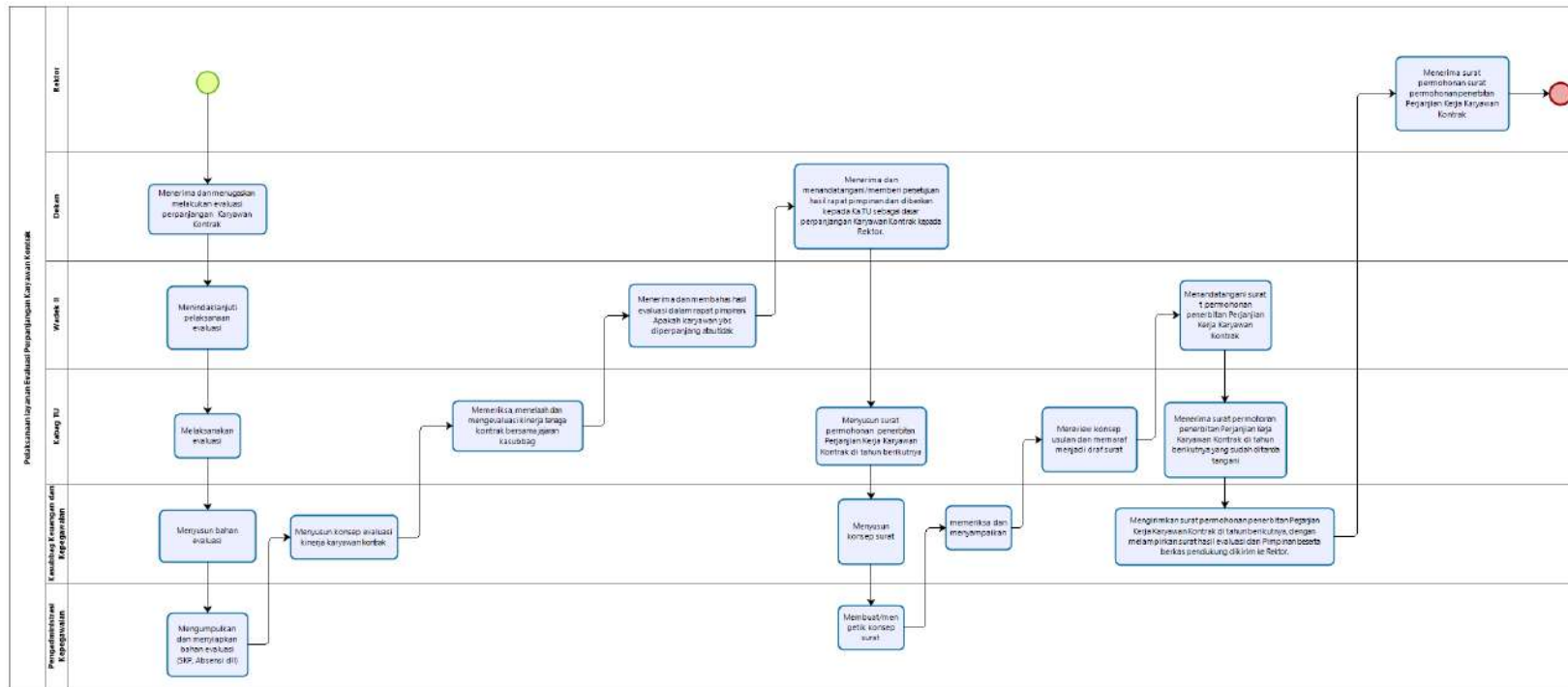



## 91 SOP Layanan Referensi

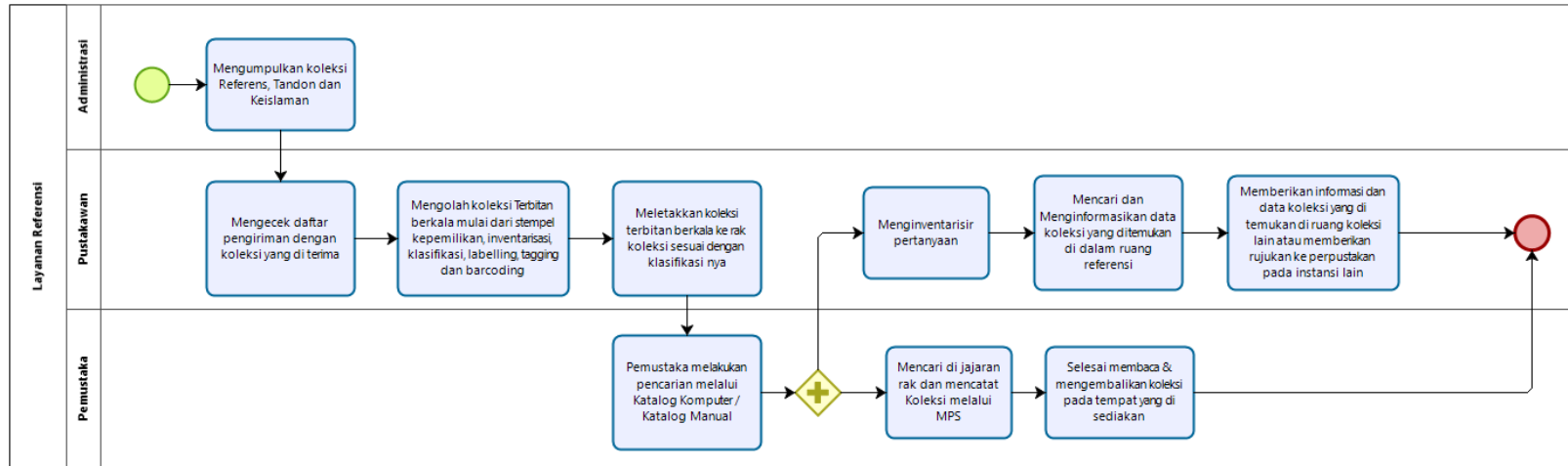



## 92 SOP Layanan Rencana Pelaksanaan Praktikum

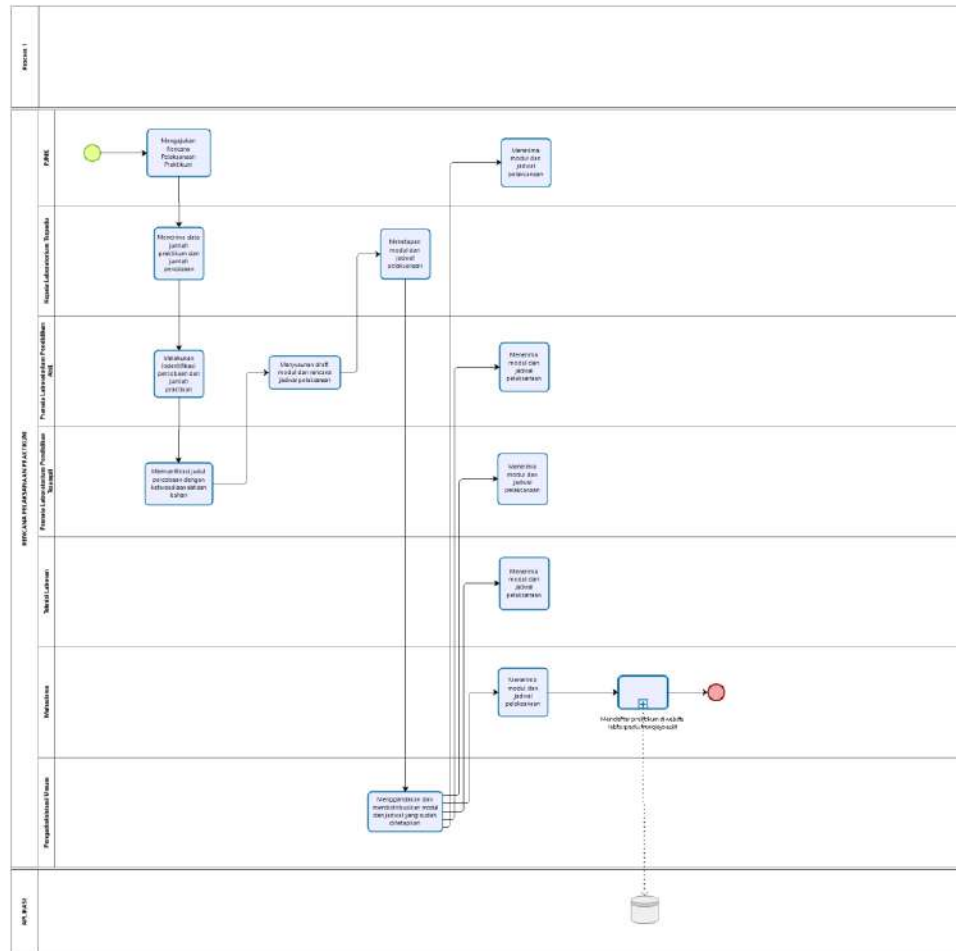



### 93 SOP Layanan Review, Asistensi, Konsultasi, Sosialisasi

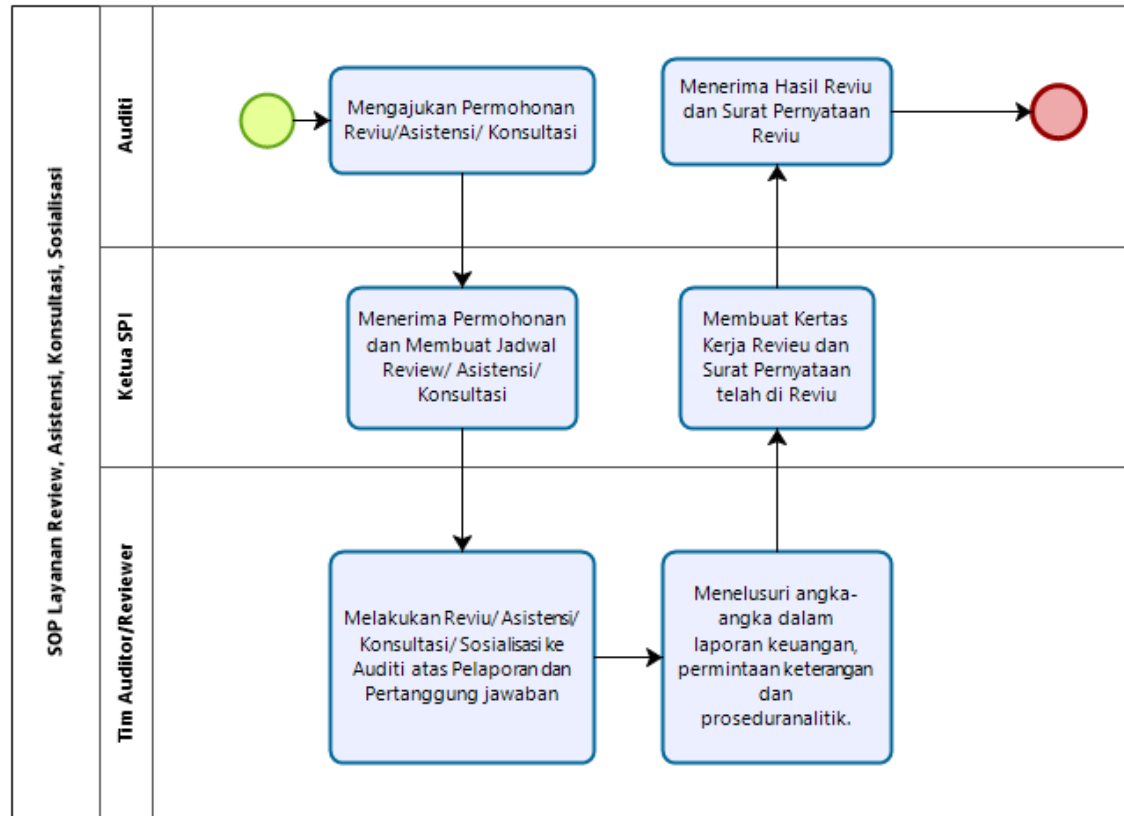





## 94 SOP Layanan surat tugas dosen pembimbing magang

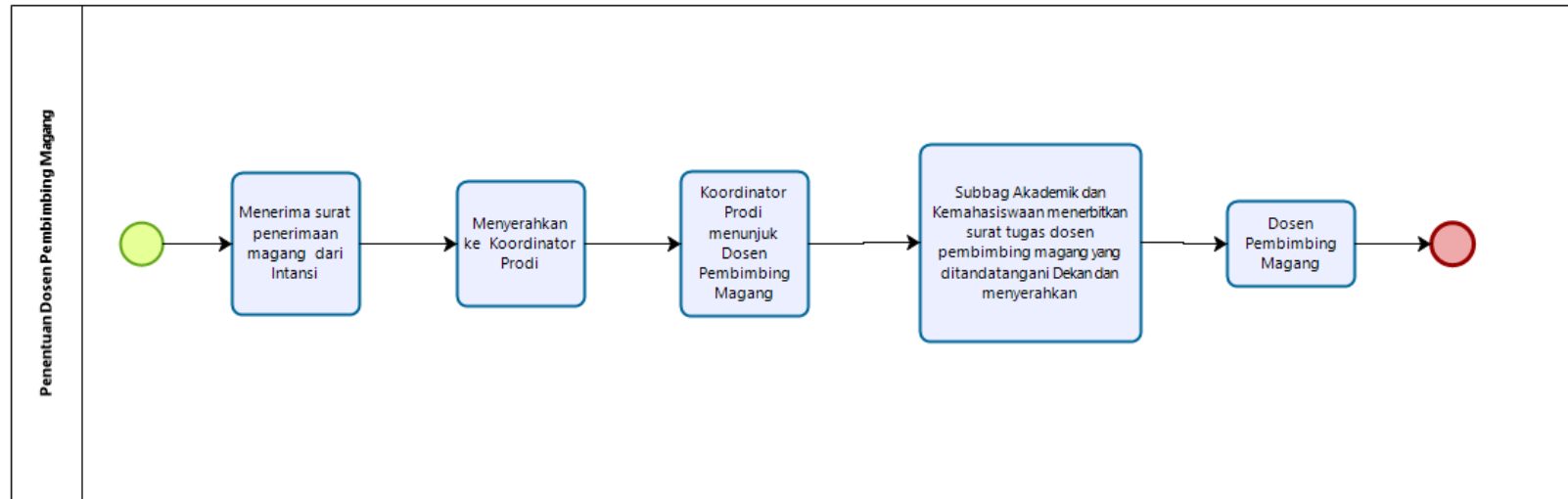



## 95 SOP Layanan Terbitan Berkala(Tugas AkhirSkripsi)

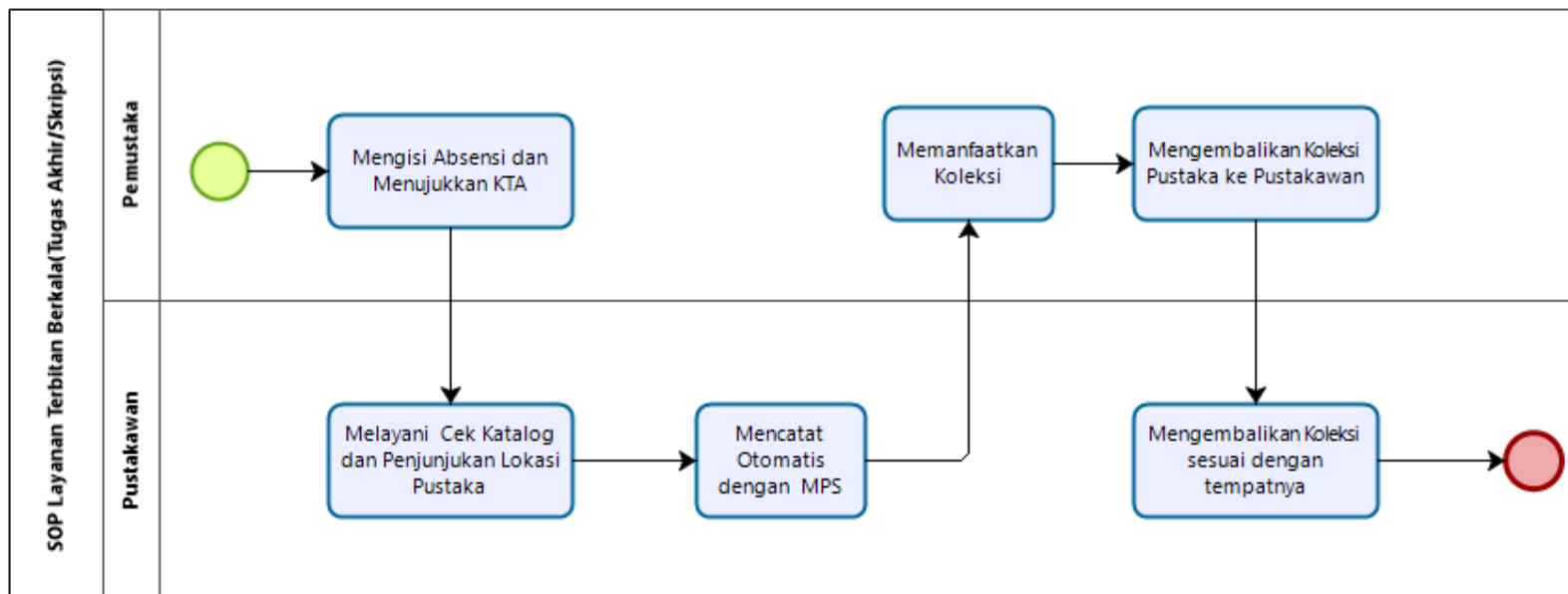



## 96 SOP Layanan Terima Buku

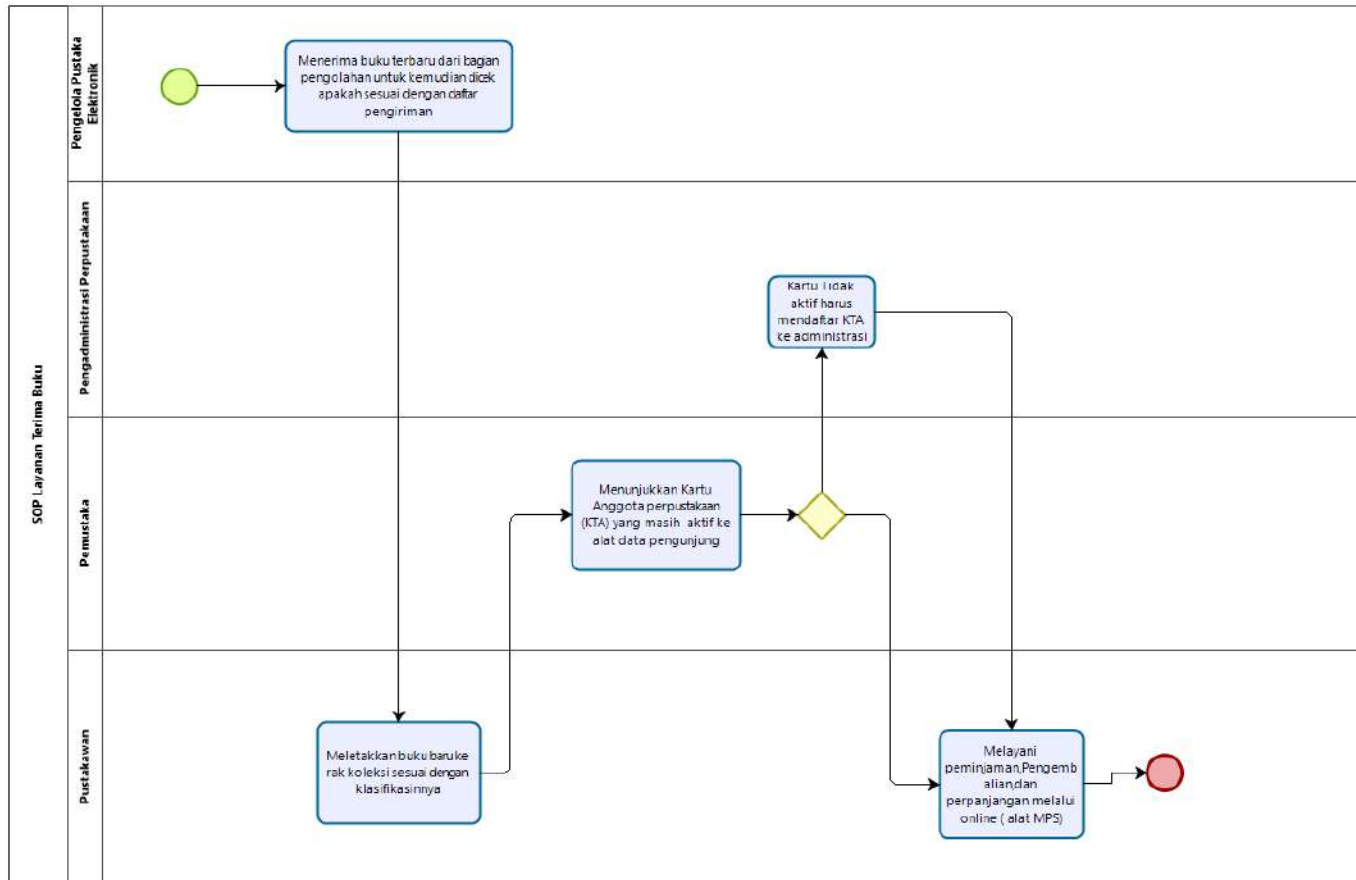



## 97 SOP Layanan Usulan KP

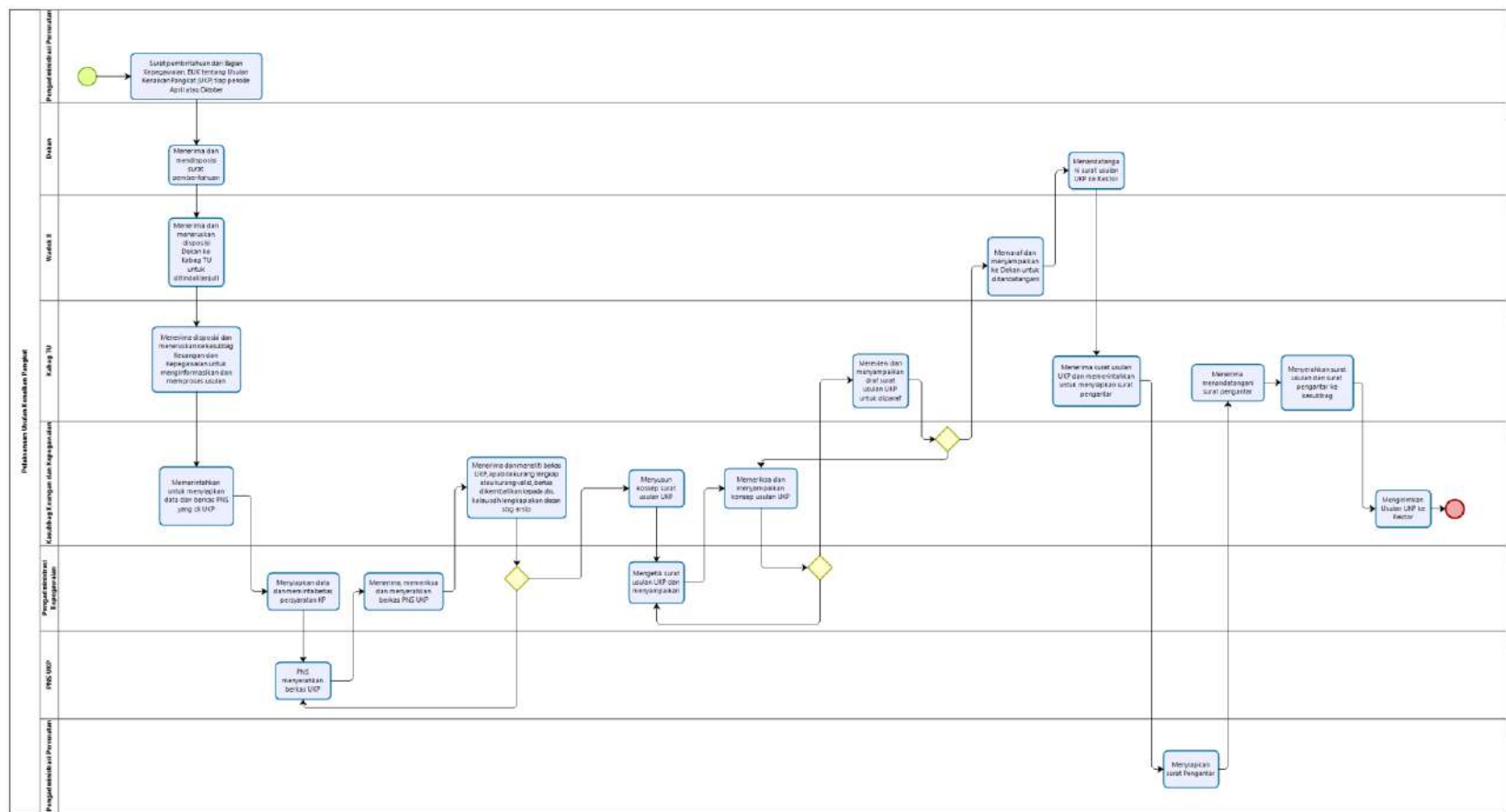



# 98 SOP layanan usulan tugas belajar fakultas

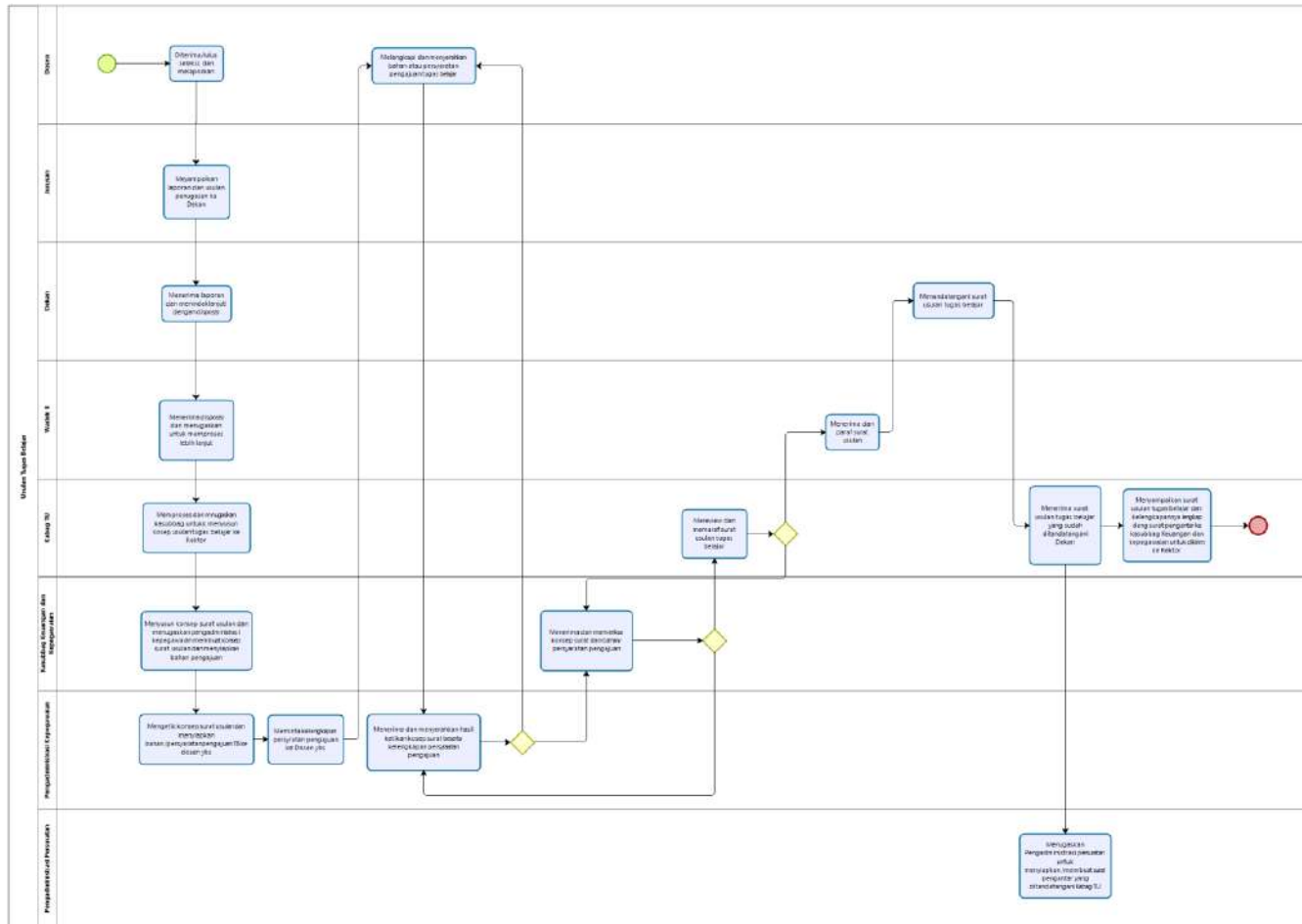



## 99 SOP Layanan Validasi Ketidakhadiran Mahasiswa

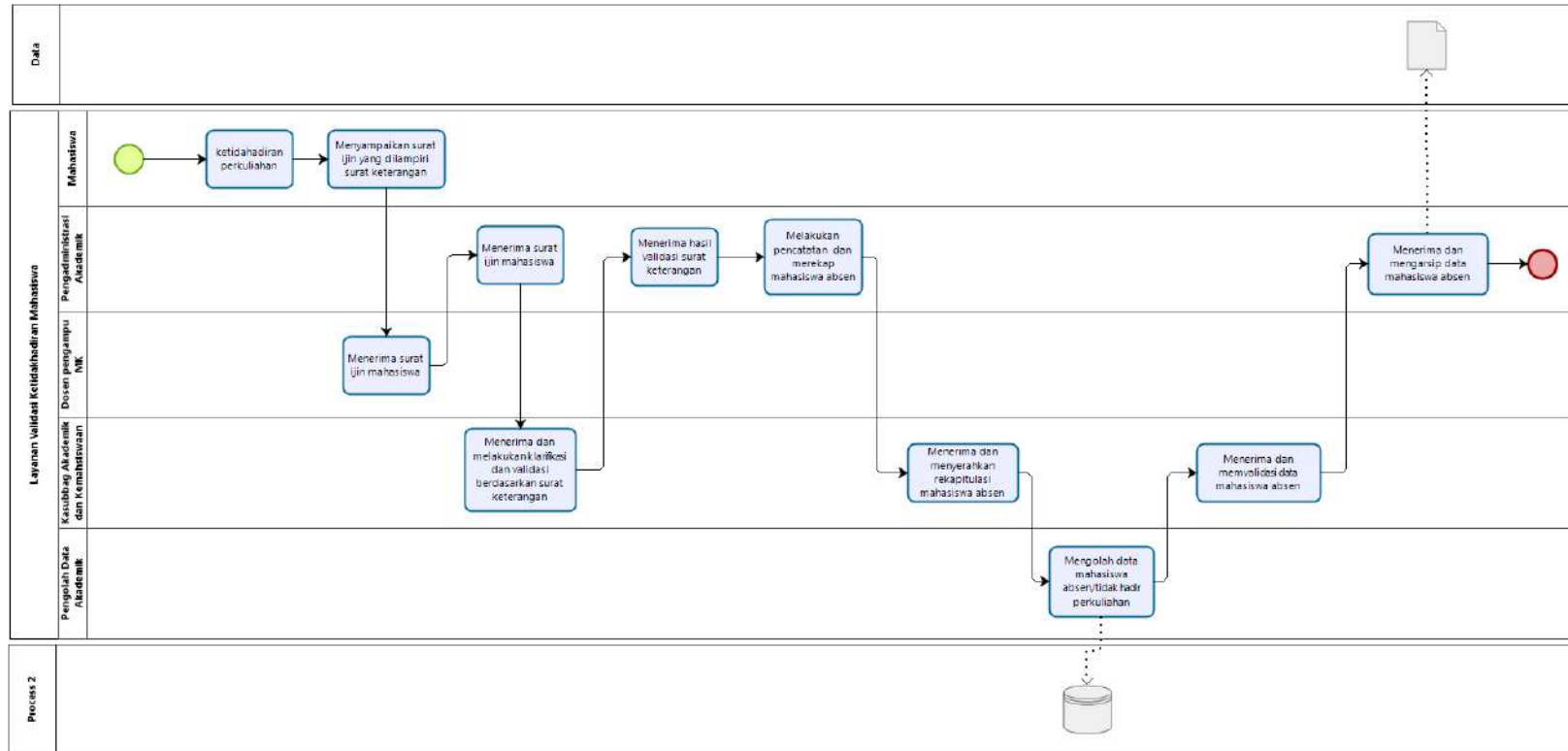



## 100 SOP Layanan Verifikasi dan Identifikasi anggaran Perbaikan

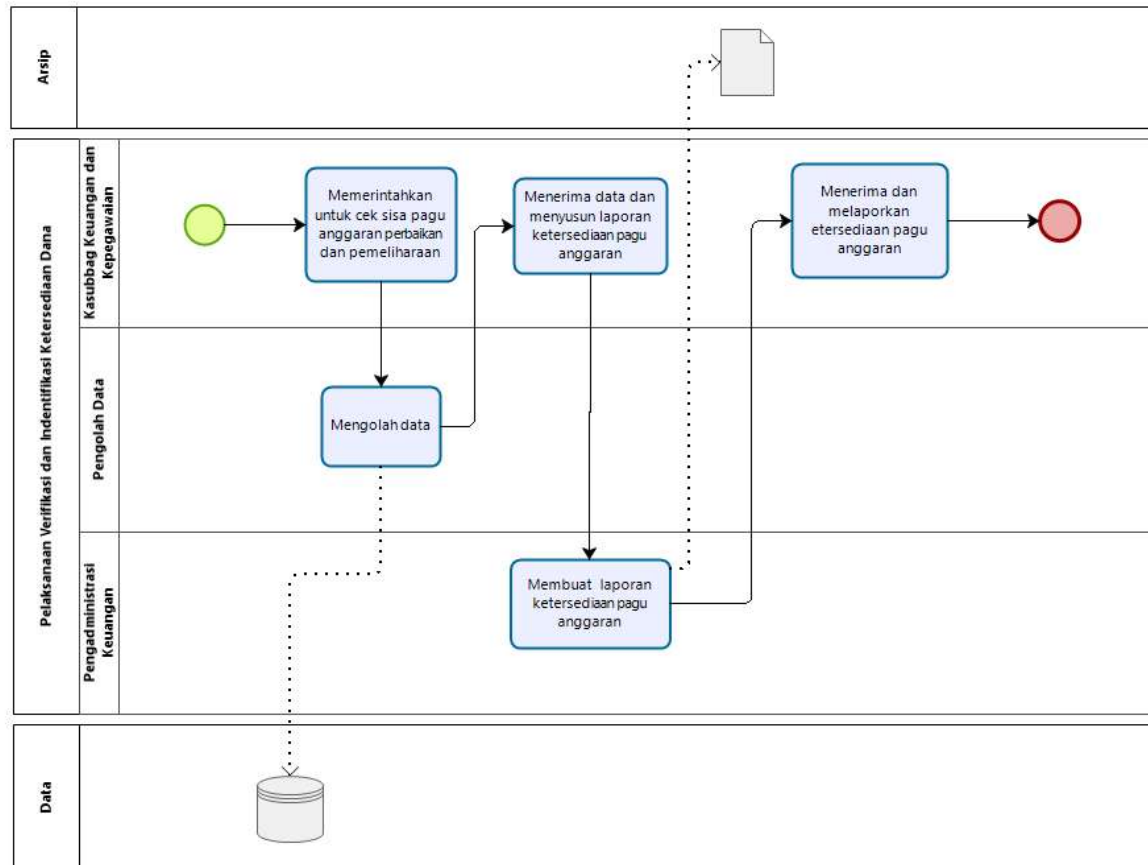



# 101 SOP Monev Abdimas

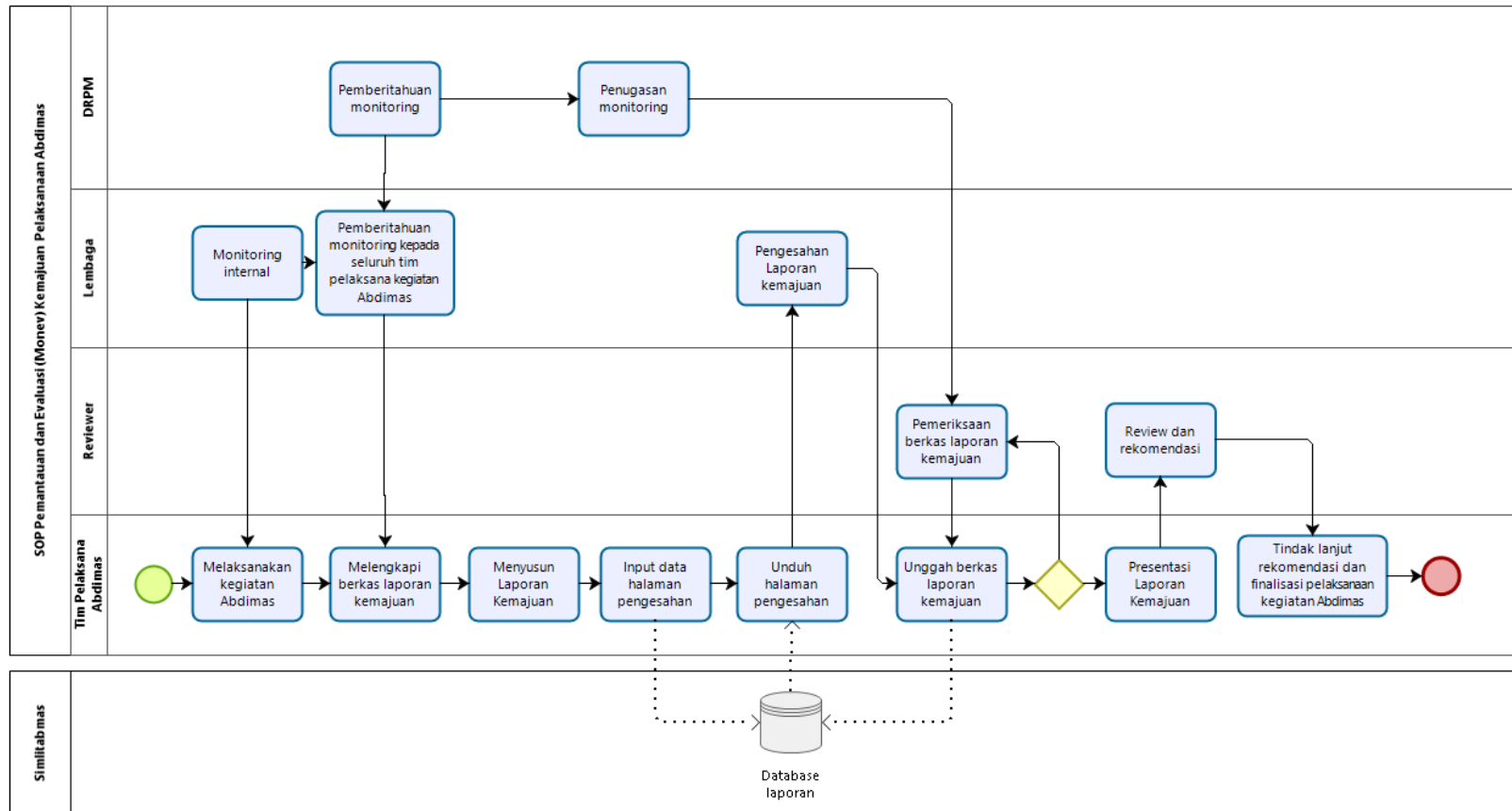





# 102 SOP Monitoring dan Evaluasi Penelitian Kompetitif Nasional, Desentralisasi dan Penugasan

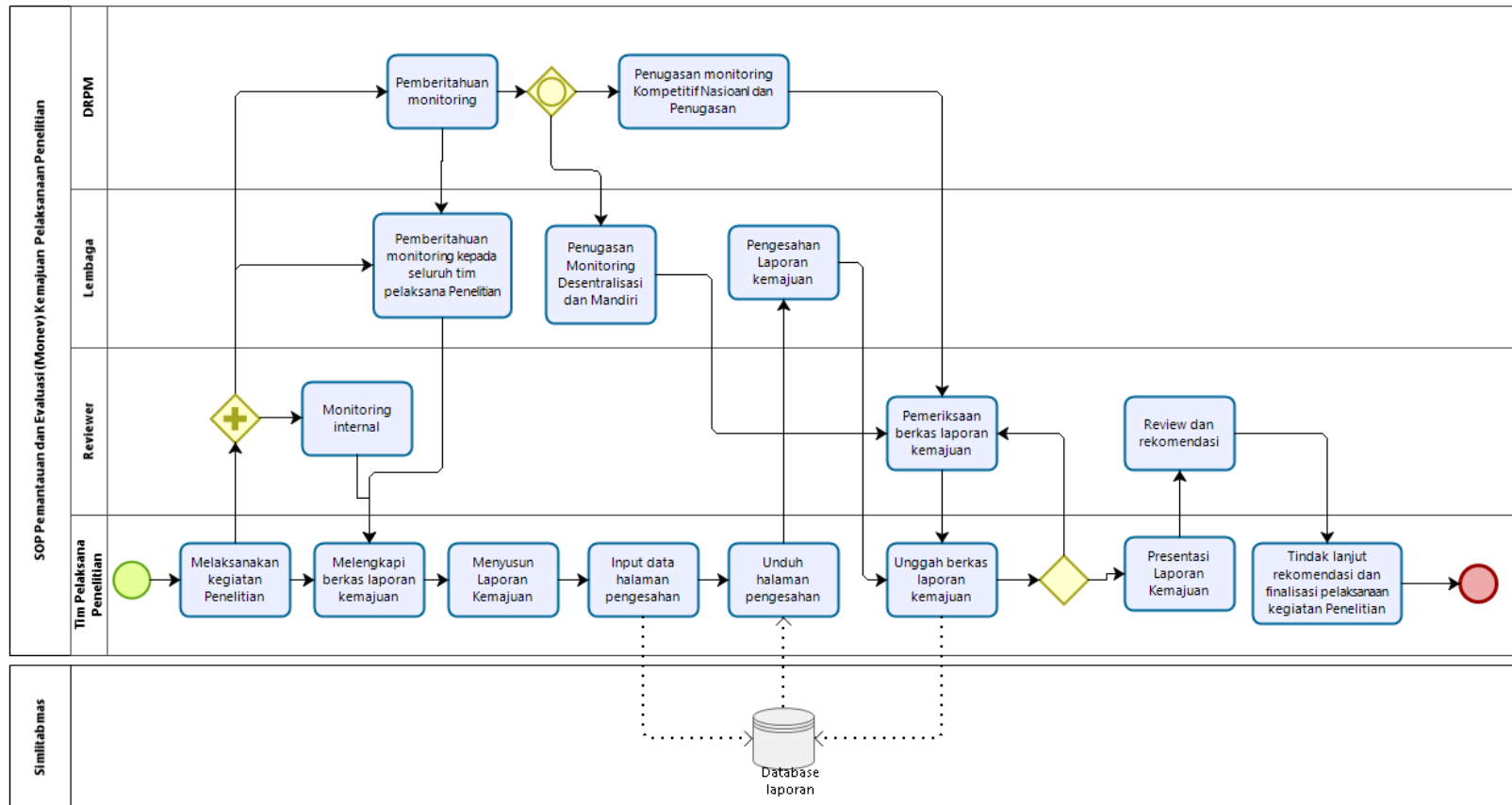



## 103 SOP Operasional Mobil Pintar

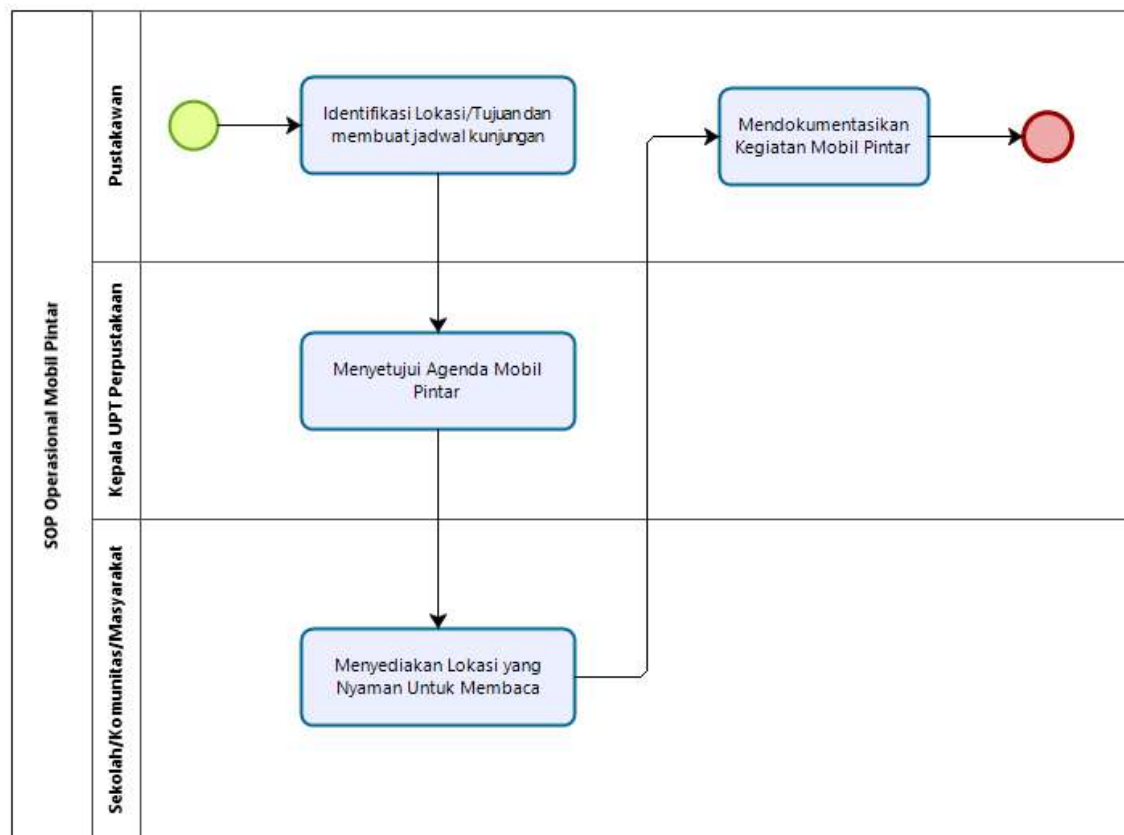



## 104 SOP Pegusulan Pensiun

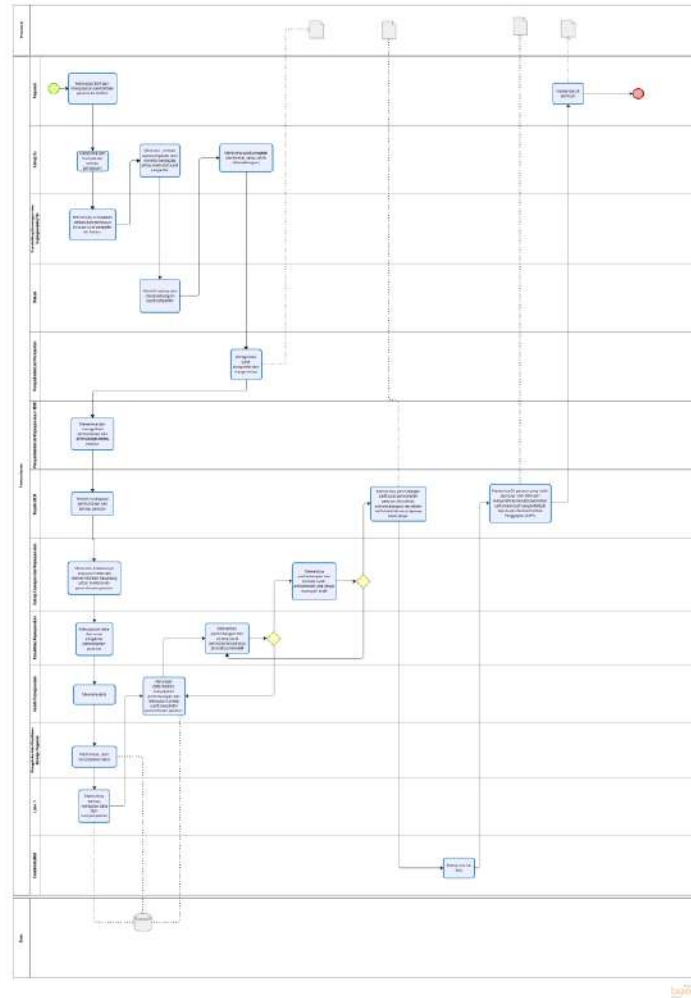



## 105 SOP Pelaksanaan Pengganti Ijazah

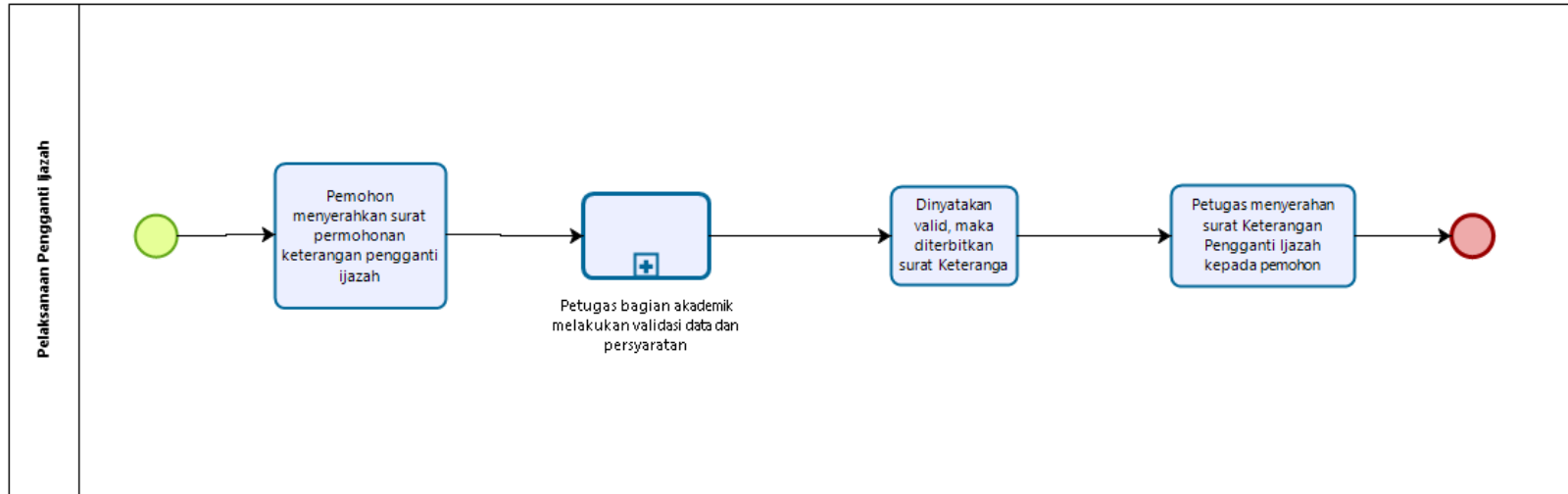



# 106 SOP Pelaksanaan Abdimas Skema Kompetitif Nasional Desentralisasi dan Penugasan

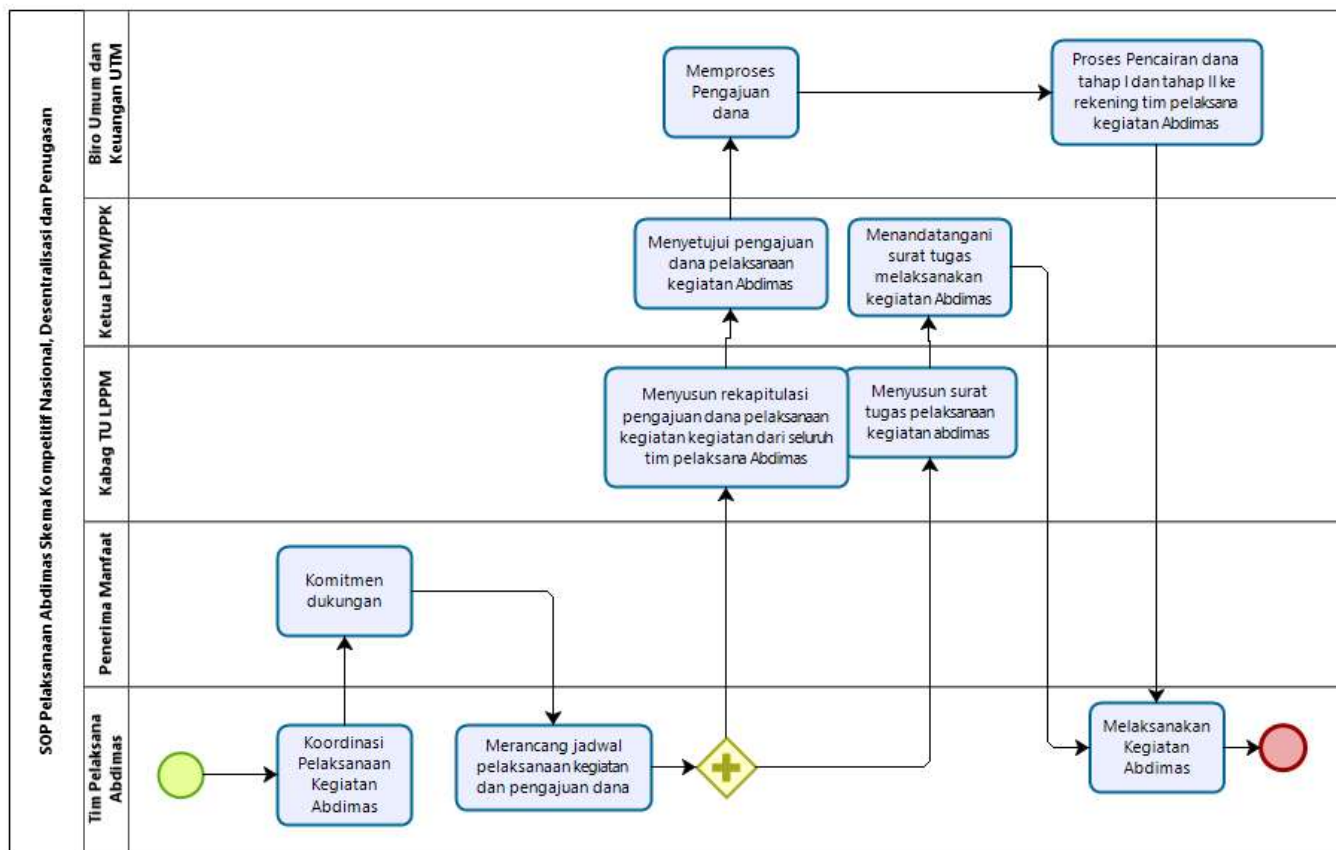

Powered by  
**bizagi**  
Modeler



# 107 SOP Pelaksanaan Penelitian Dasar, Terapan, Pengembangan, Penugasan

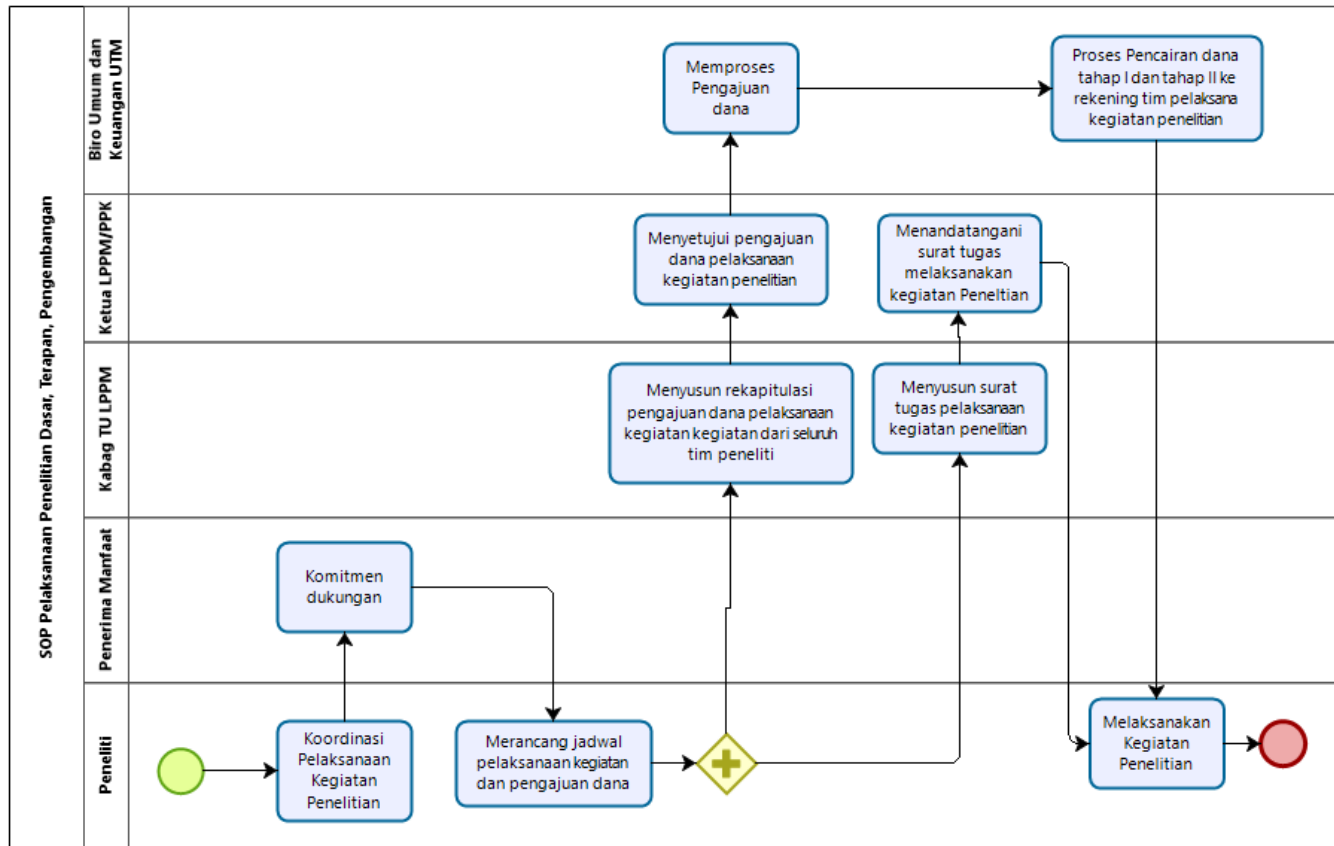



# 108 SOP Pelaksanaan Yudisium

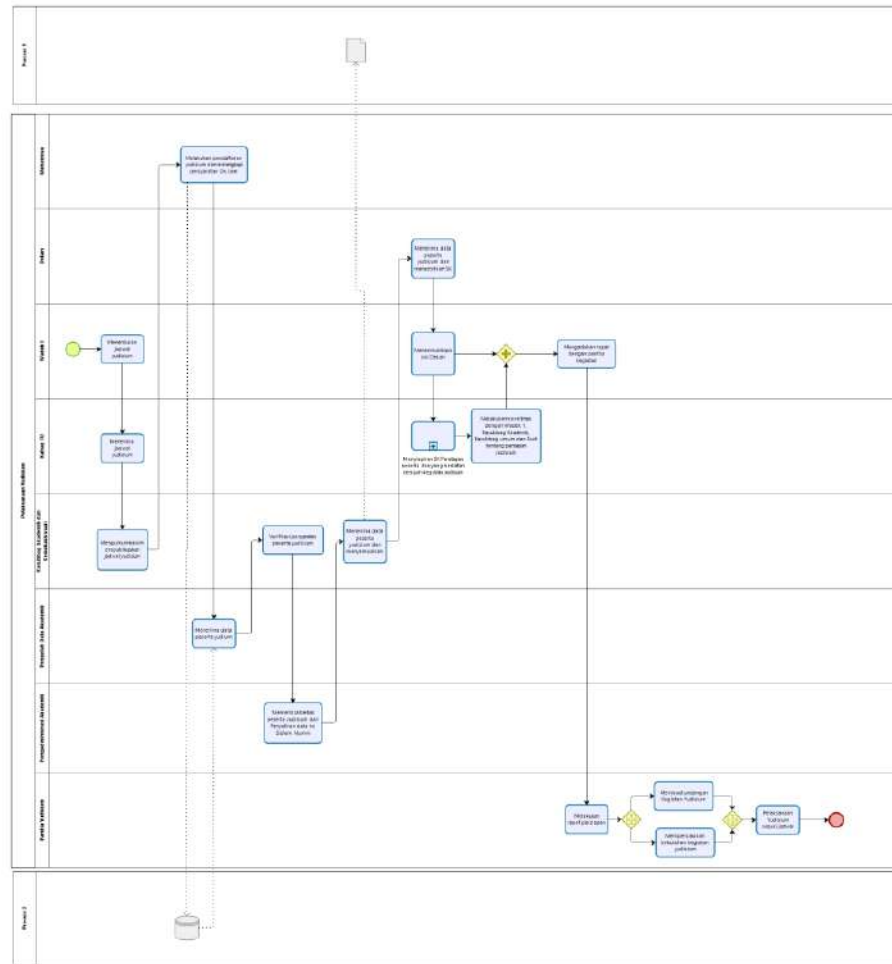



# 109 SOP Pelantikan

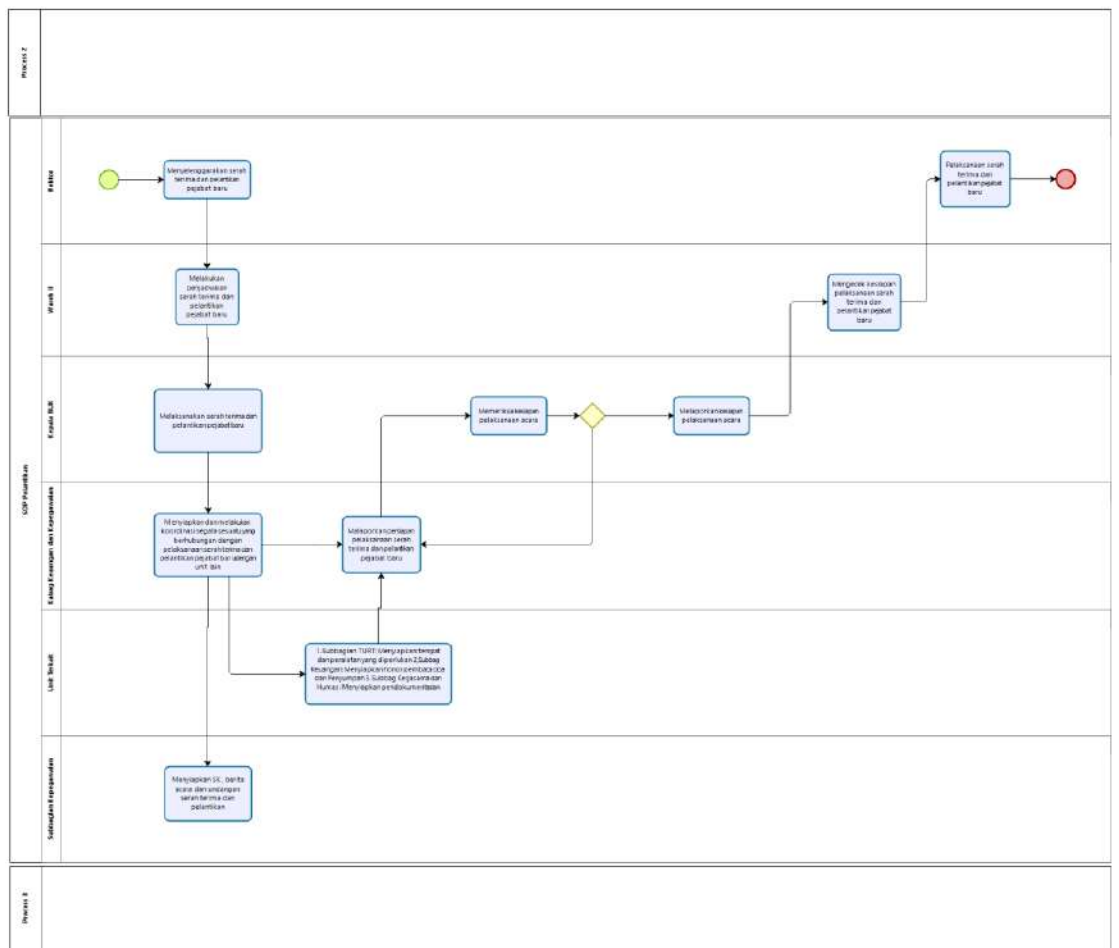





## 110 SOP Pelaporan Hasil Pembelajaran

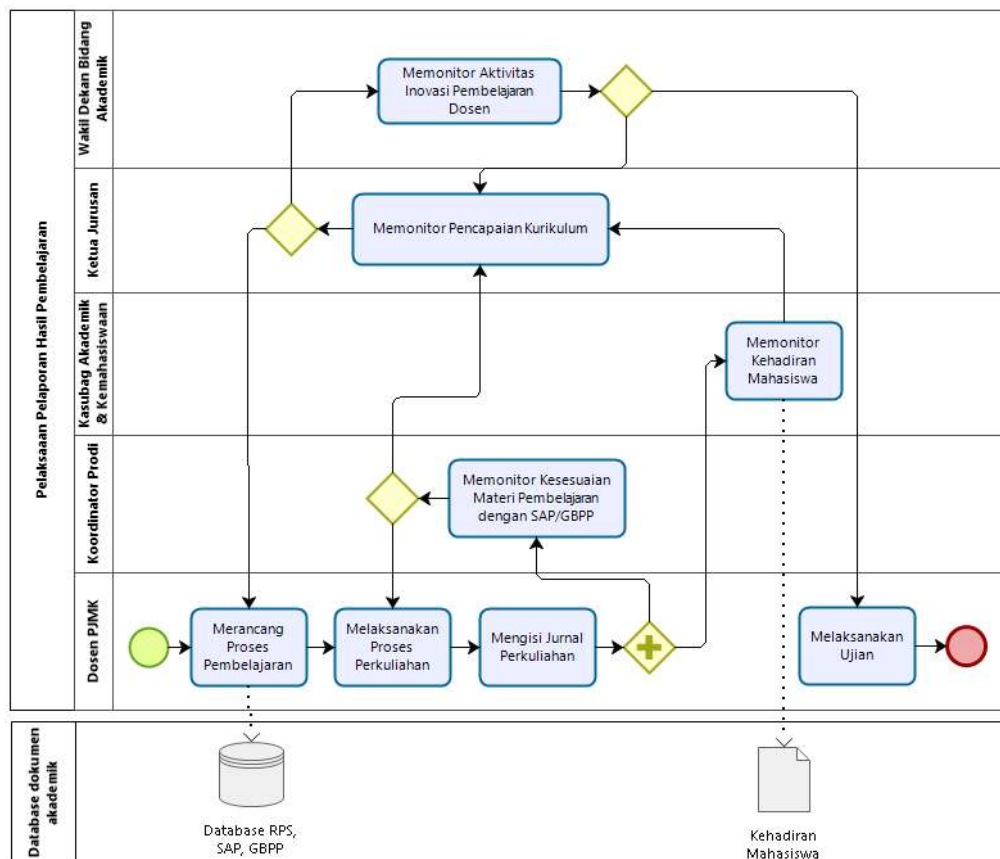



## 111 SOP Pemantauan dan Evaluasi Kemajuan Pelaksanaan abdimas

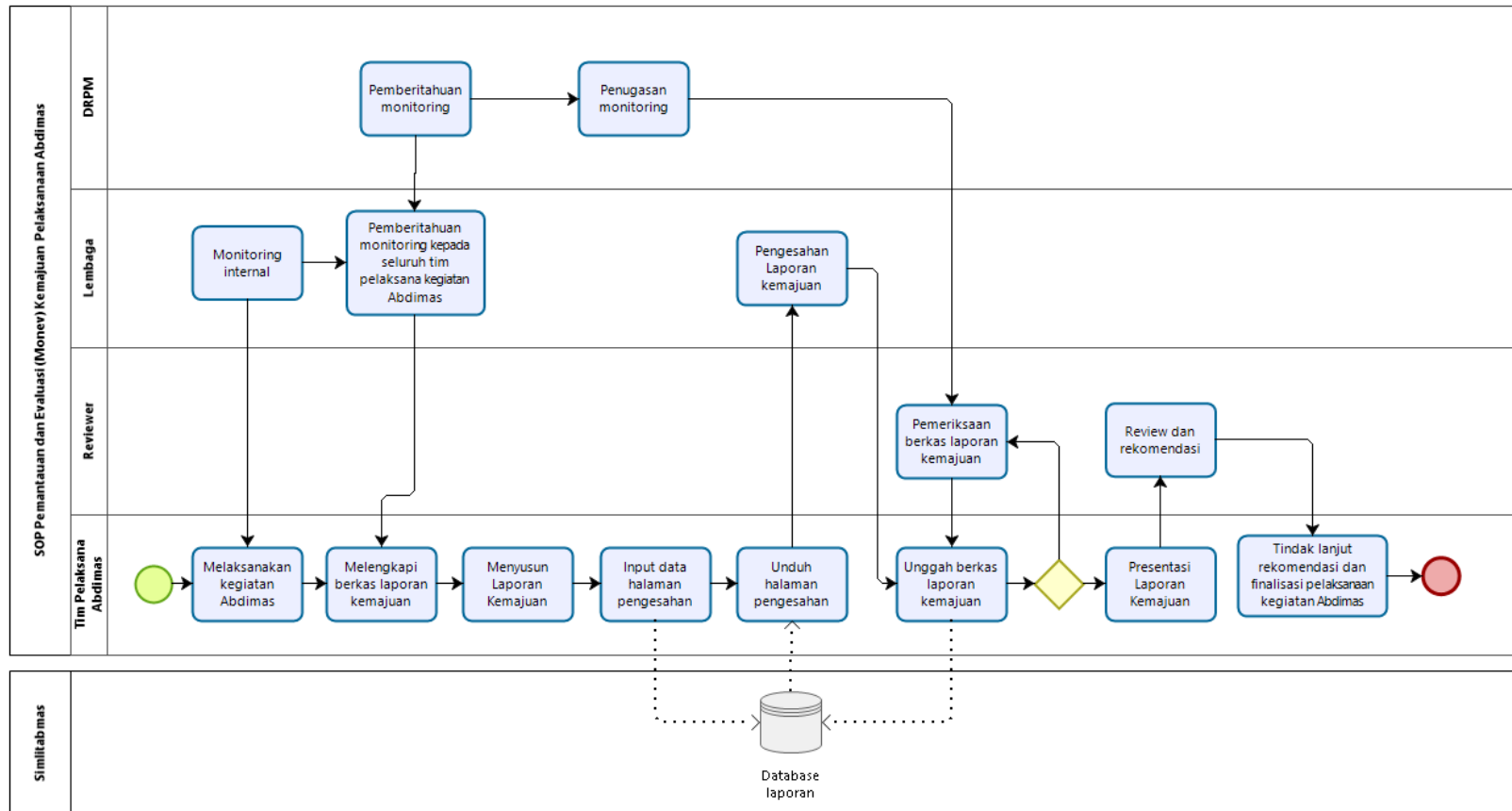



## 112 SOP Pembahasan RKAKL DIPA

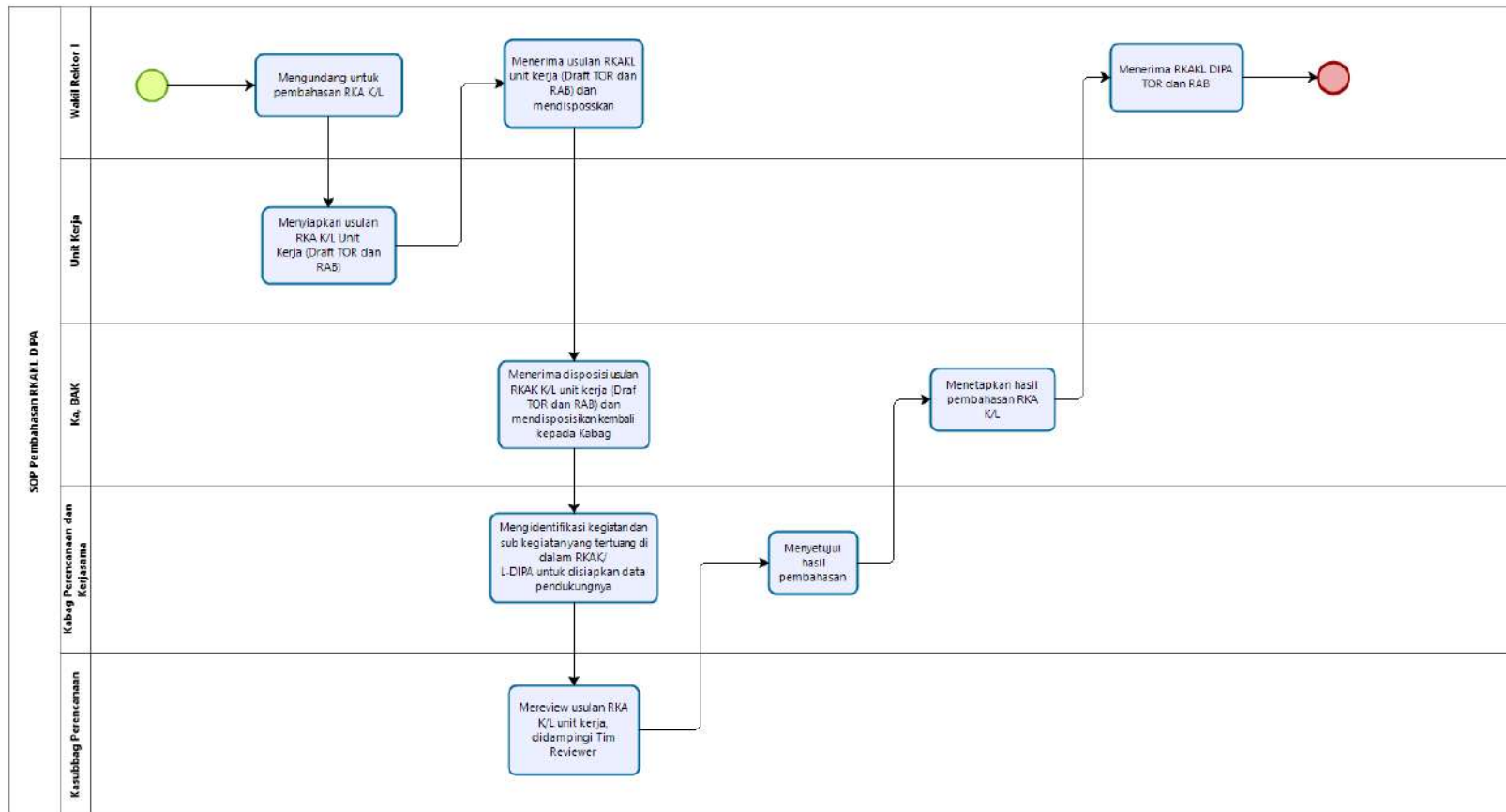



## 113 SOP Pembahasan Tinjauan Manajemen Kurikulum

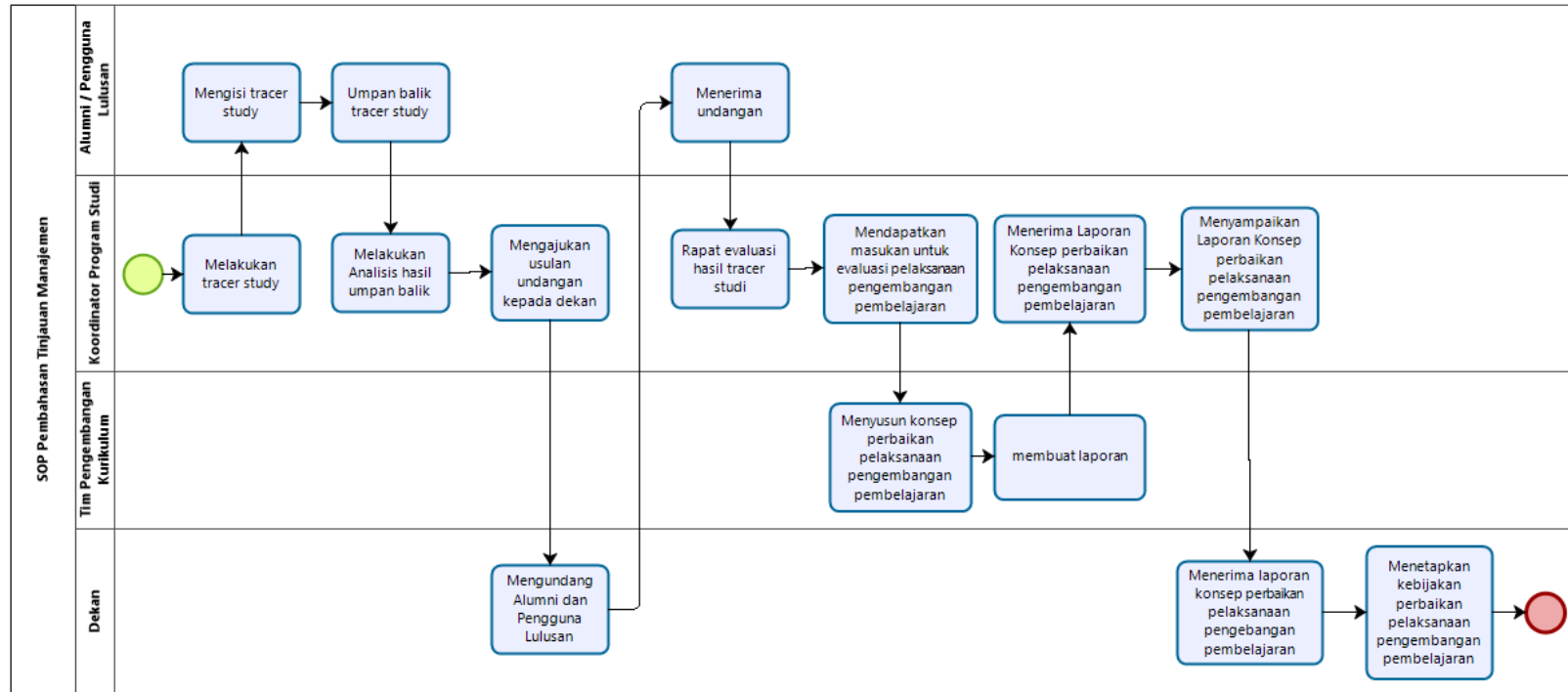



# 114 SOP Pembayaran Gaji PNS

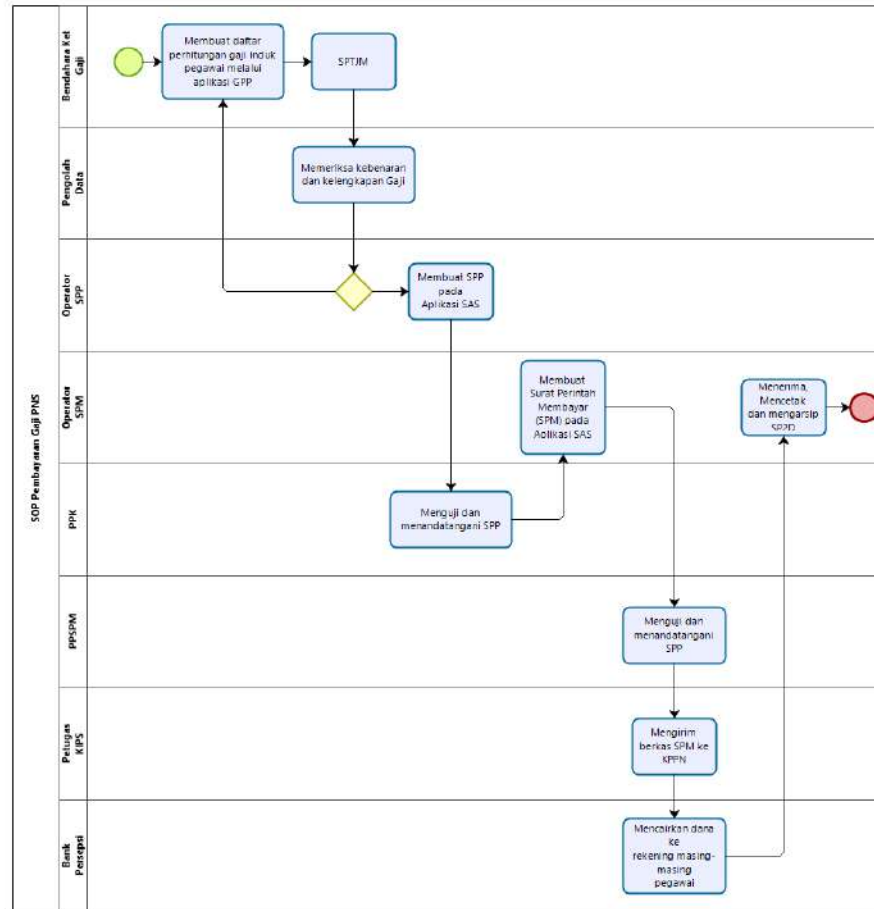



## 115 SOP Pembayaran Kontraktual

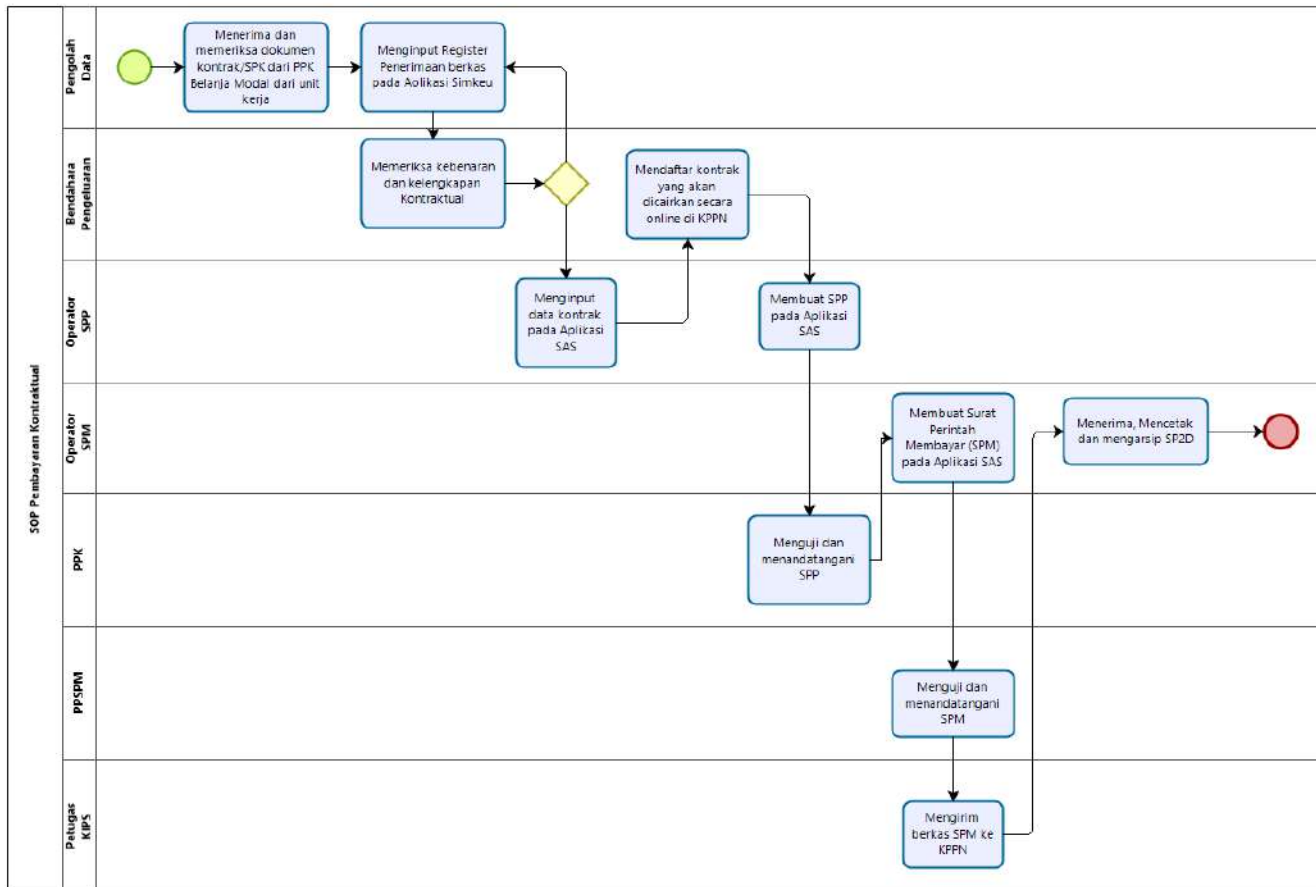



# 116 SOP Pembayaran LS Kontraktual PNBP

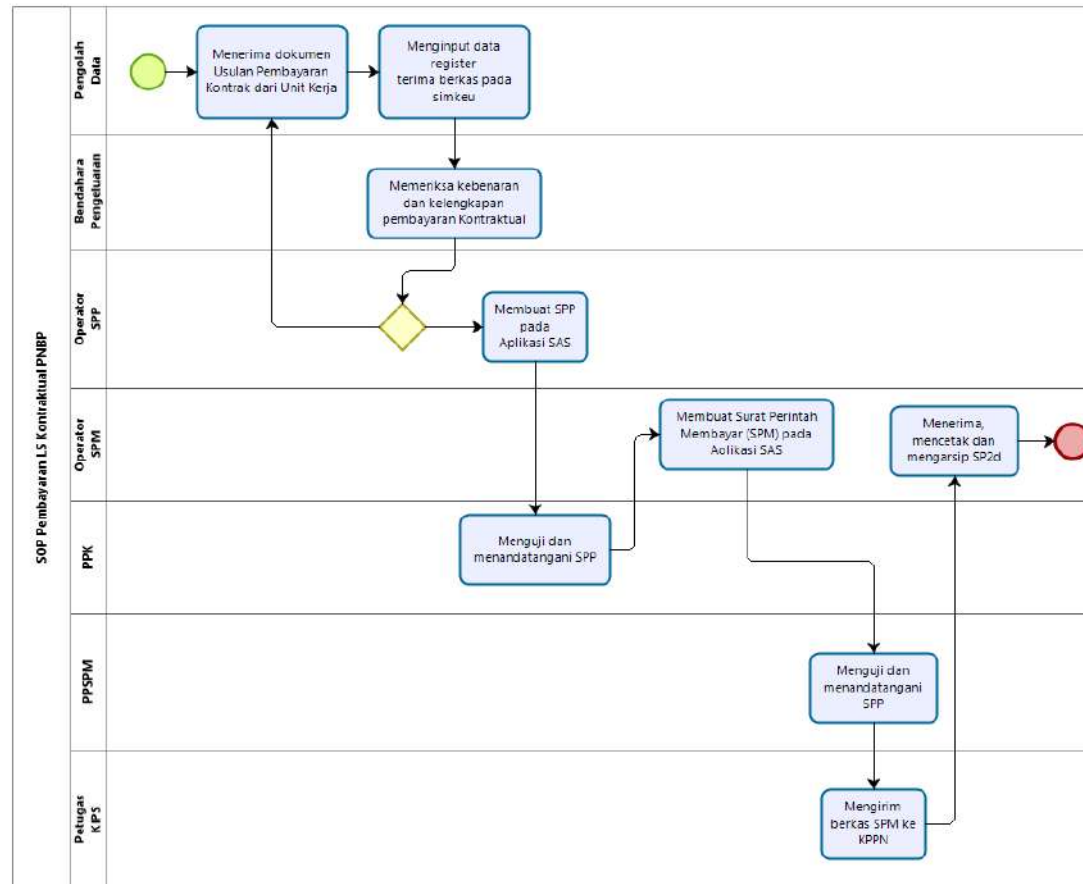



# 117 SOP Pembayaran LS Non Kontraktual Non PNB

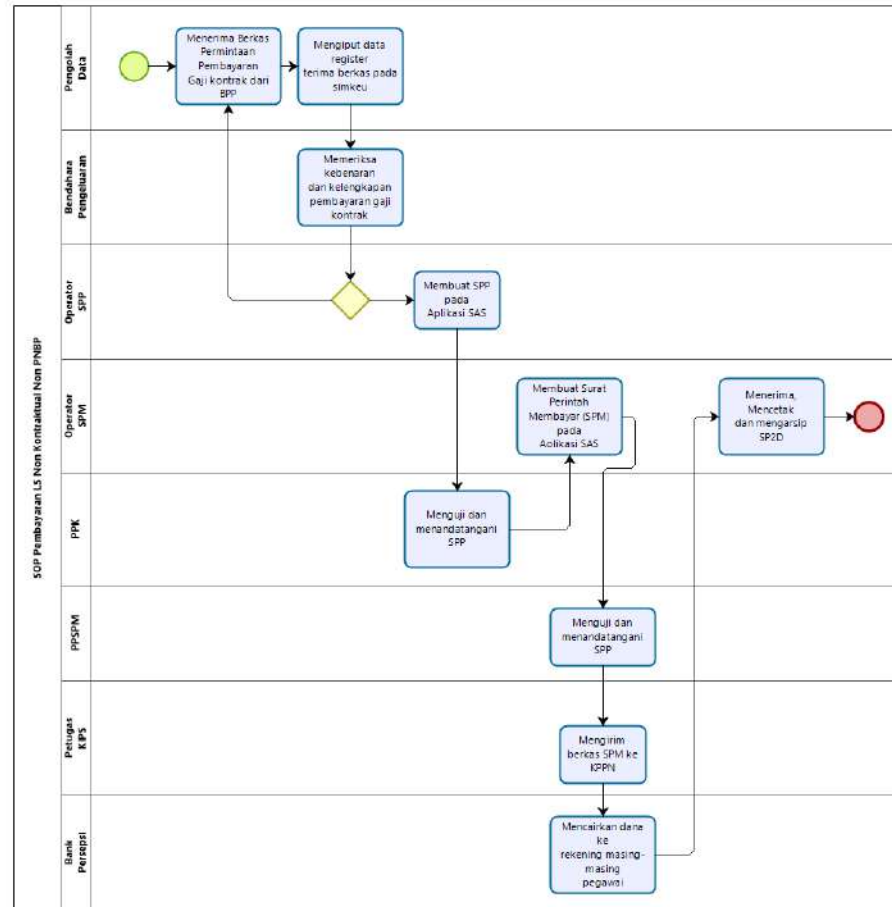





## 118 SOP Pembayaran LS NON Kontraktual PNB

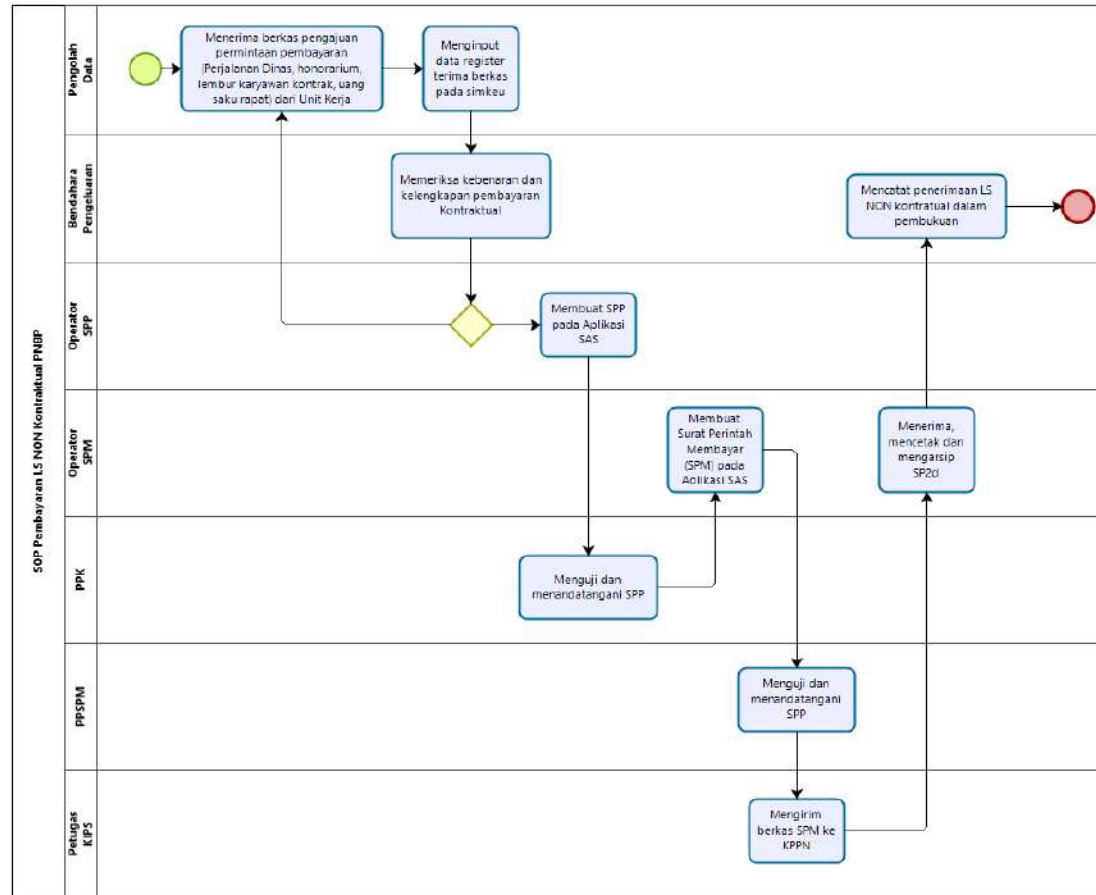



# 119 SOP Pembayaran Tunjangan Kehormatan dan Sertifikasi Dosen NON PNB

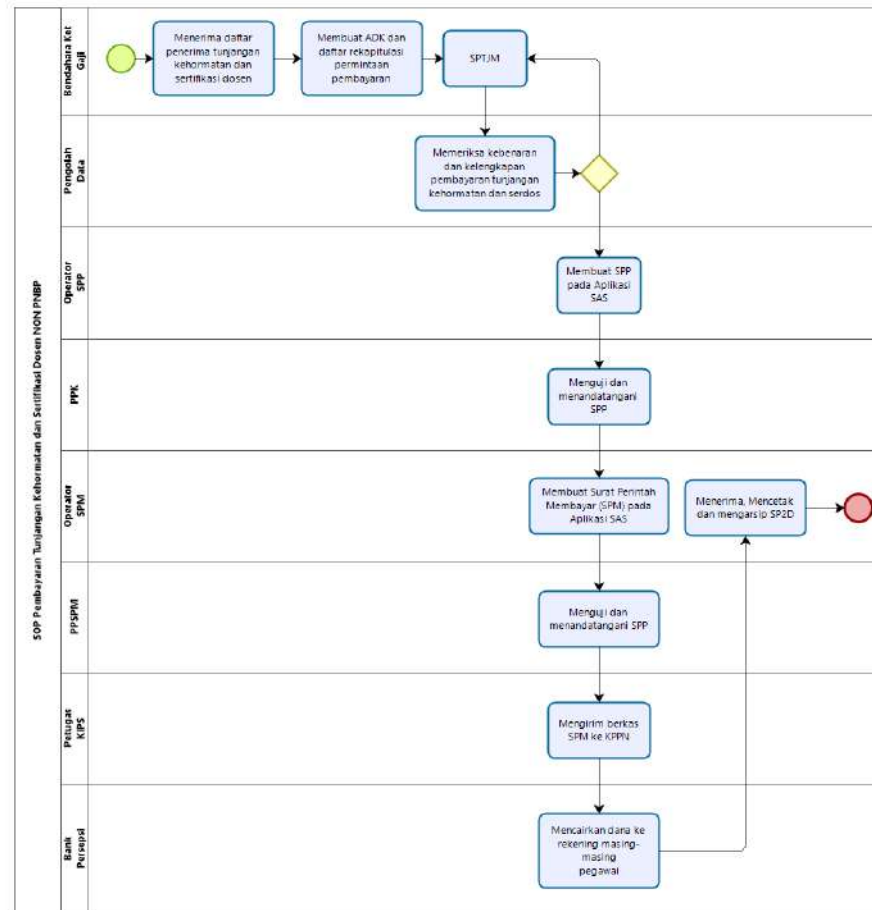



## 120 SOP Pembayaran Uang Lembur Non PNBP

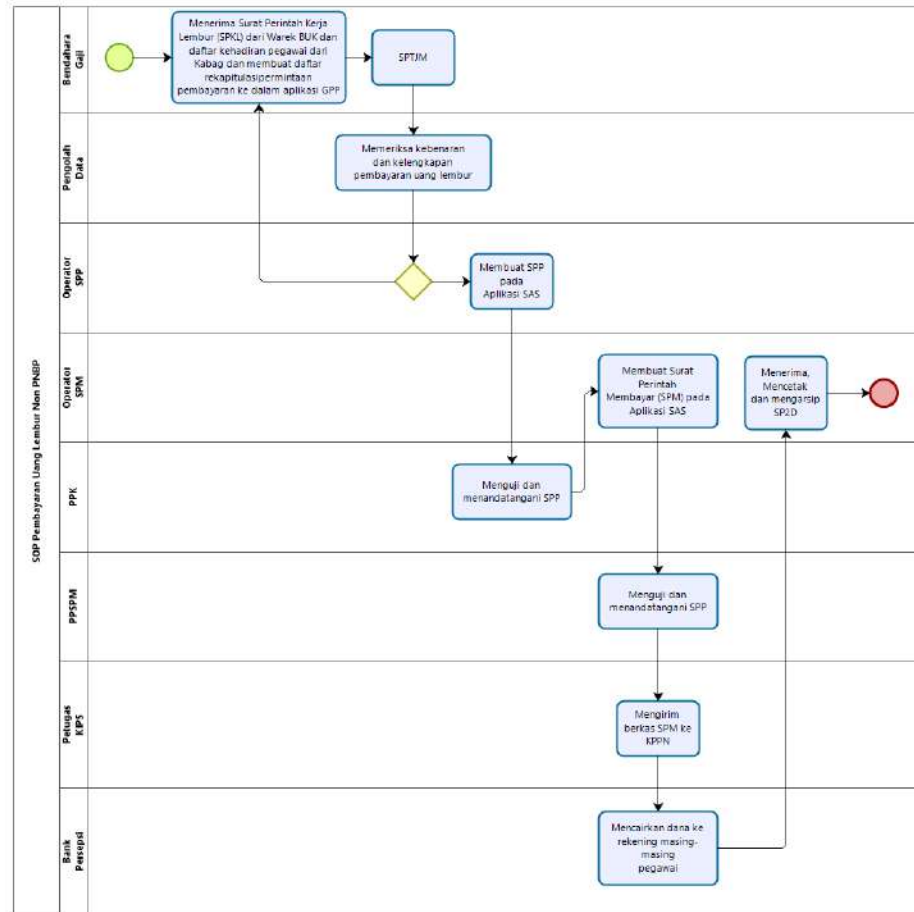



## 121 SOP Pembayaran Uang Makan PNS

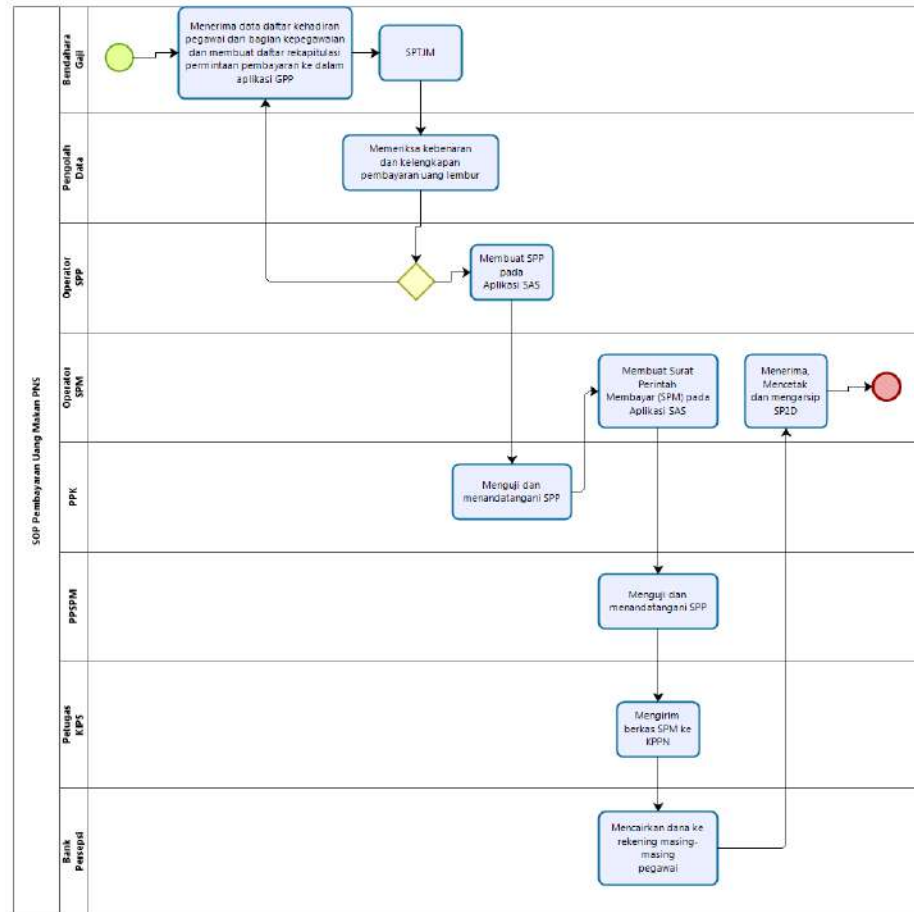



## 122 SOP Pembayaran UKT Terlambat

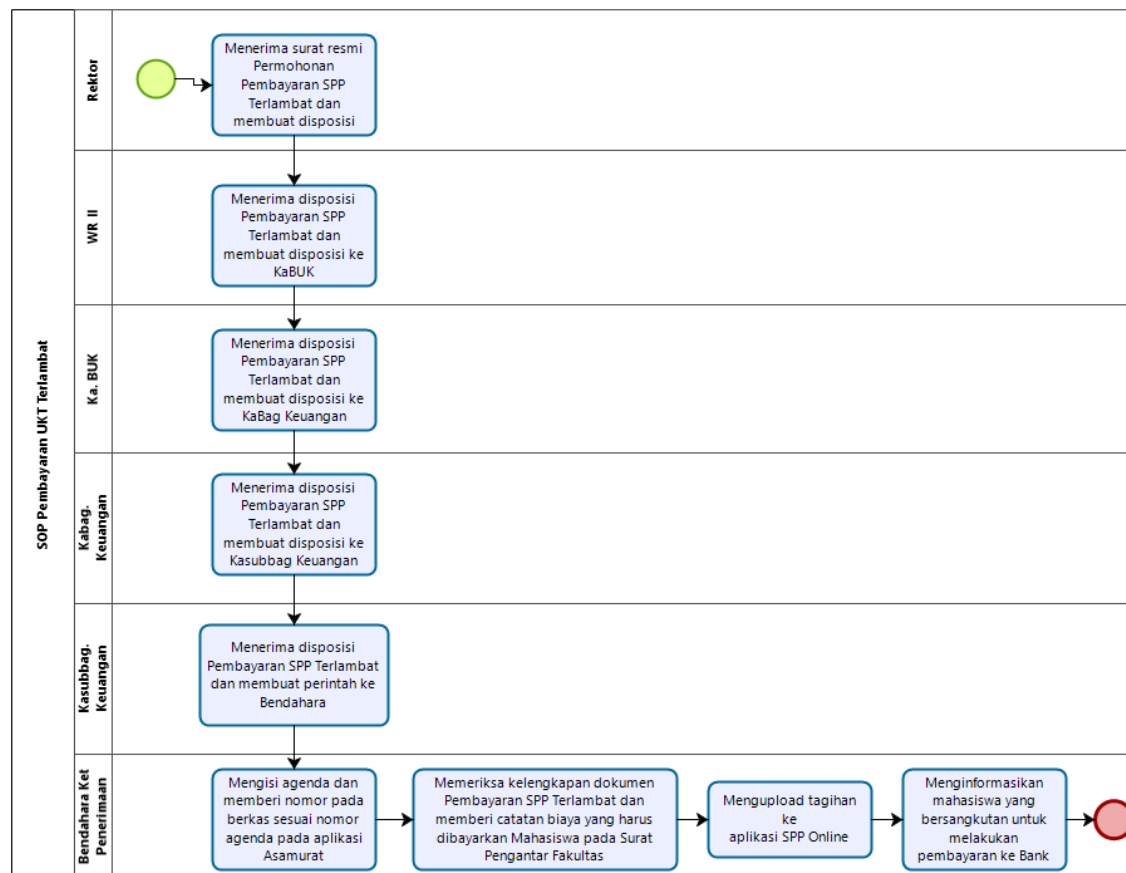



## 123 SOP Pemberkasan Kearsipan

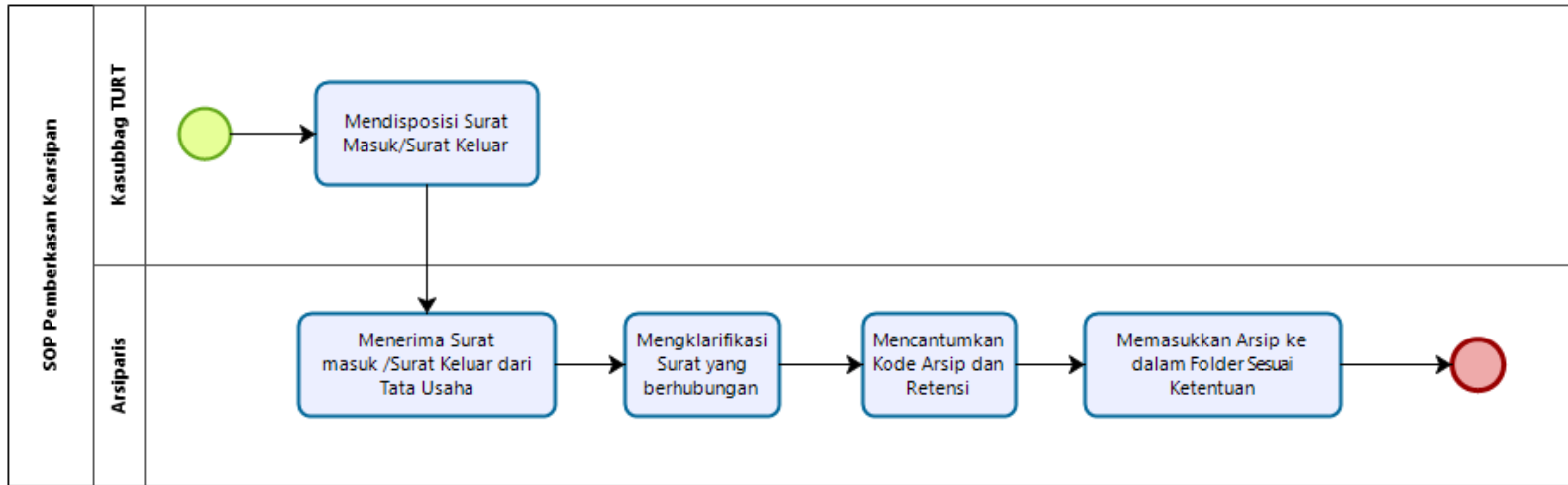



## 124 SOP Pembuatan Kartu Anggota

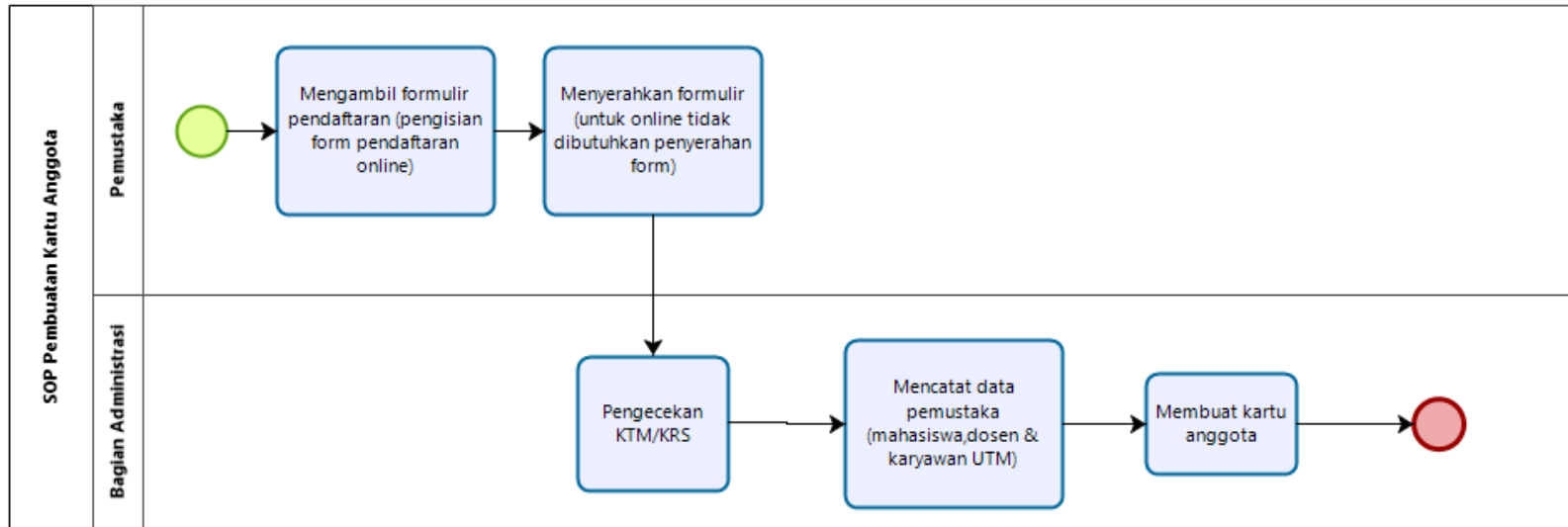



## 125 SOP Pemeriksaan Khusus dan Tindak Lanjut

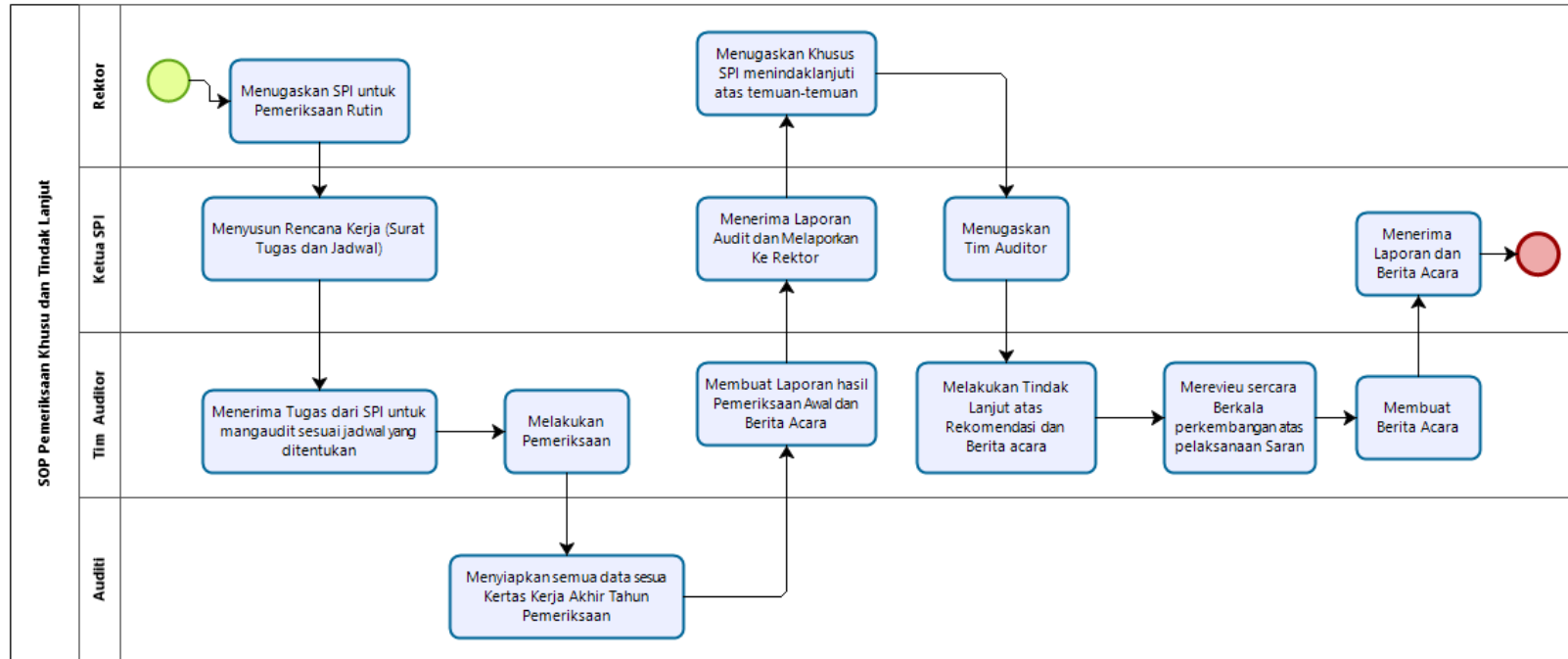





## 126 SOP Pemeriksaan Rutin

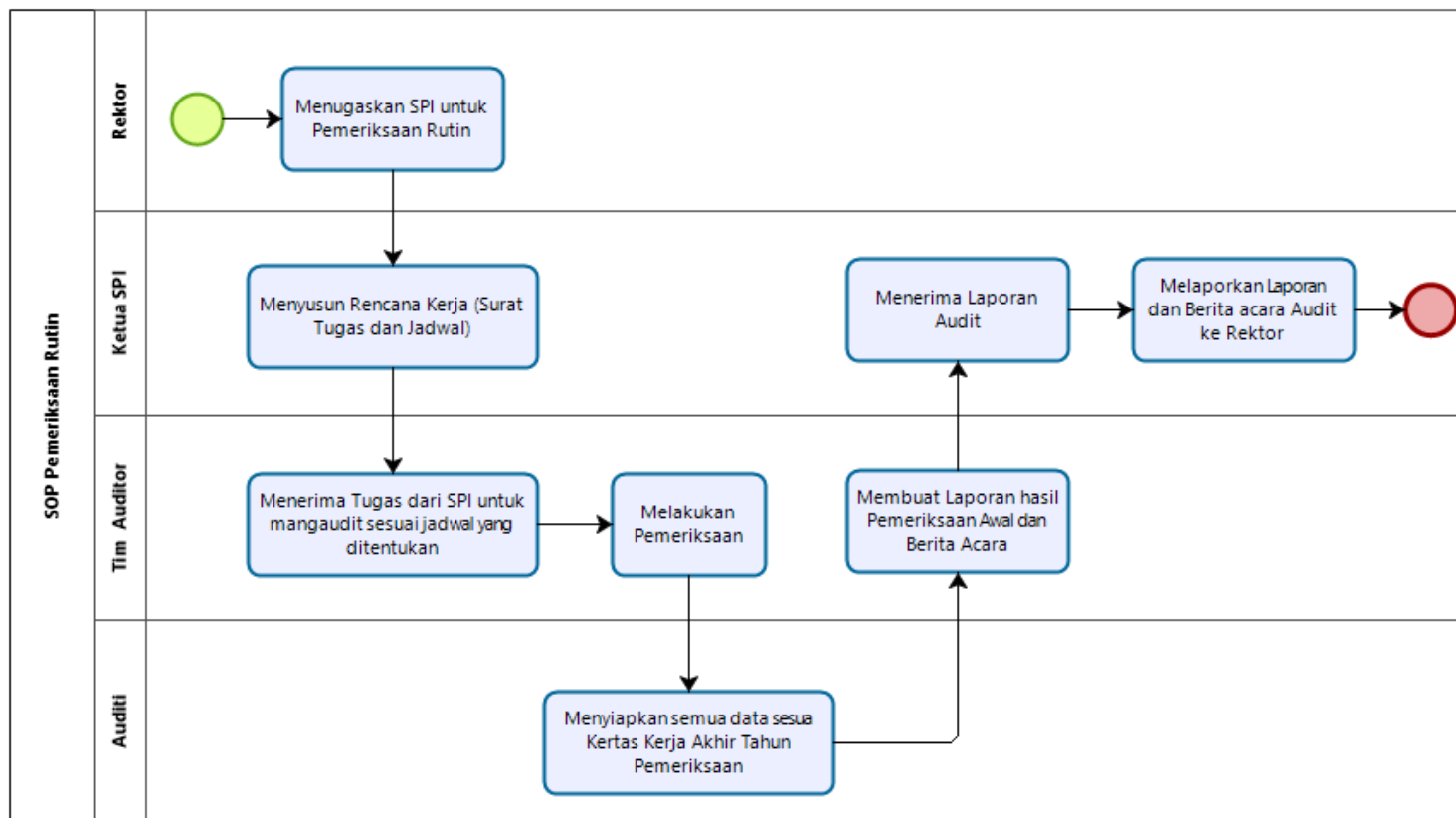



## 127 SOP Pemusnahan Arsip

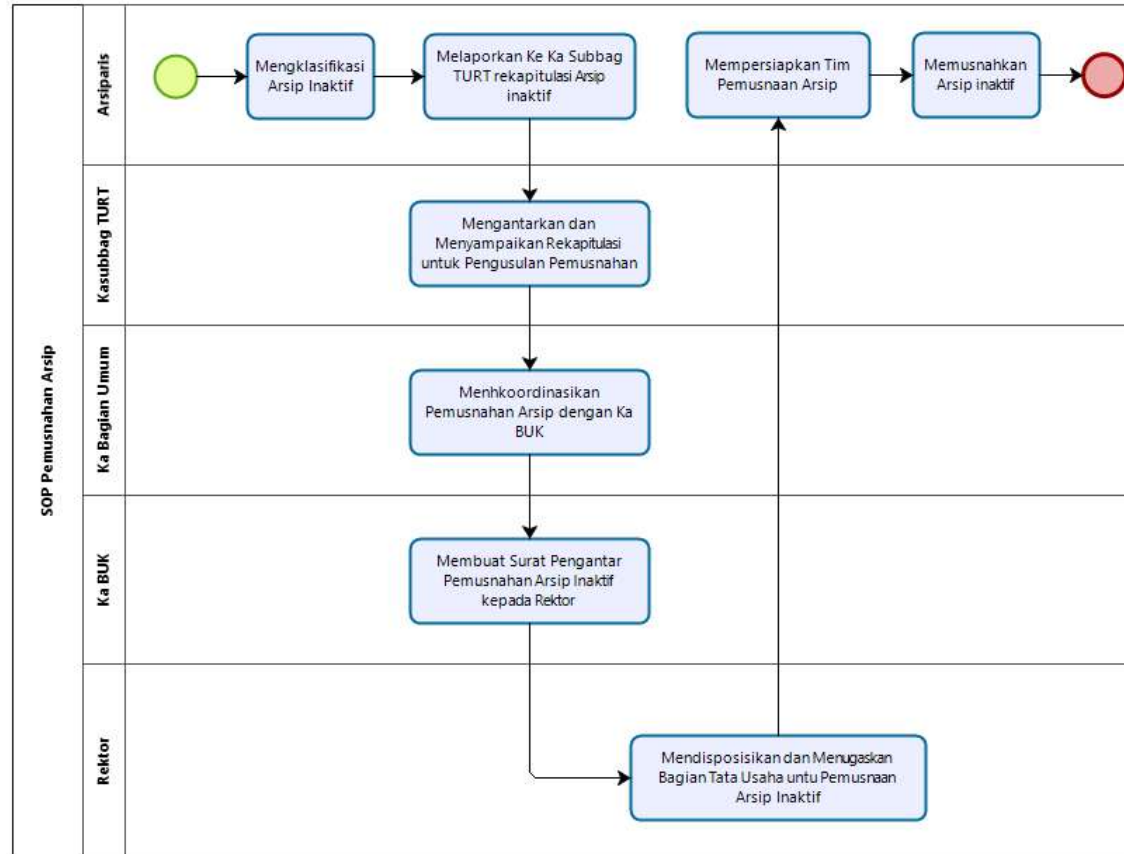



# 128 SOP Pendaftaran Hasil Penelitian Abdimas berpotensi KI ke Pusat HKI LPPM

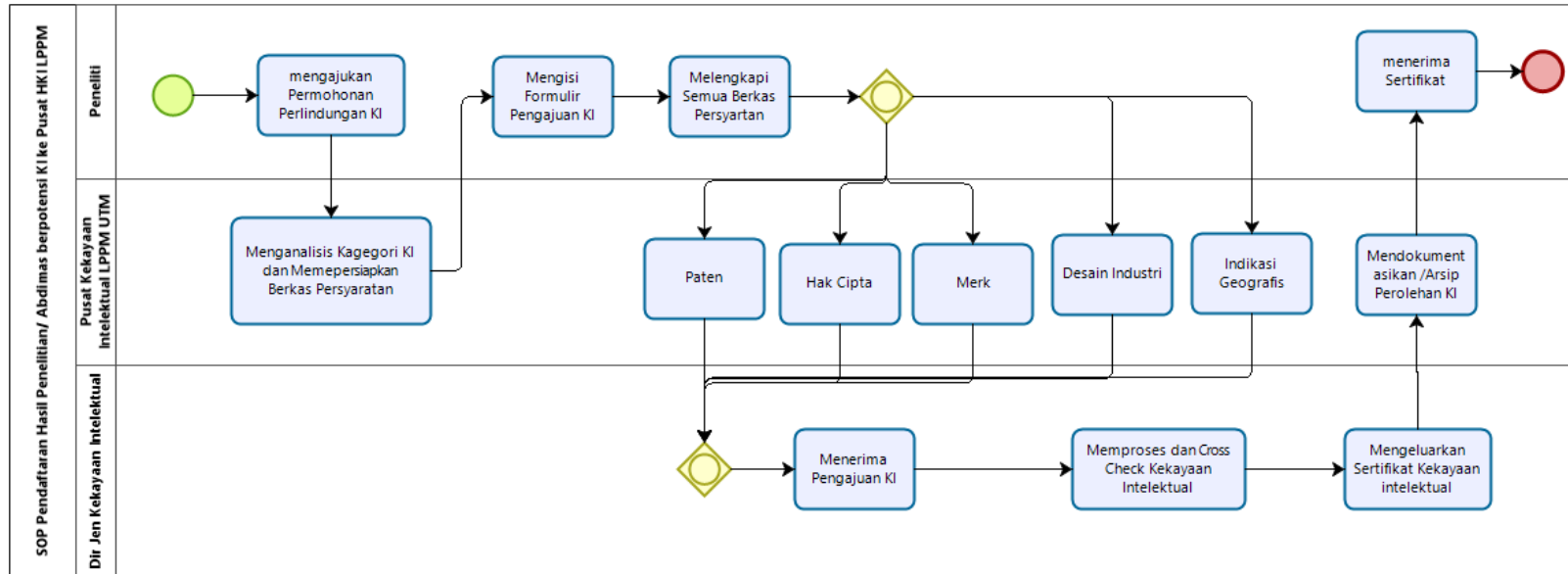



## 129 SOP Penentuan Jadwal Perkuliahan

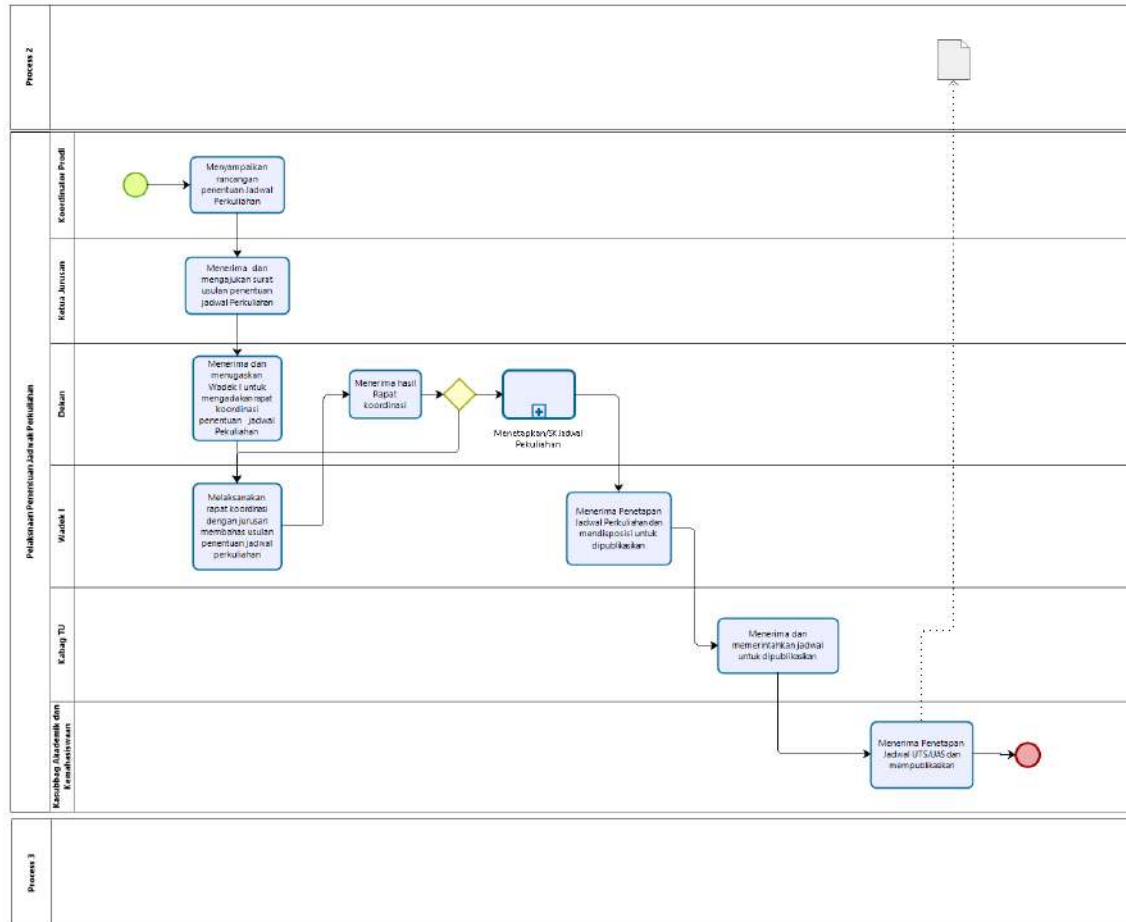



### 130 SOP Penentuan Penerimaan Mahasiswa Melalui Jalur Bidik Misi

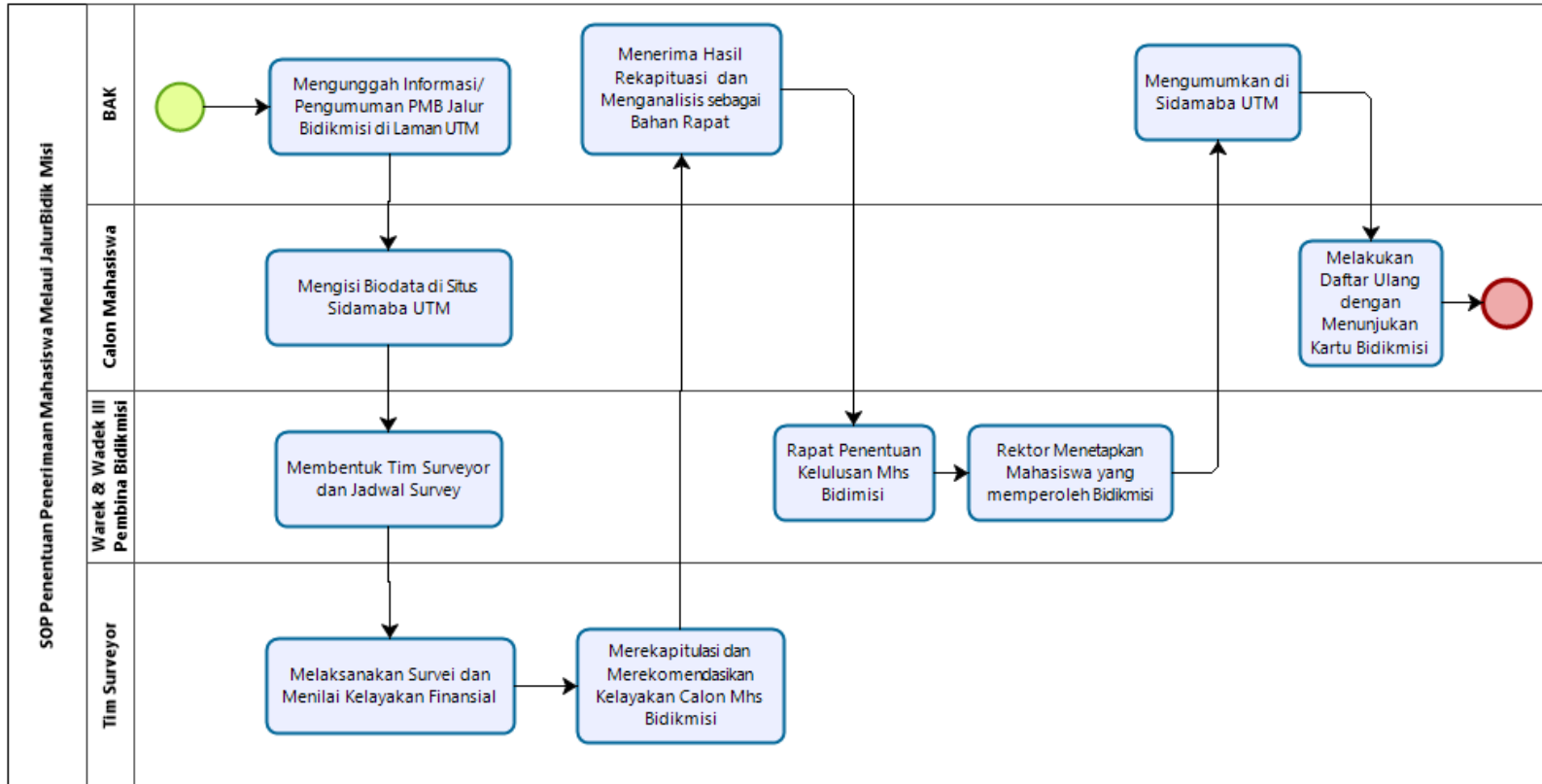



# 131 SOP Penentuan PJMK

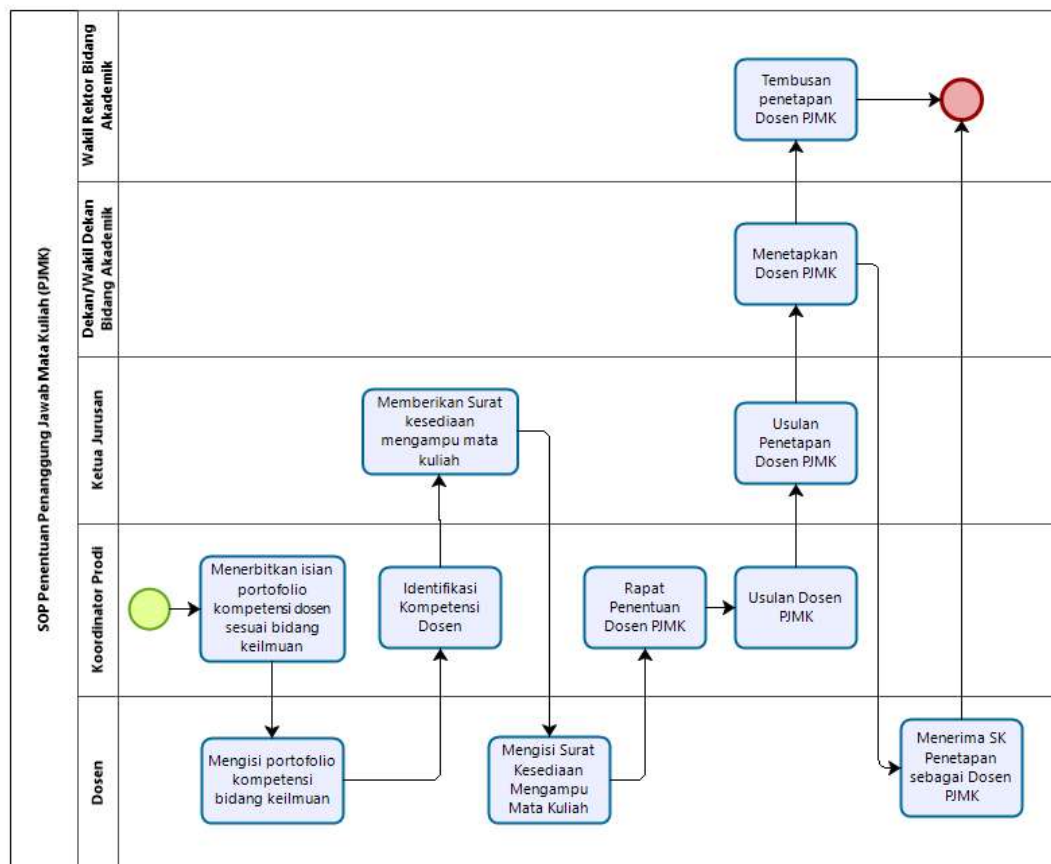



## 132 SOP Penerimaan Mahasiswa Baru Jalur SBMPTN

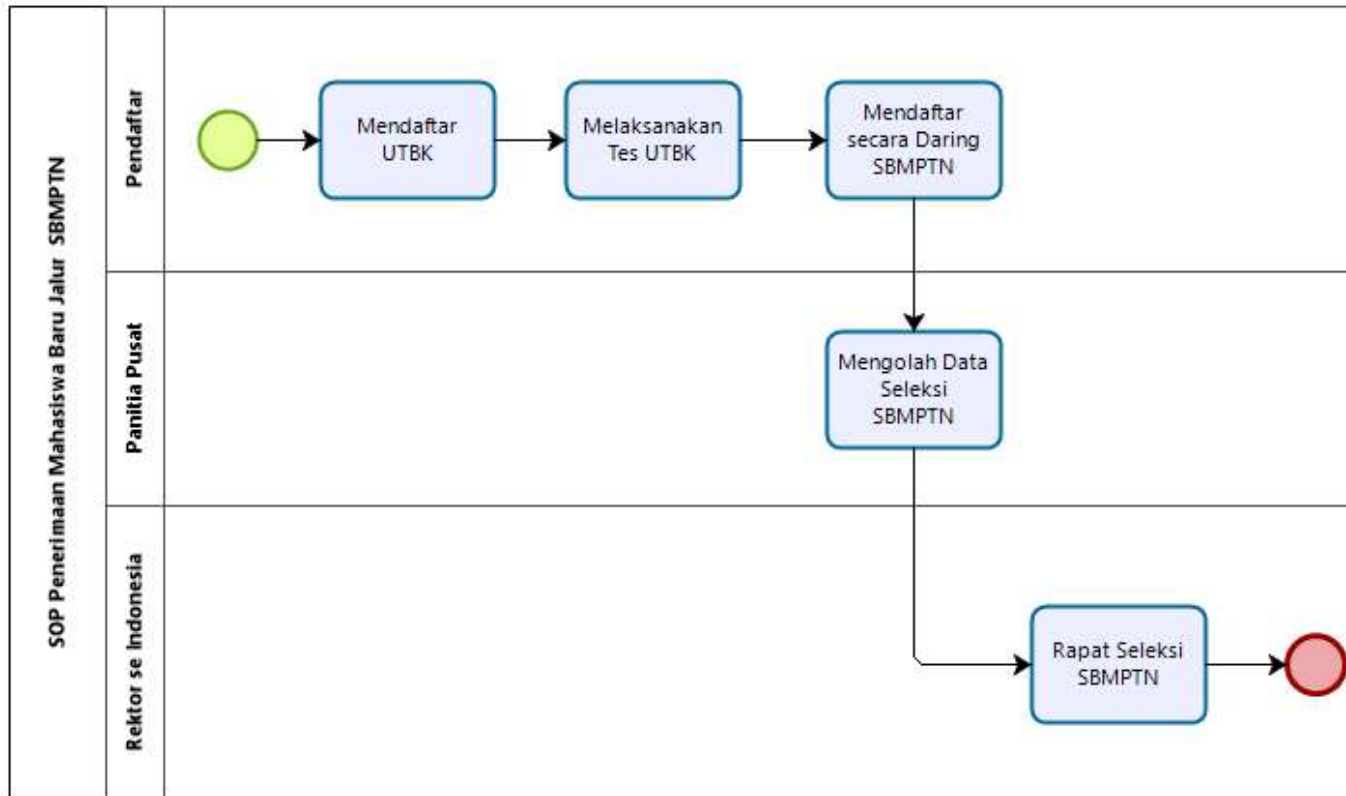



### 133 SOP Penerimaan Mahasiswa Baru Jalur SNMPTN

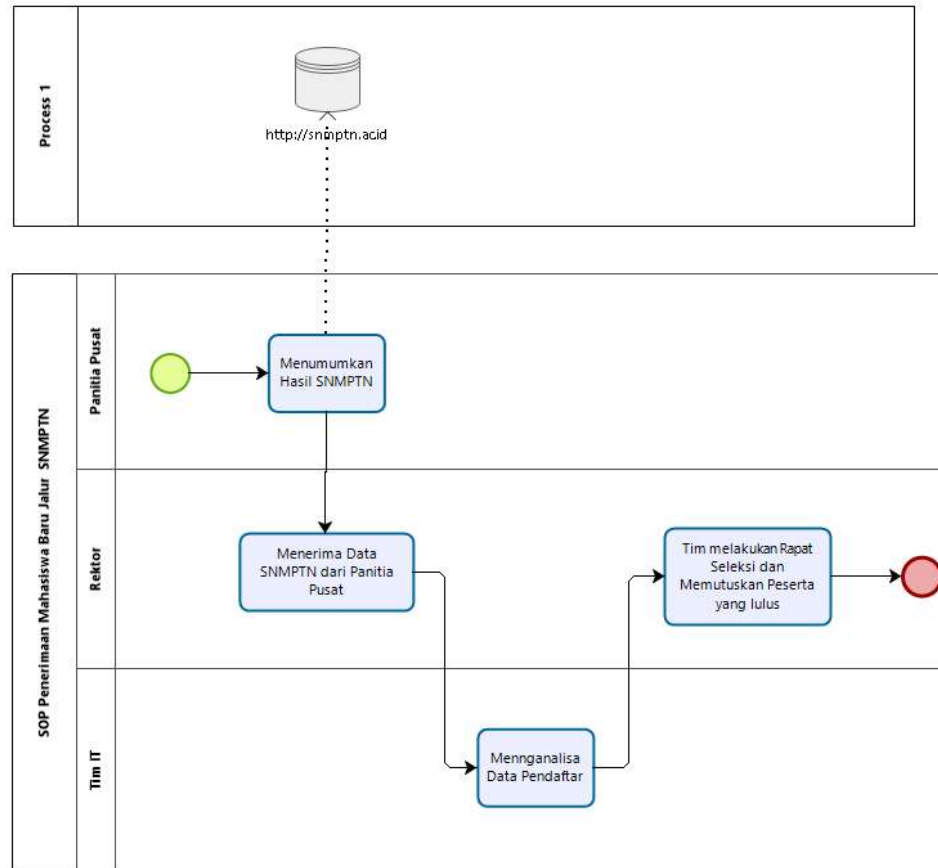







## 135 SOP Penerjemahan

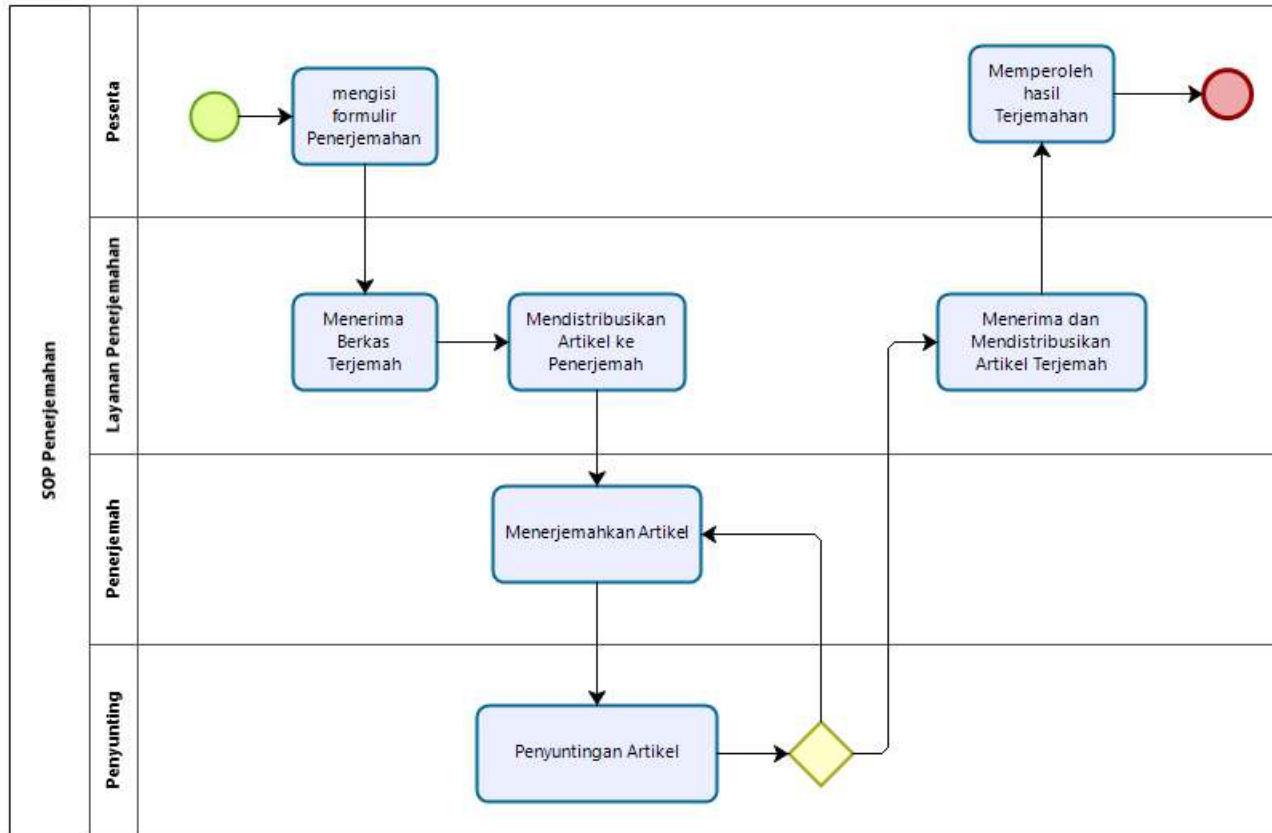



## 136 SOP Penetapan dan Penandatanganan MoU

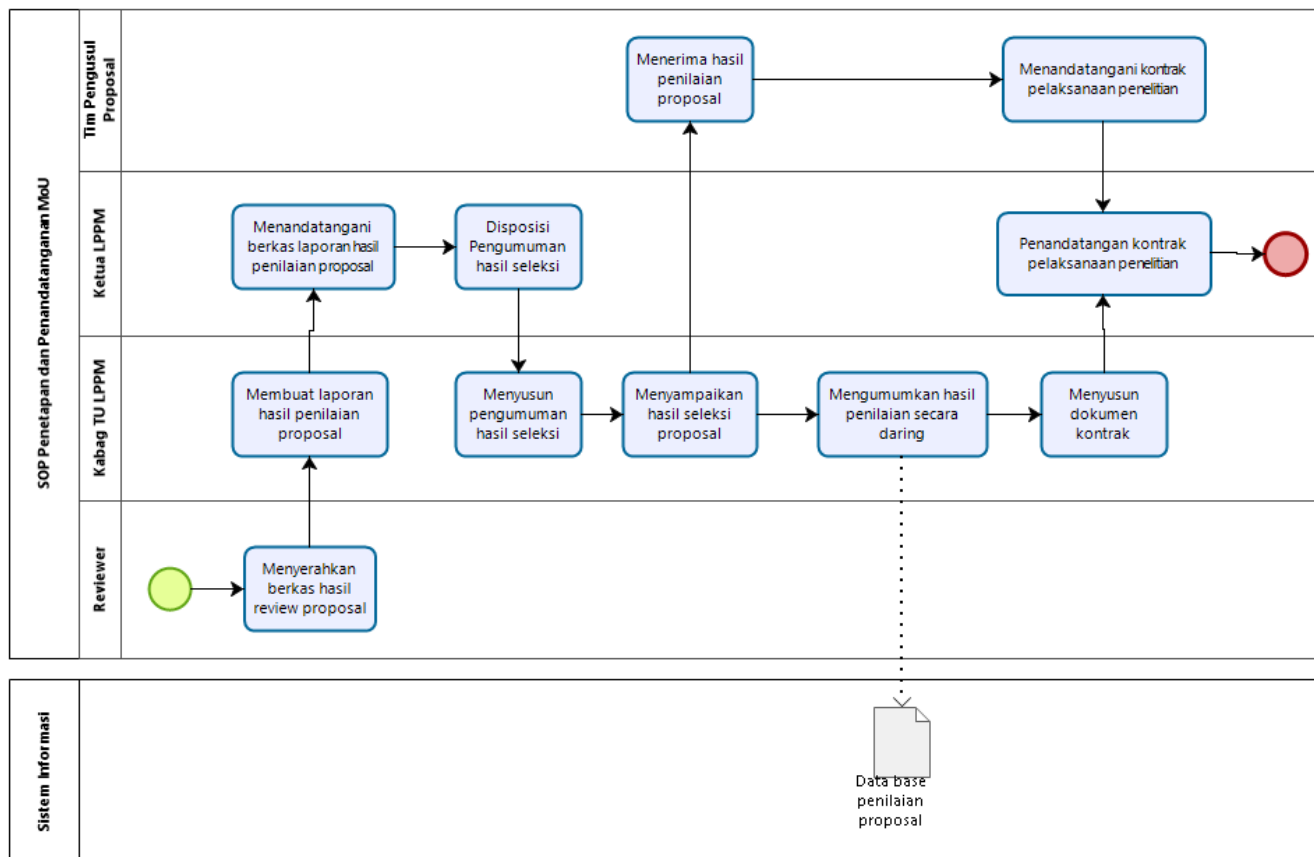



## 137 SOP Penetapan dan Penugasan Abdimas

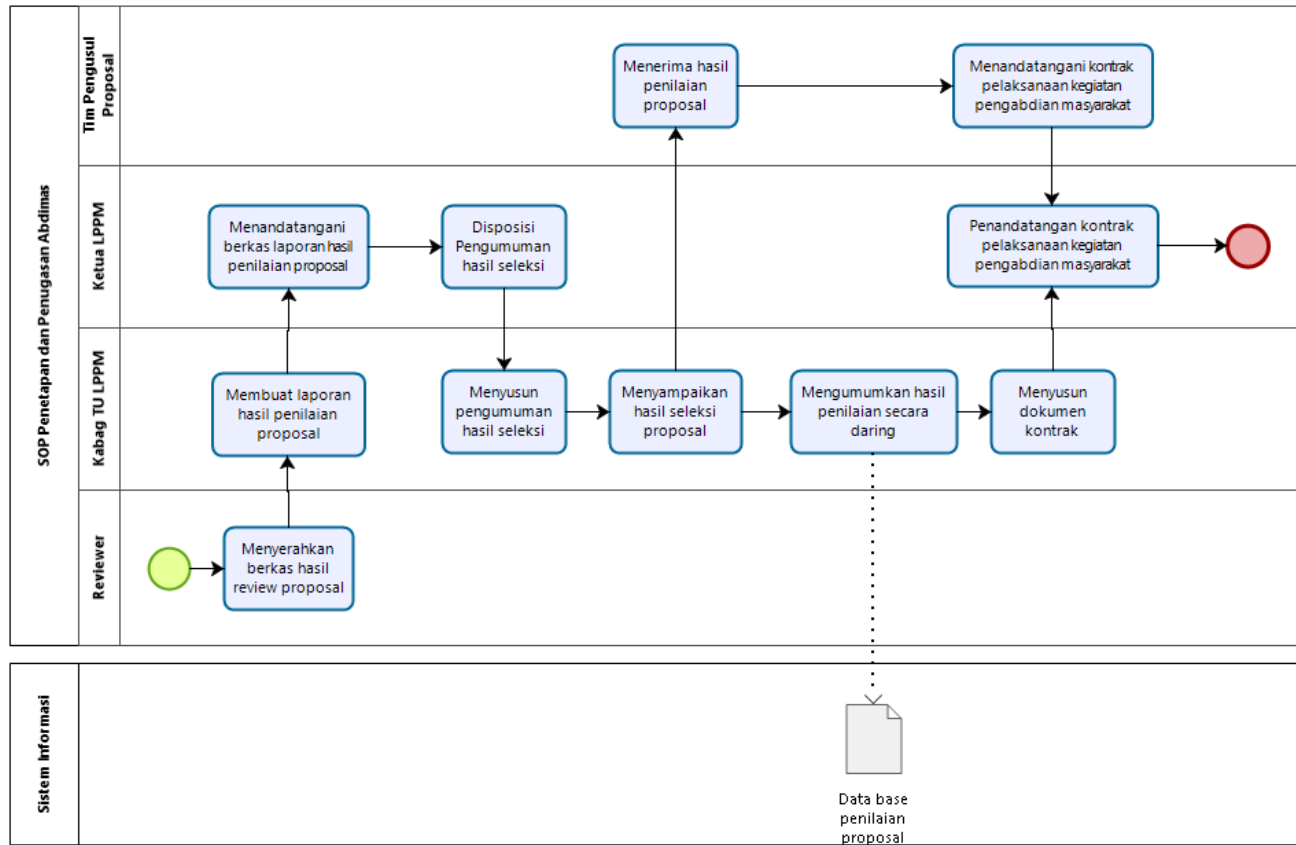



## 138 SOP Penetapan Pagu Mahasiswa Baru

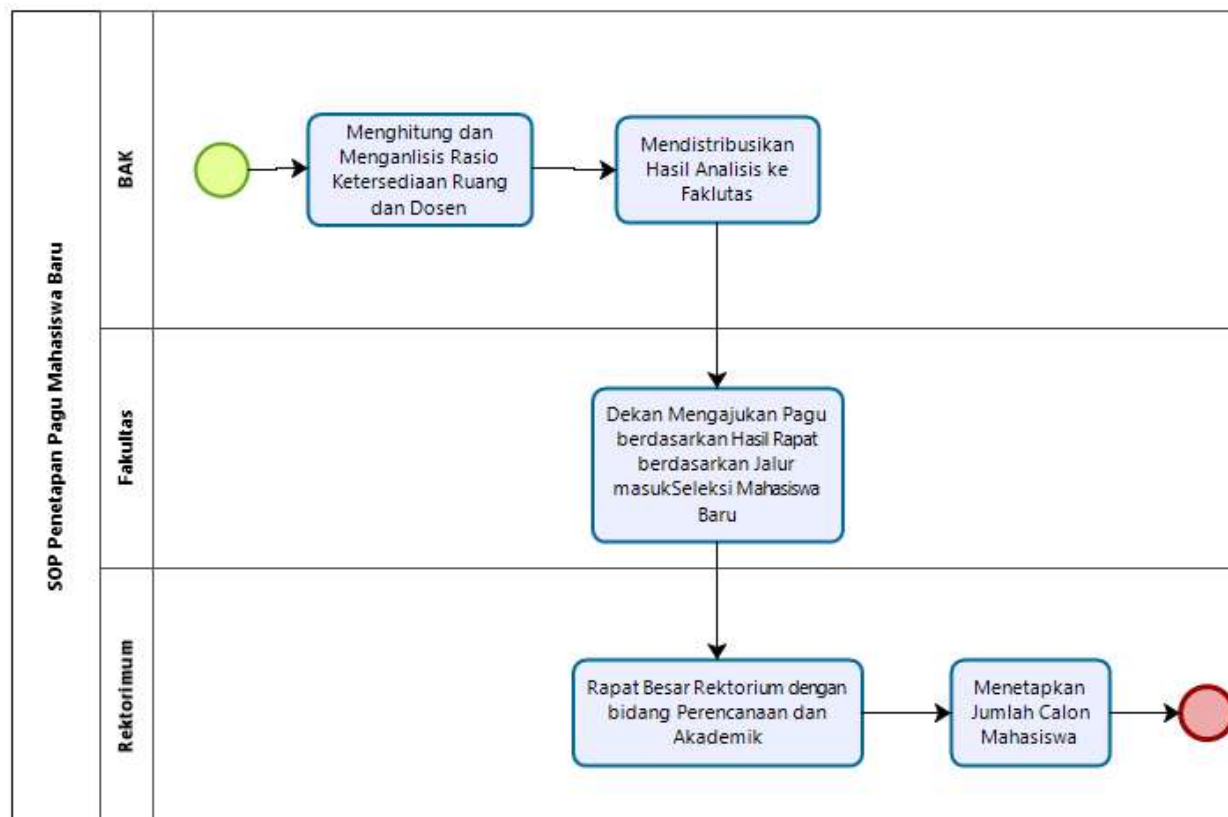



# 139 SOP Pengaduan Jaringan Intranet dan Internet

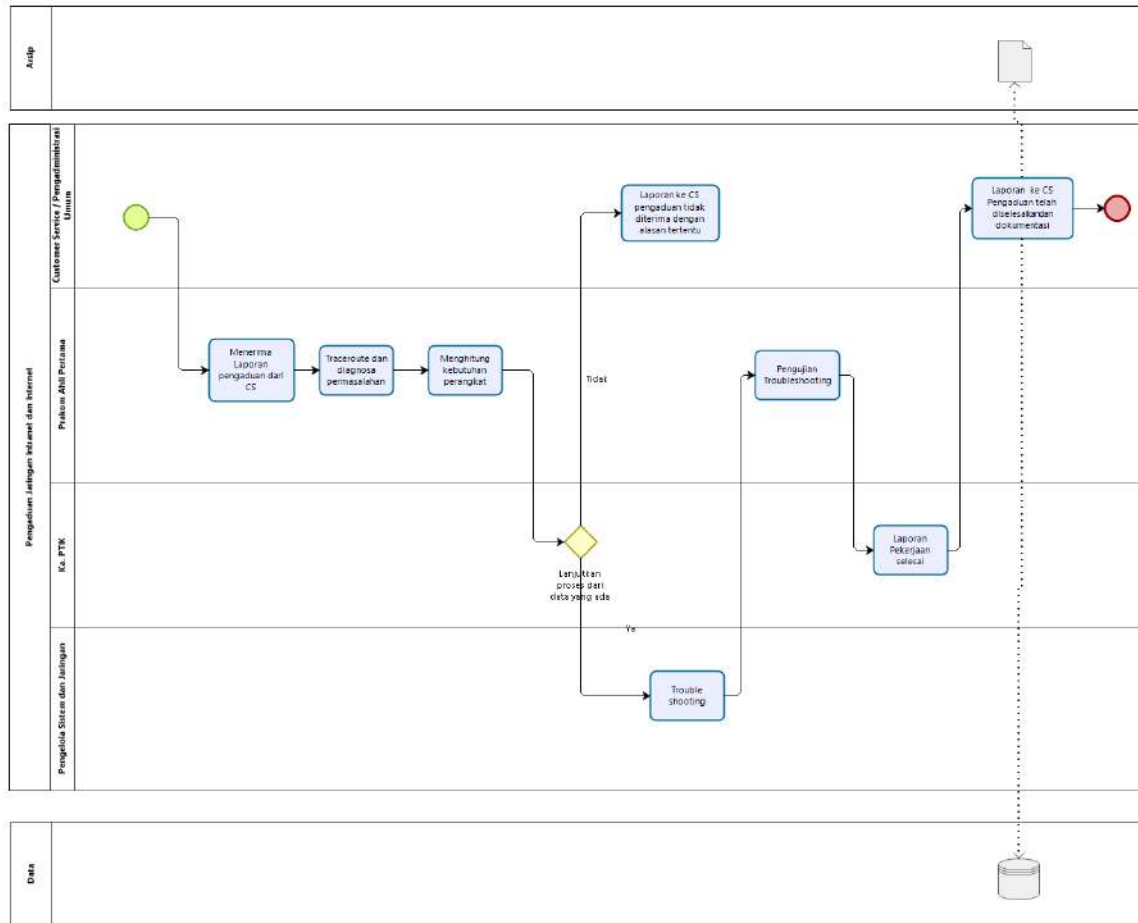



# 140 SOP Pengaduan Jaringan WIFI

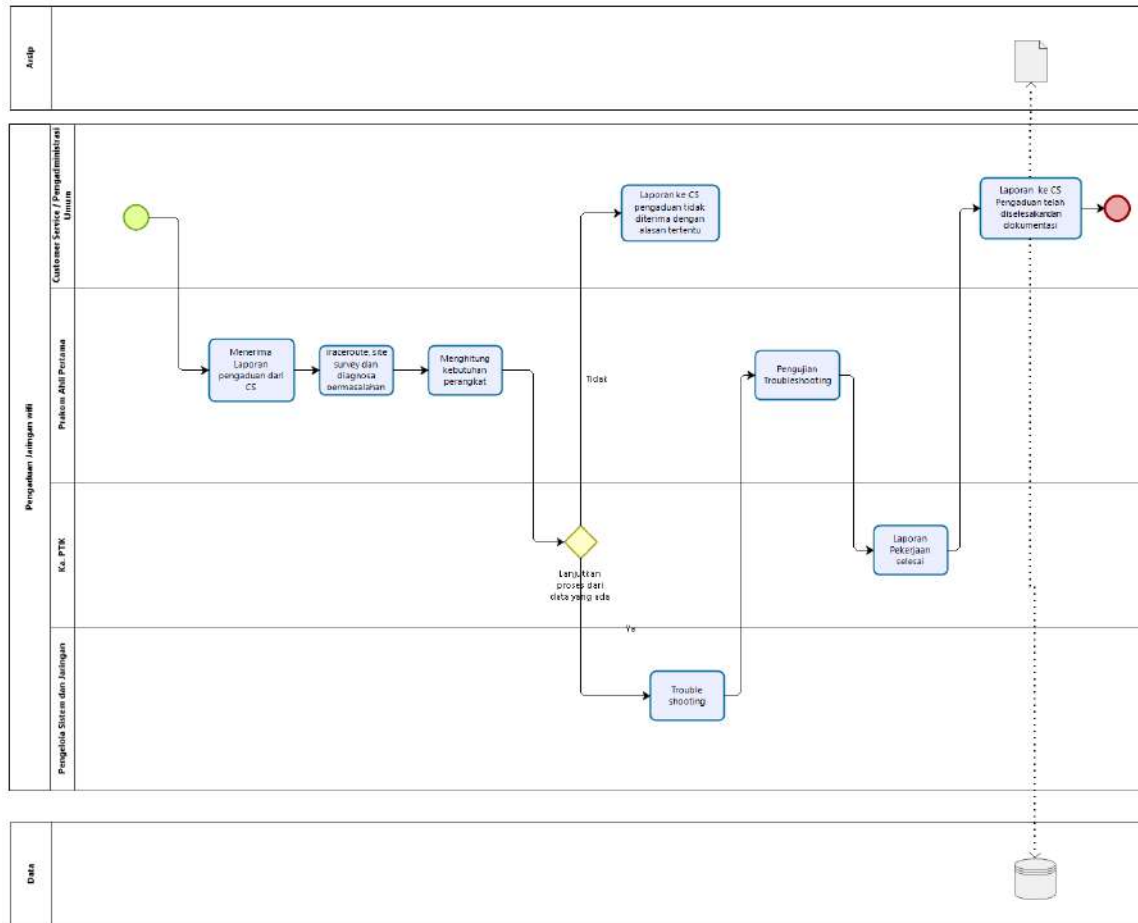



## 141 SOP Pengajuan Anggaran Pelaksanaan Kegiatan Kemahasiswaan

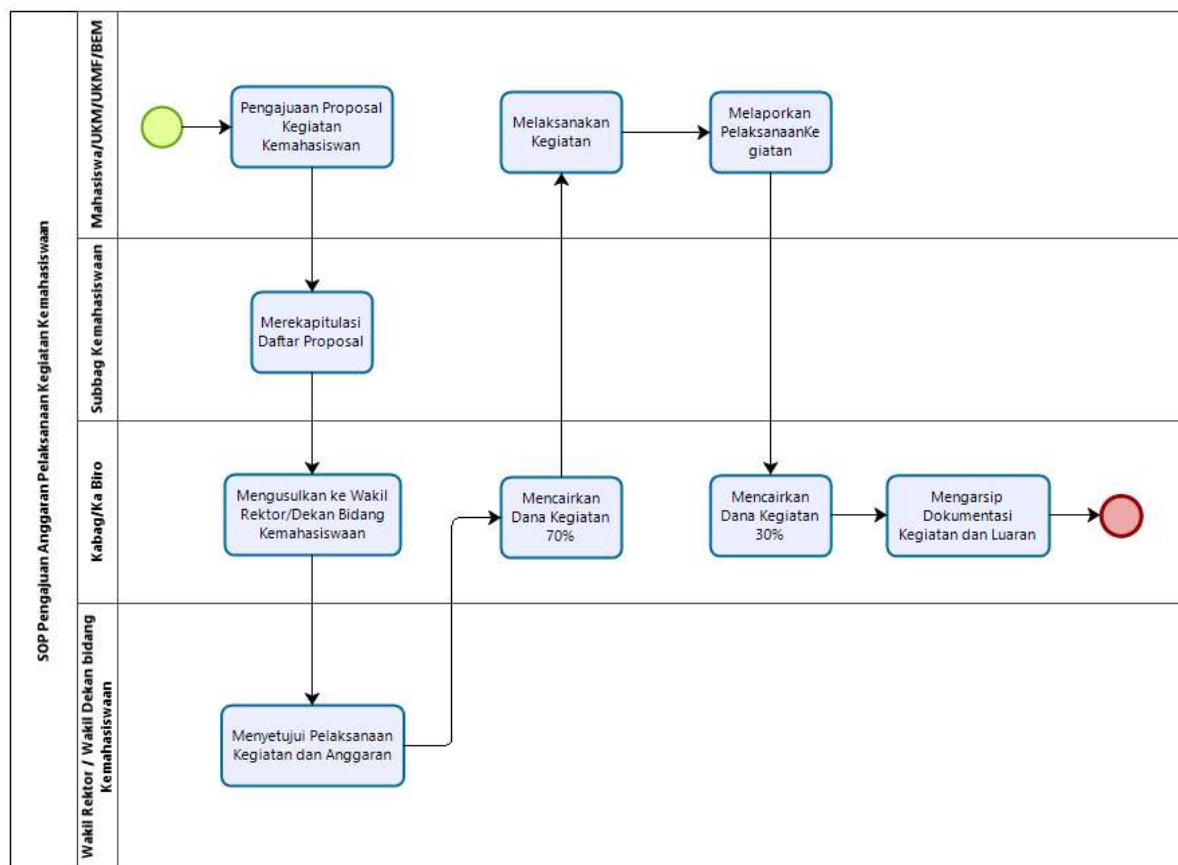





# 142 SOP Pengajuan SPP LS

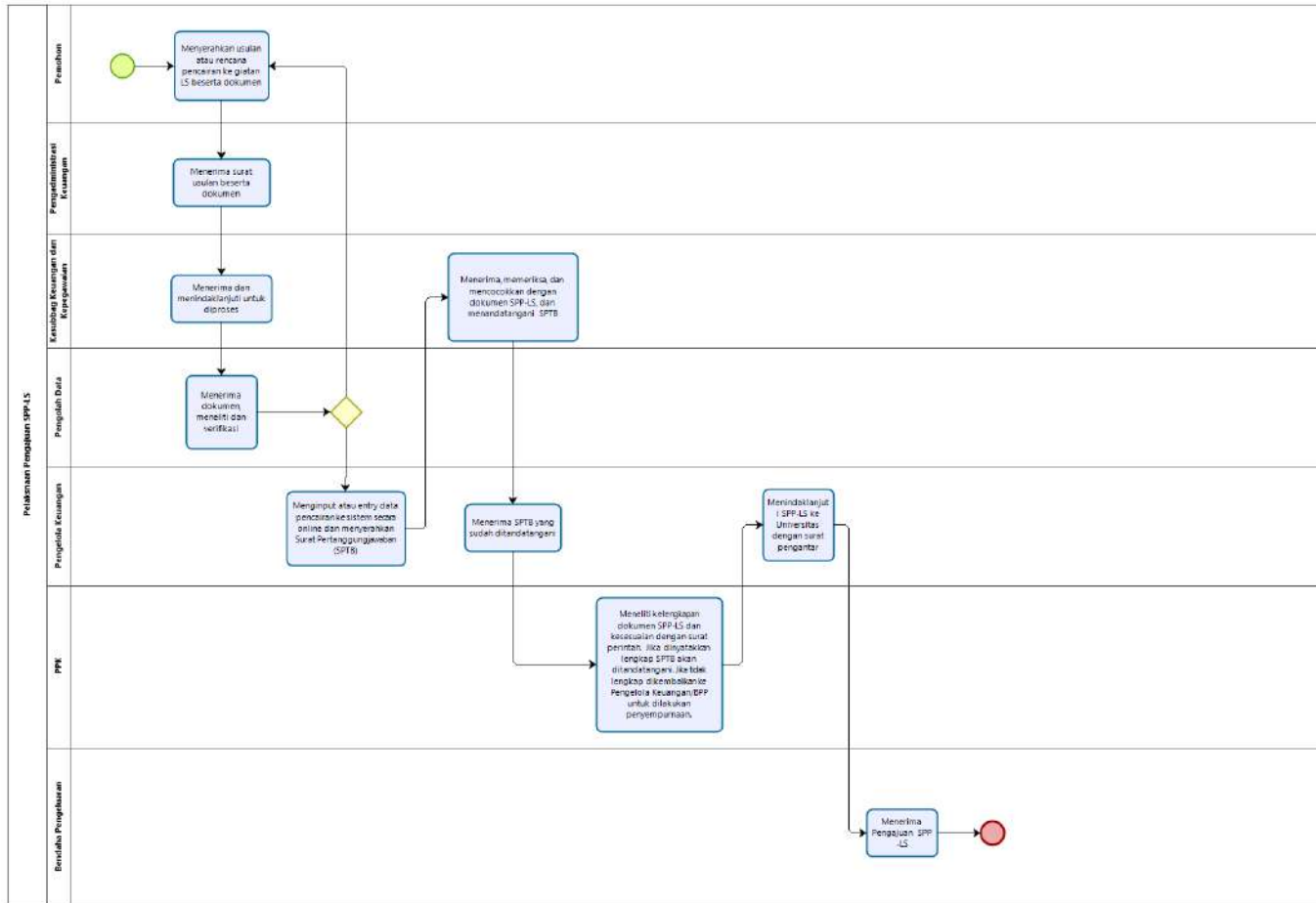



# 143 SOP Pengajuan Tugas Akhir

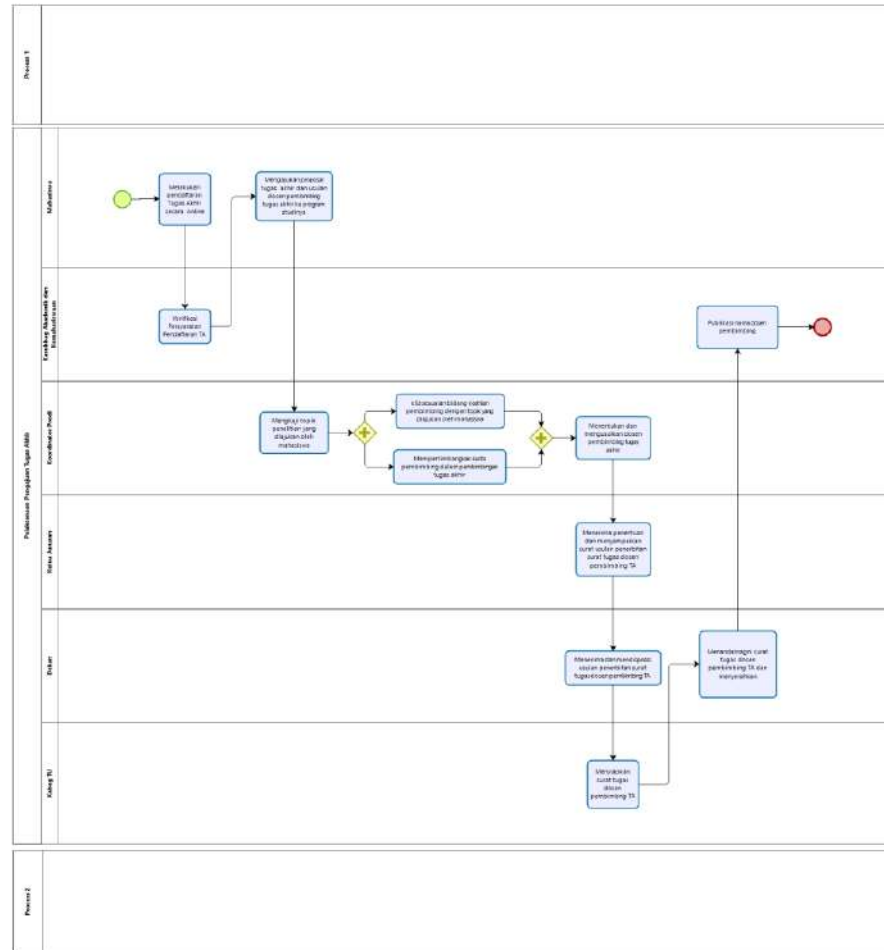



## 144 SOP Pengaktifan Kembali Dosen Studi Lanjut

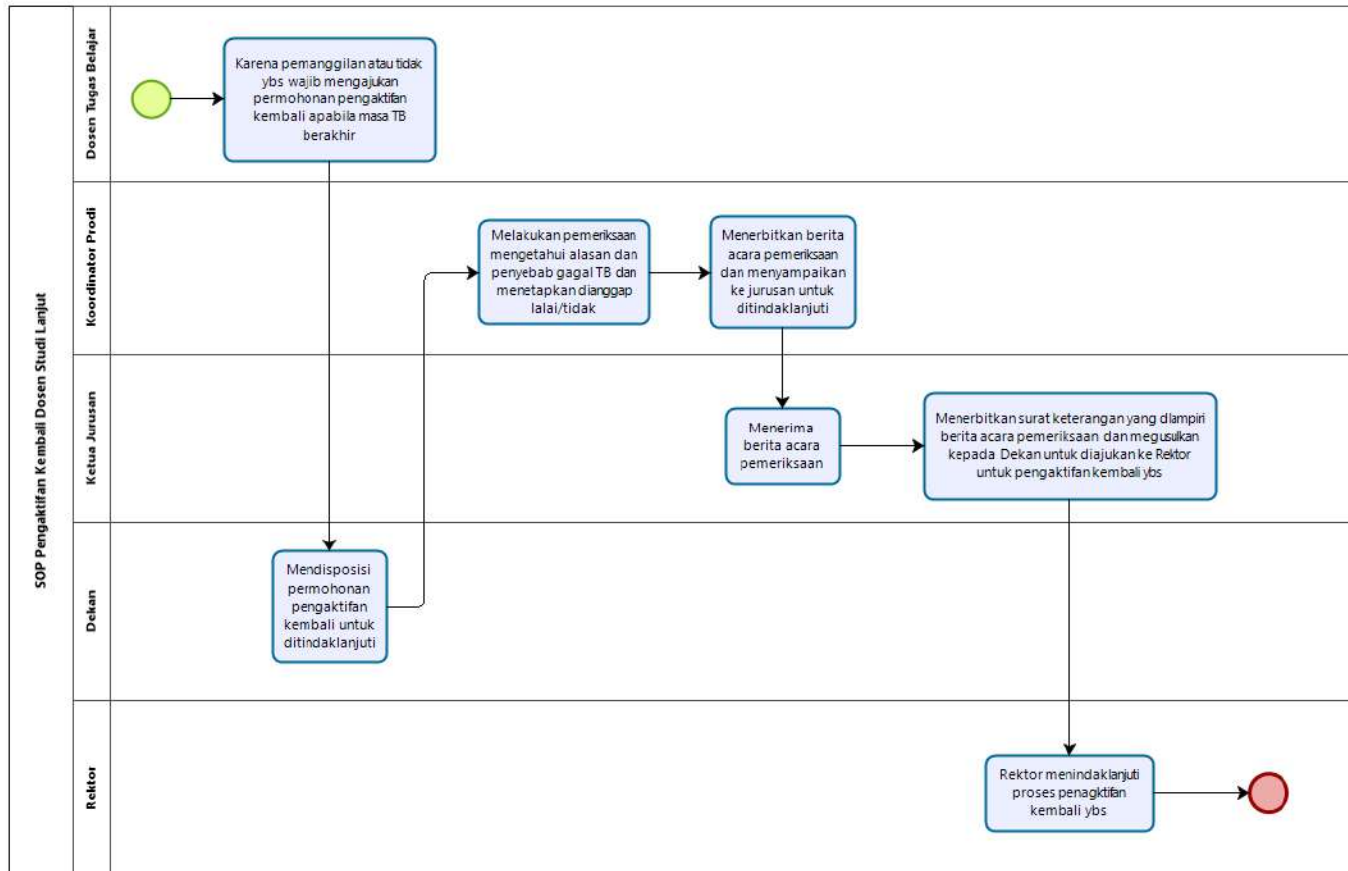



# 145 SOP Pengangkatan PNS

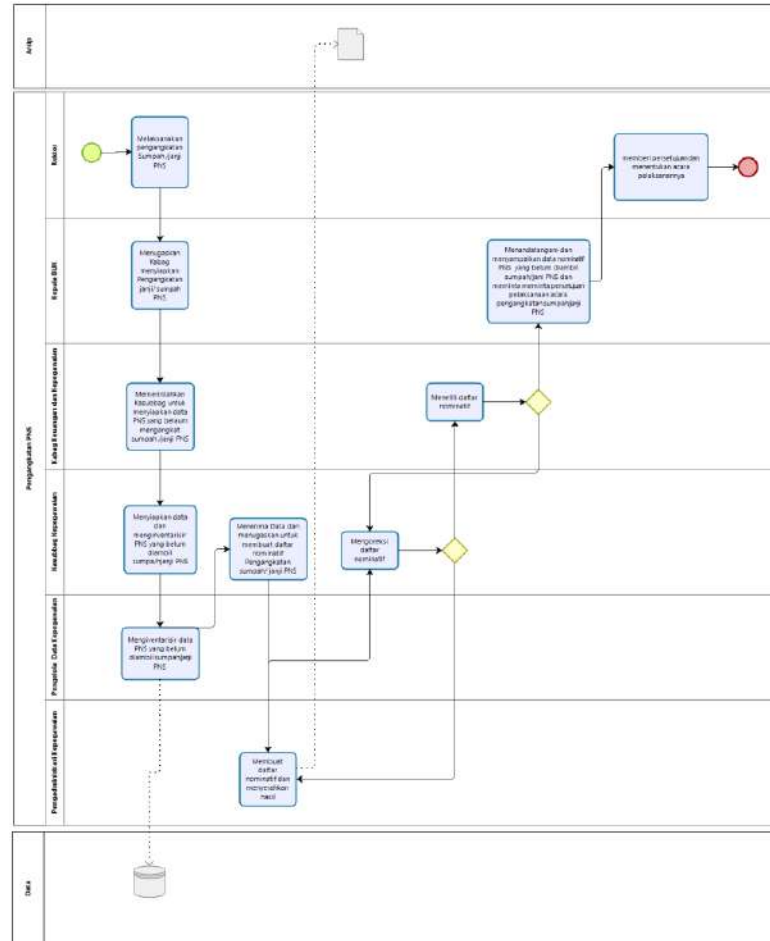



## 146 SOP Pengembangan Pengadaan Infrastruktur Perangkat device IT

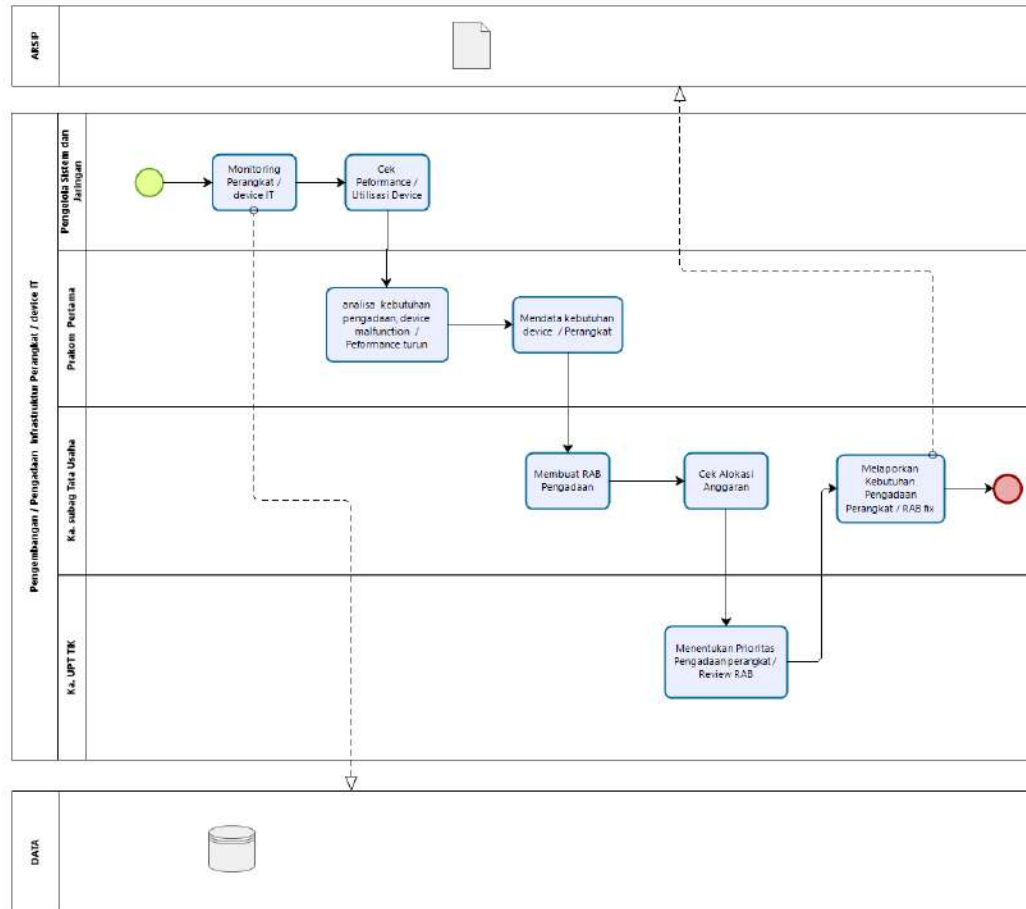



# 147 SOP Pengembangan Infrastruktur Backbone Fiber Optic

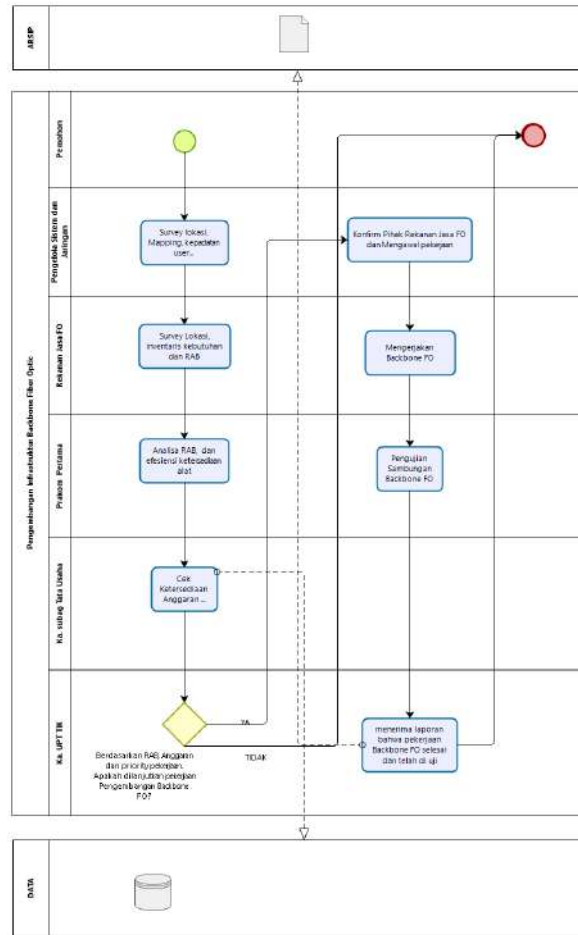



# 148 SOP Pengembangan Infrastruktur Backbone Fiber Optic PtP wifi

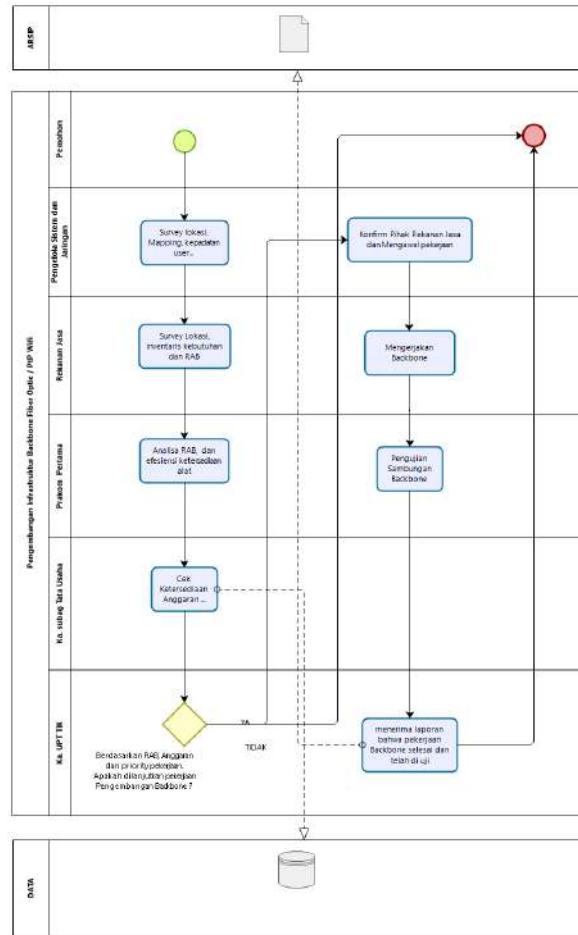



# 149 SOP Pengembangan Infrastruktur Wifi Area

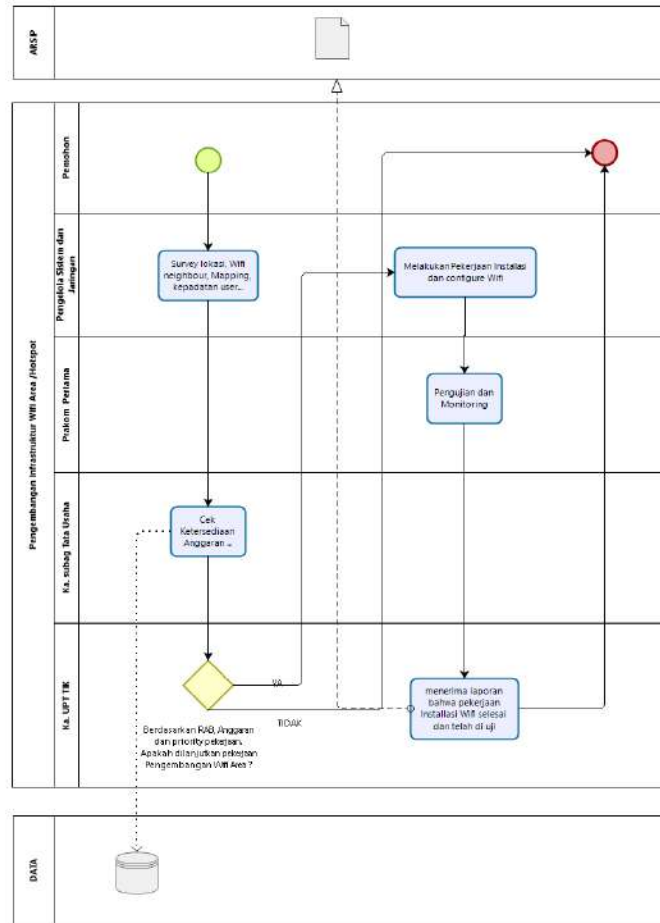





## 150 SOP Pengembangan Metode Pembelajaran

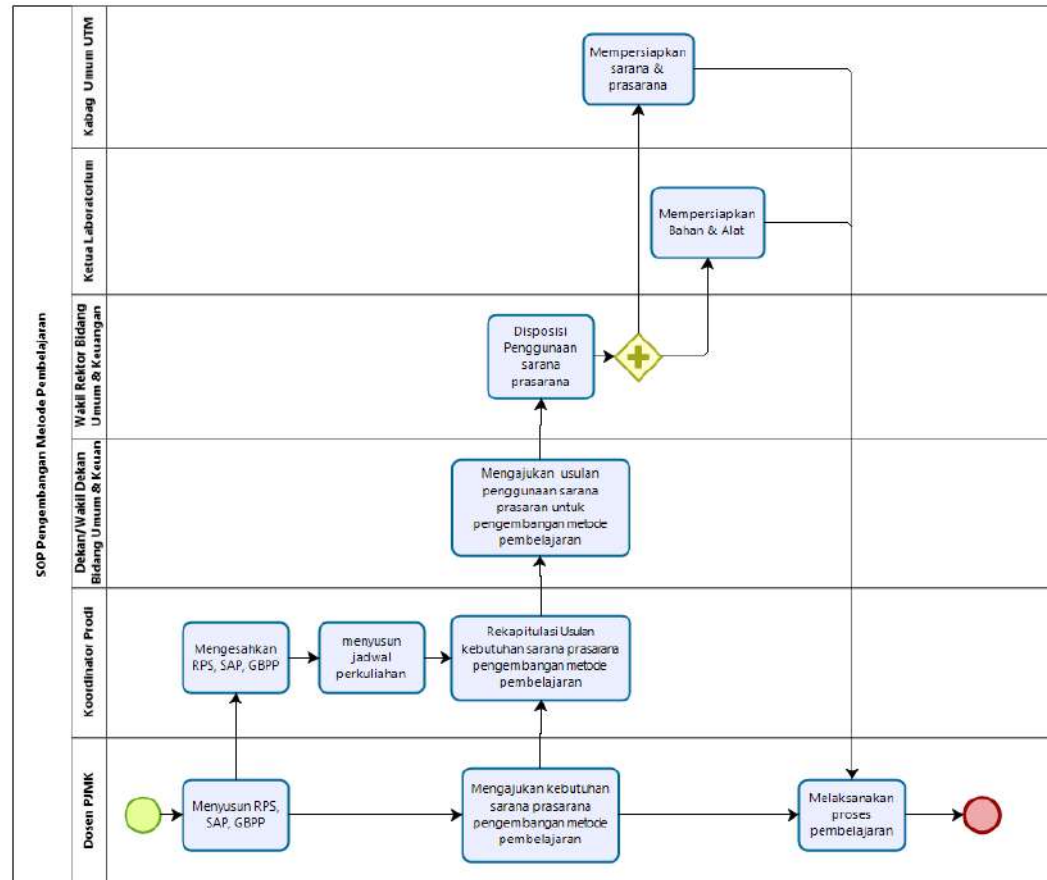



# 151 SOP Pengganti Ijazah

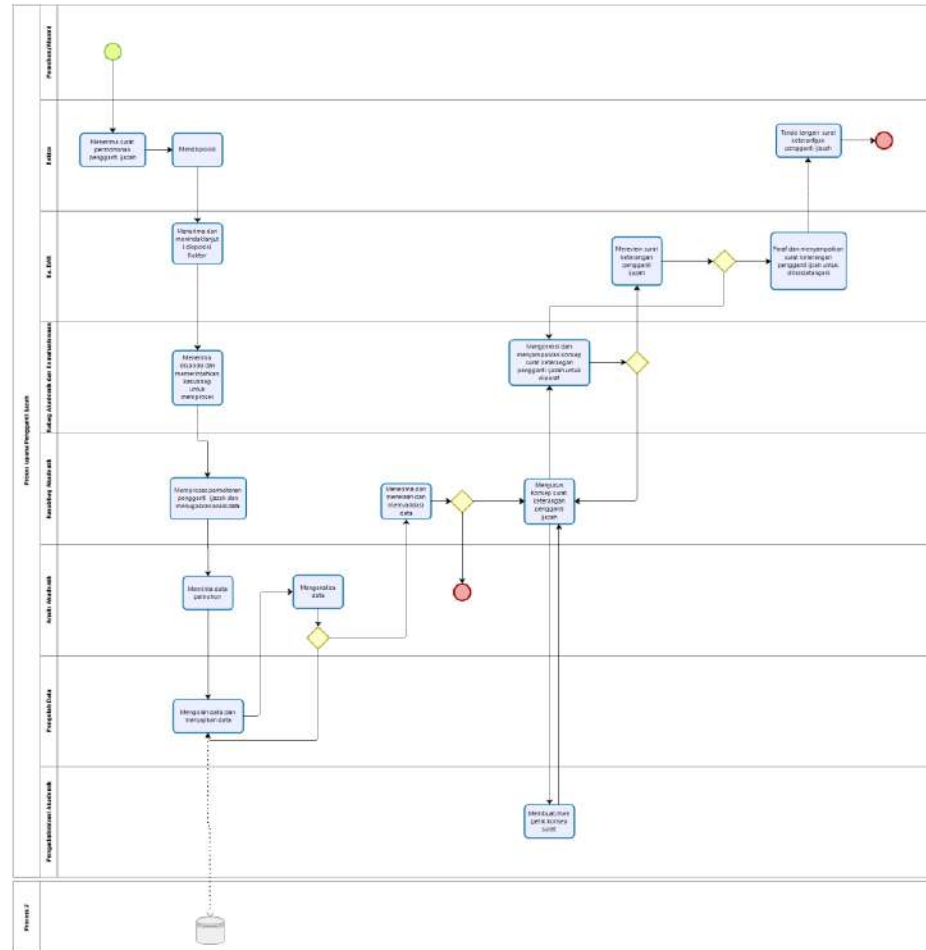



## 152 SOP Pengisian KPRS

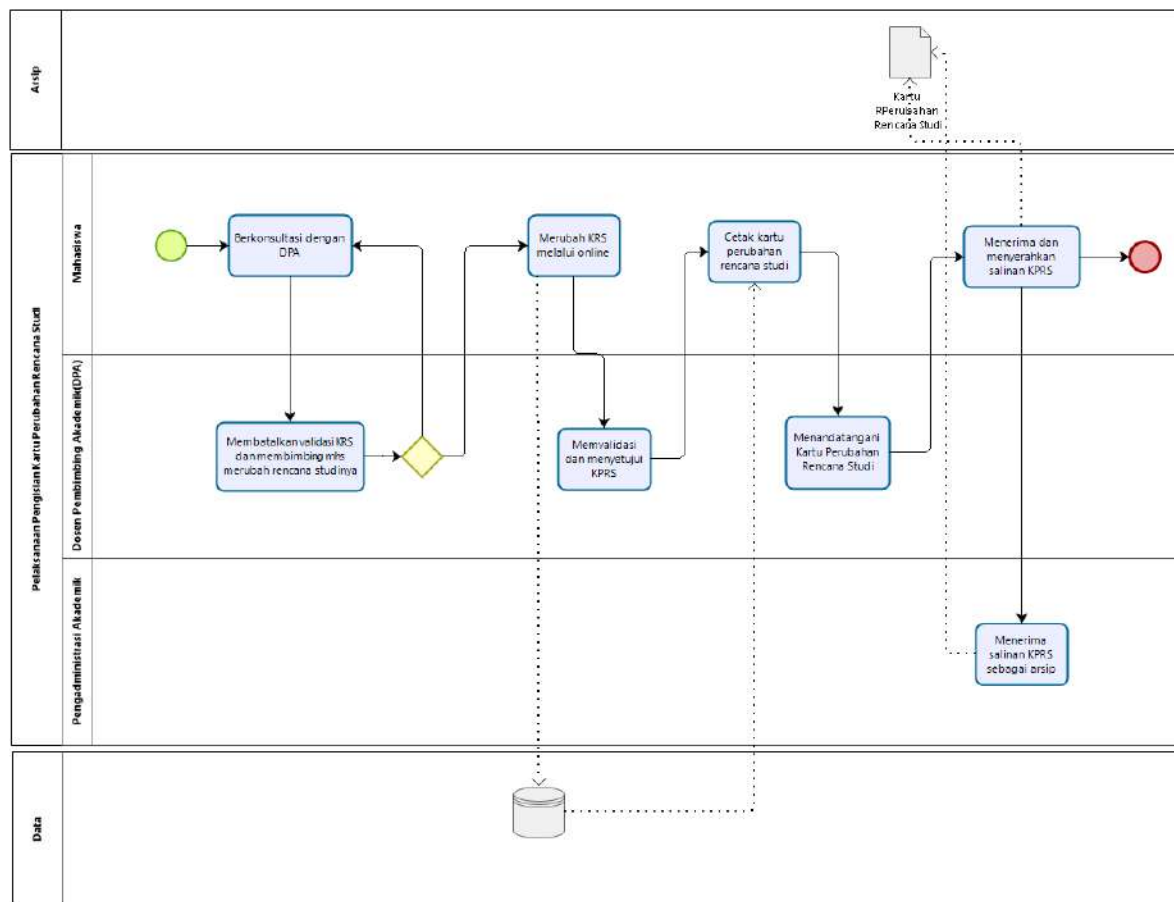



# 153 SOP Pengisian KRS

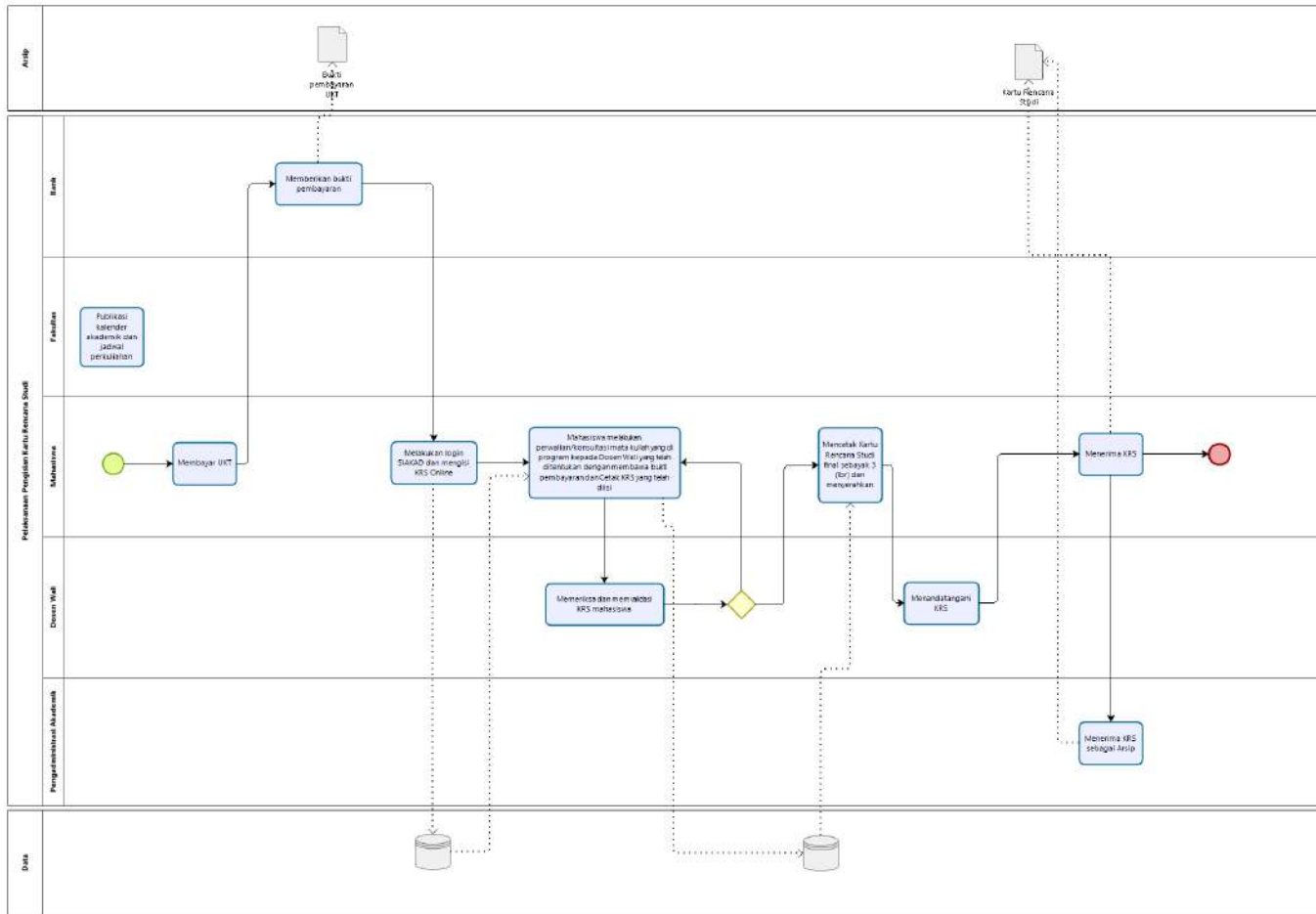



## 154 SOP Pengolahan Bahan Pustaka

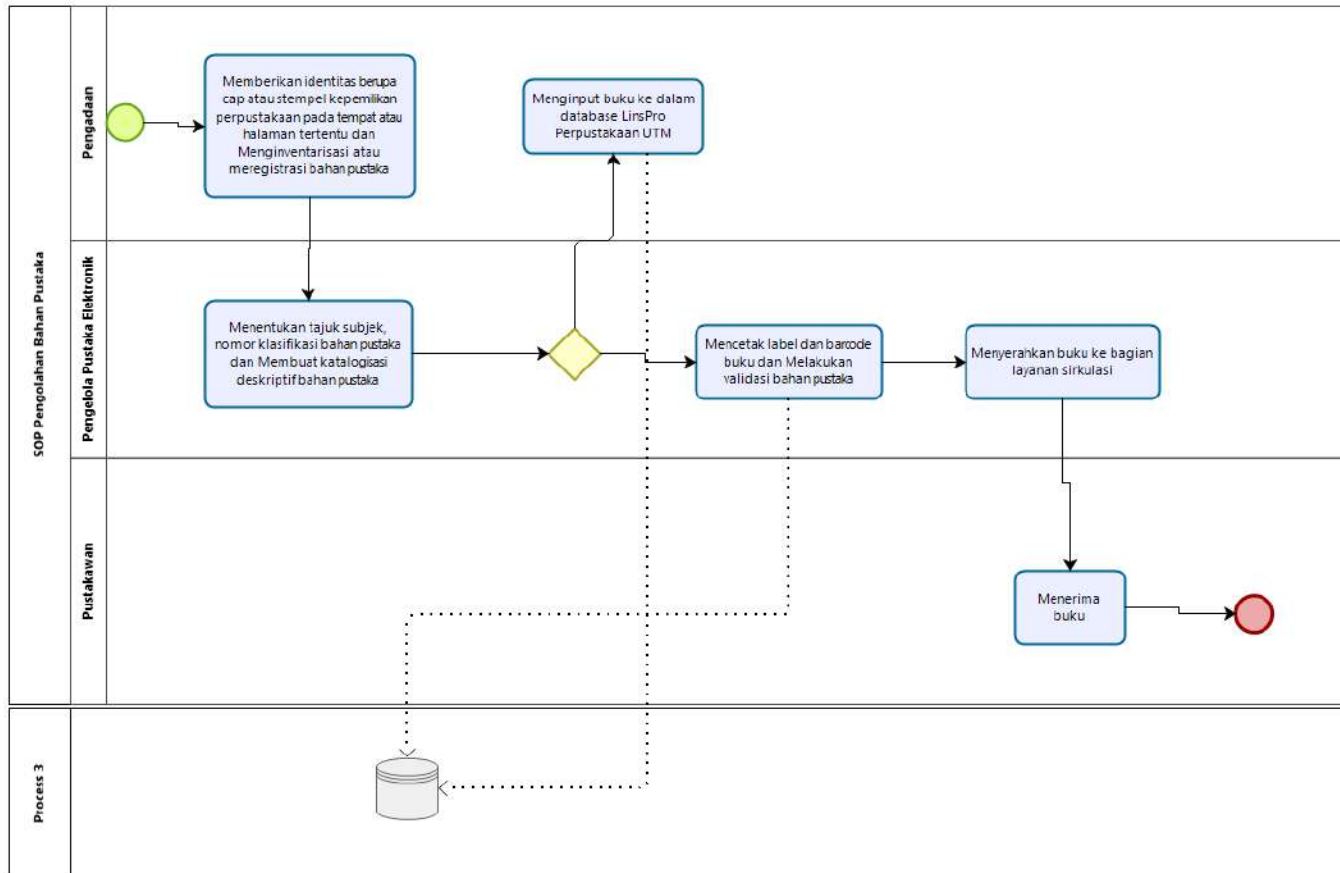



# 155 SOP Pengukuhan Guru Besar

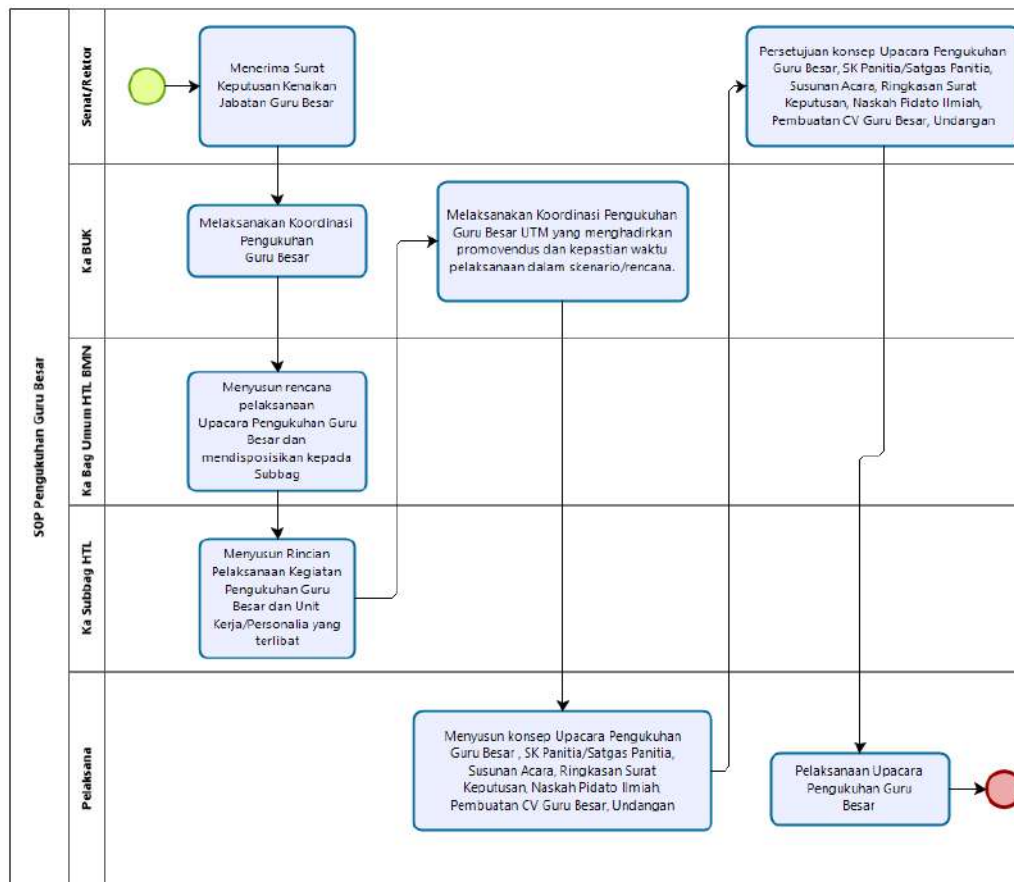



## 156 SOP Pengumpulan Laporan Akhir Penelitian Abdimas

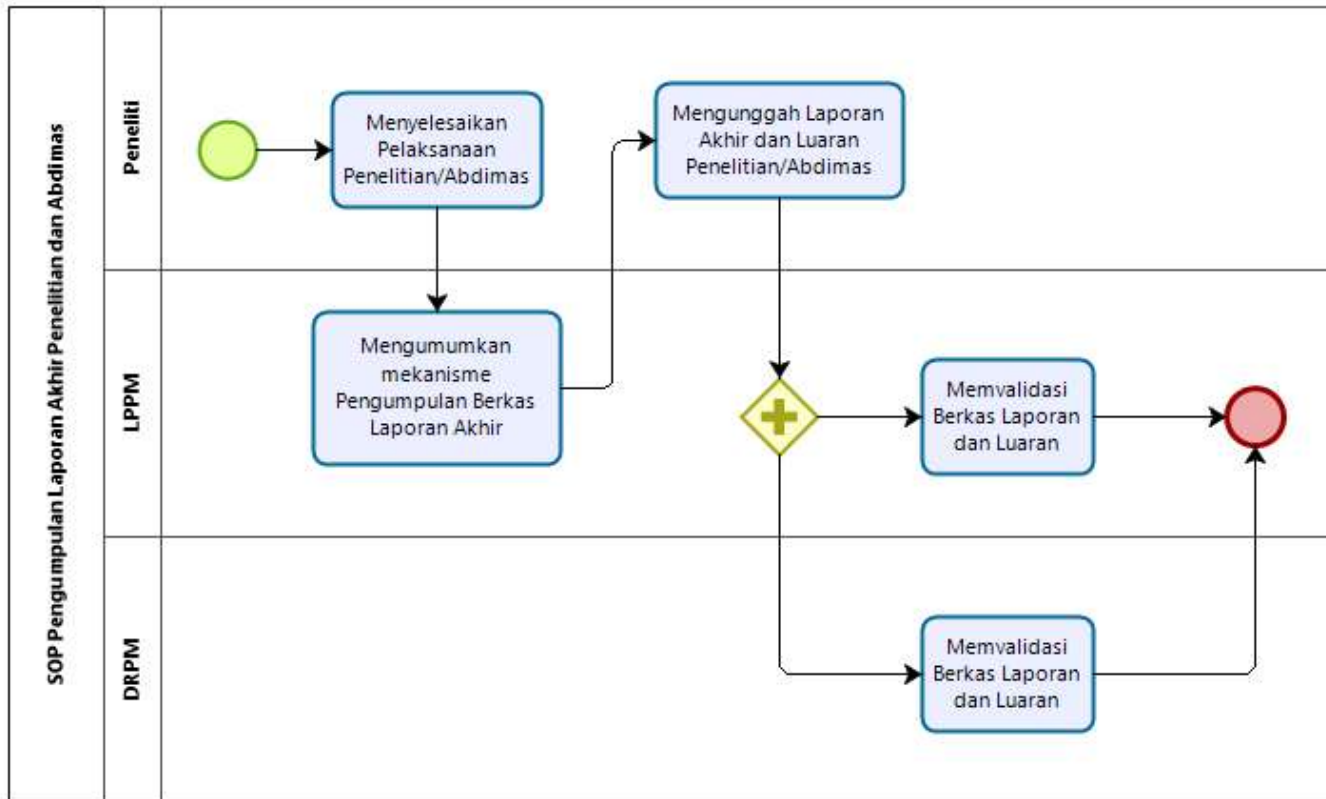



# 157 SOP Pengumpulan Perundang-undangan

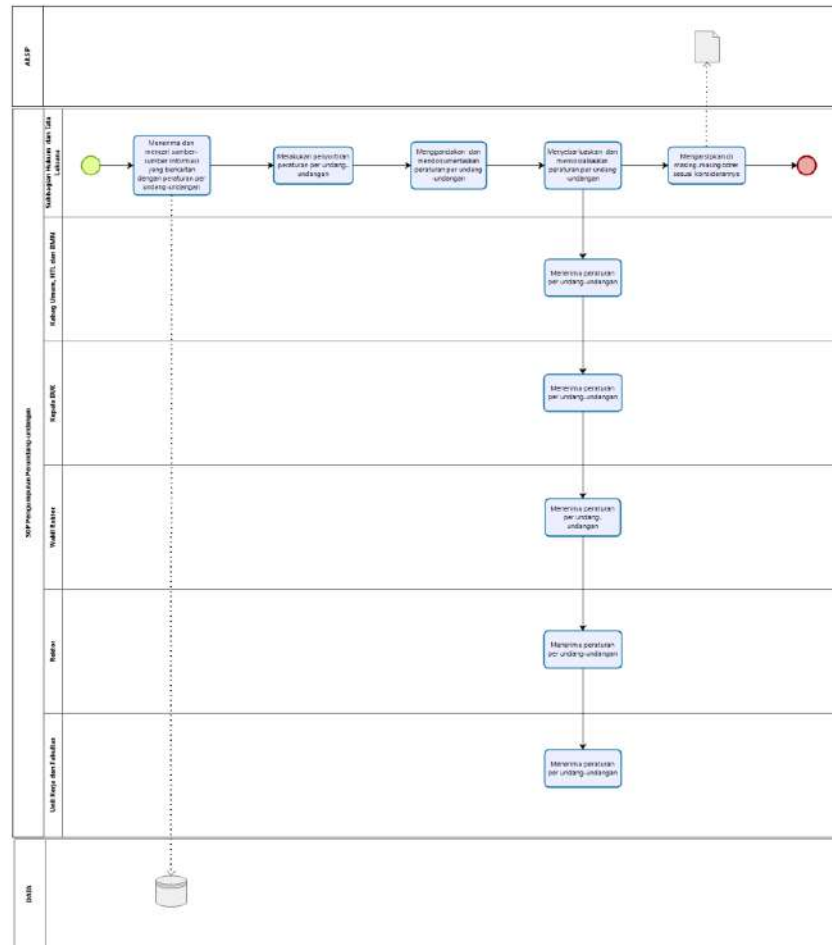





## 158 SOP Pengumuman Tawaran Abdimas

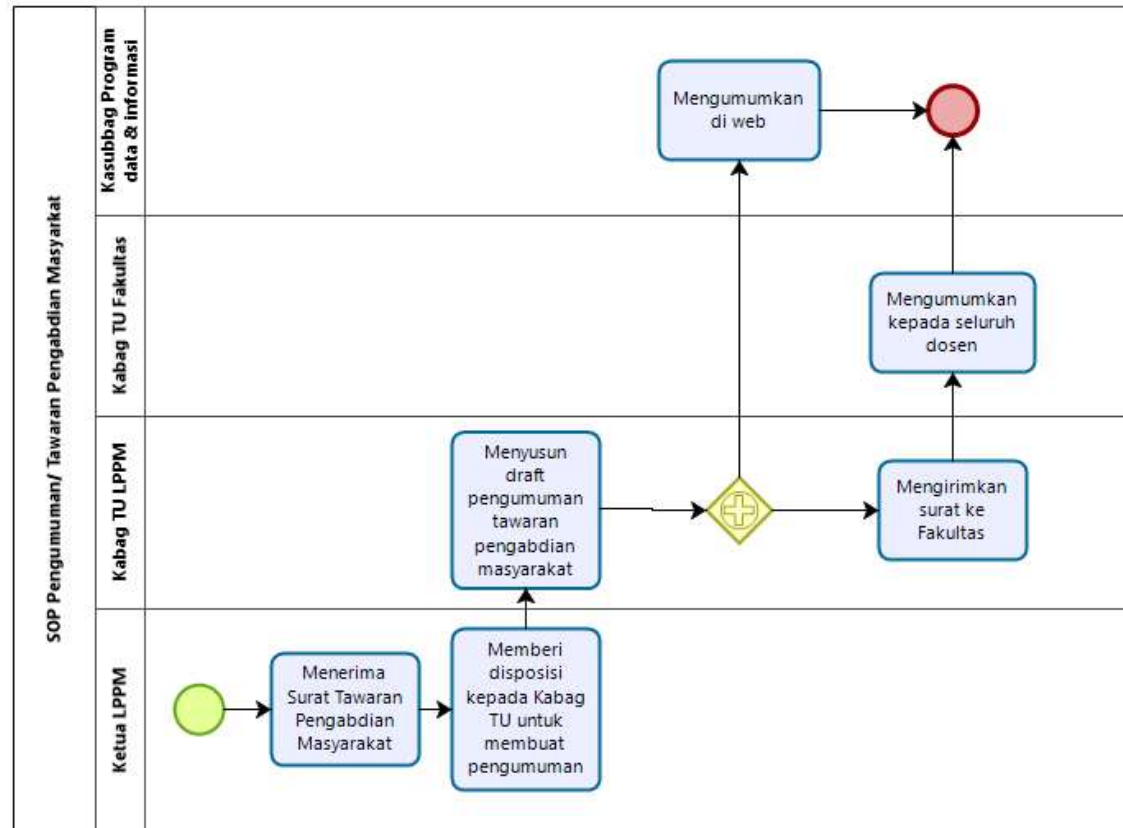



## 159 SOP Pengumuman Tawaran Penelitian

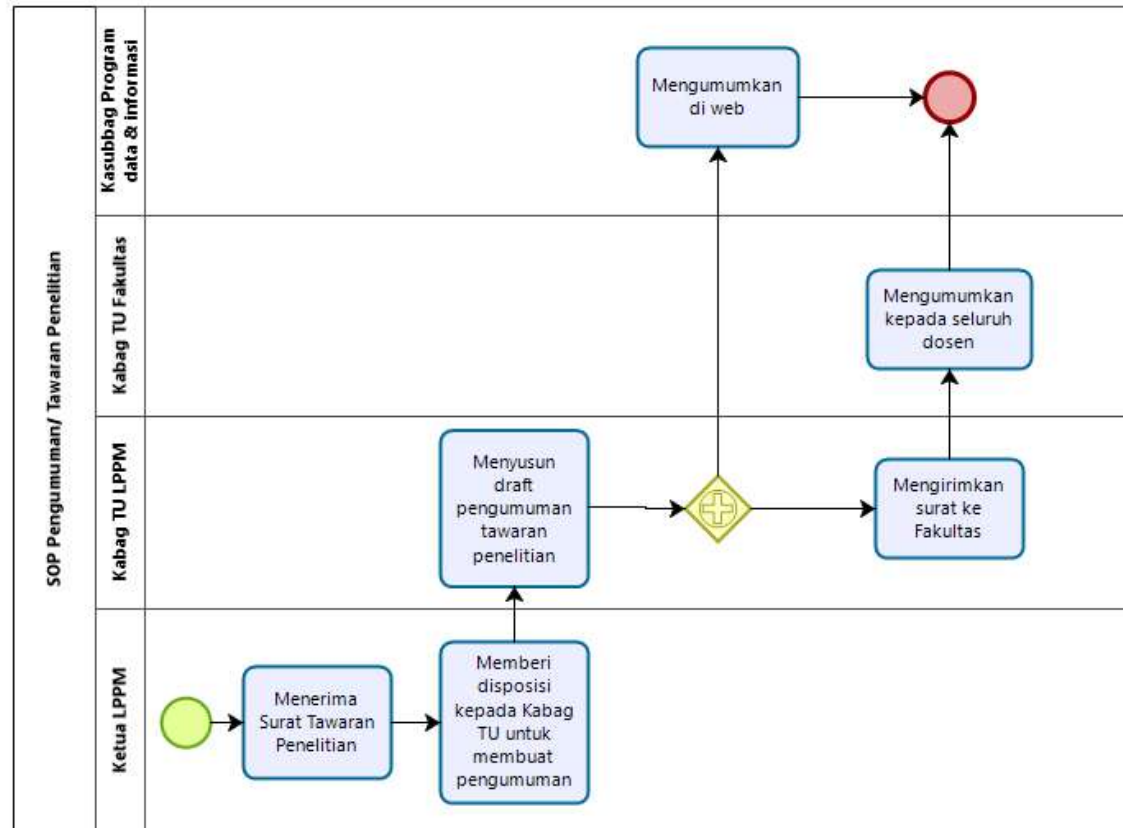



## 160 SOP Pengusulan Proposal Abdimas

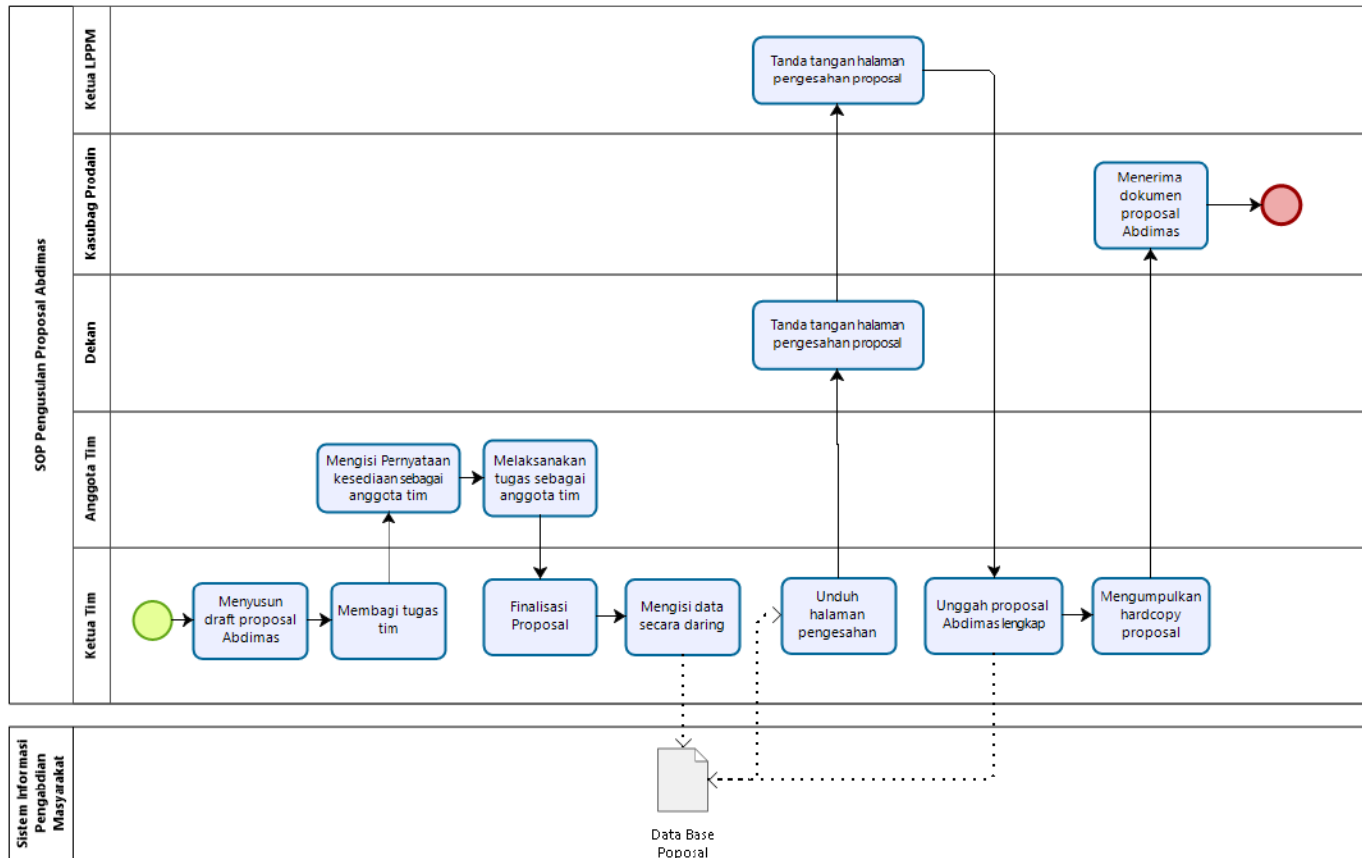



# 161 SOP Pengusulan Proposal Penelitian

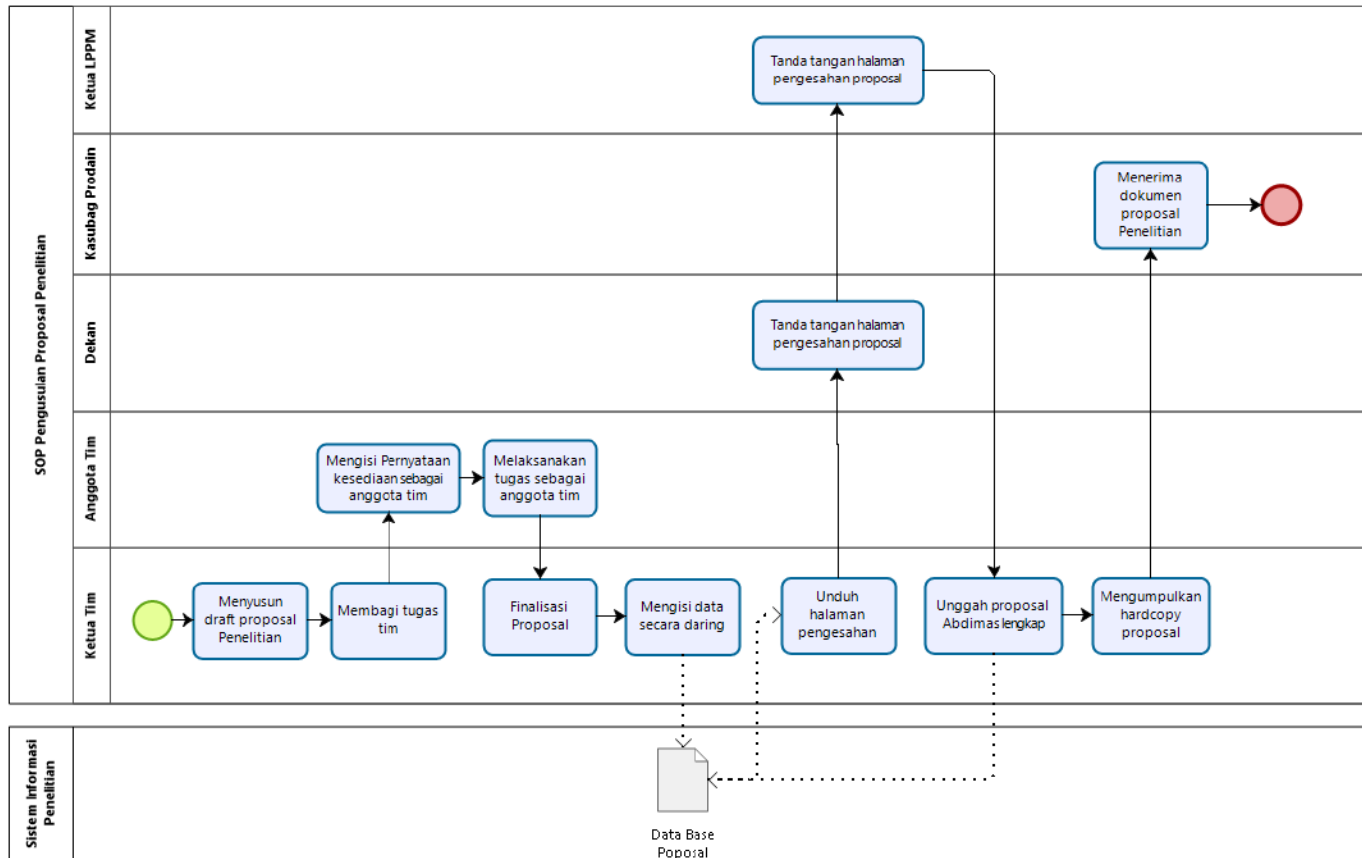



## 162 SOP Penyediaan UP dan TUP

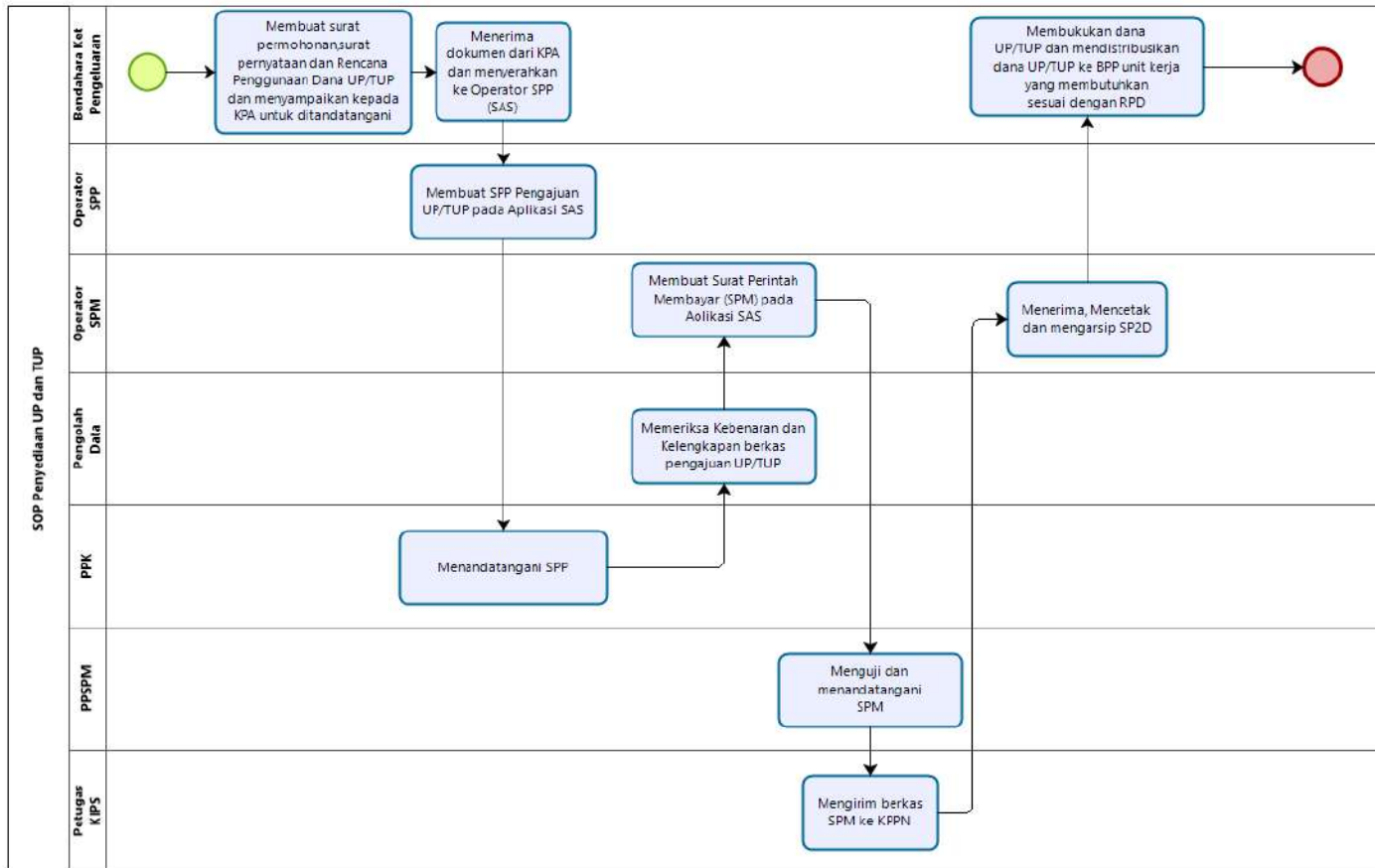



## 163 SOP Penyerahan Sripsi Tugas Akhir

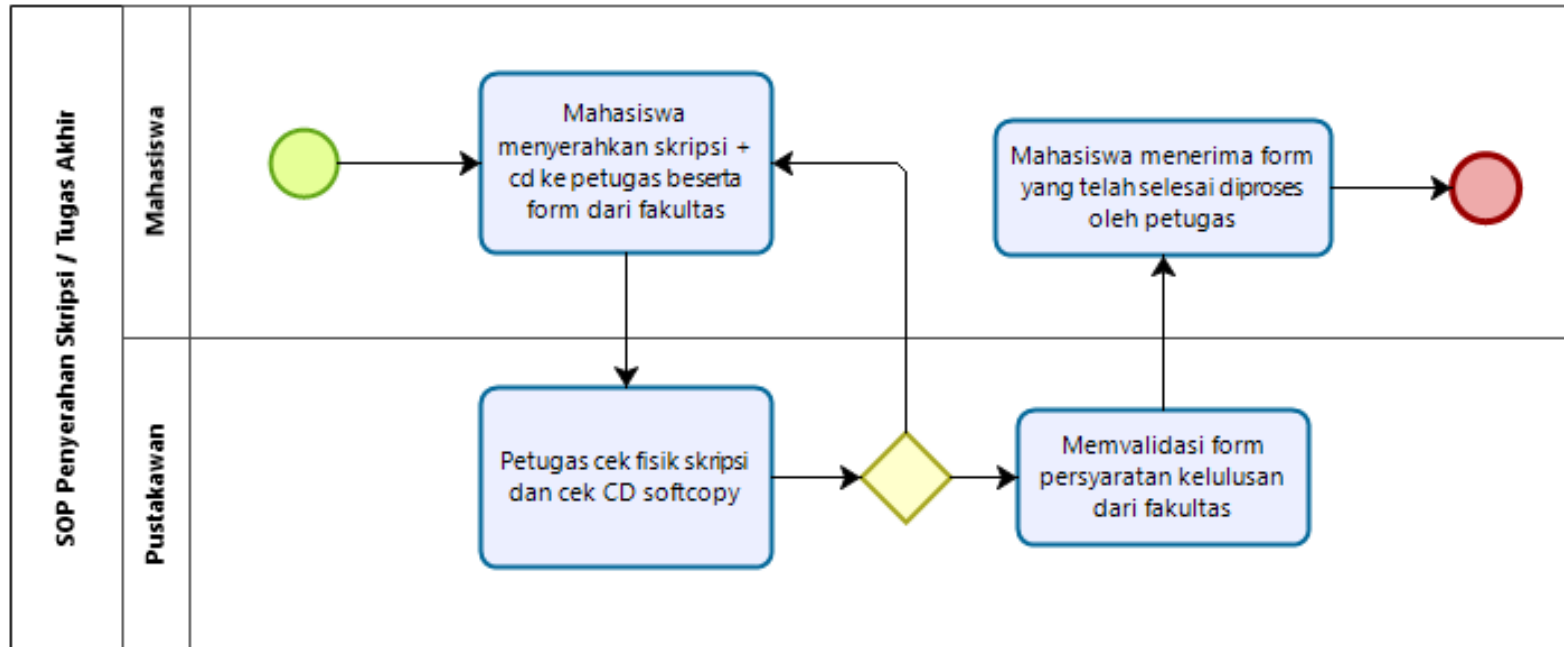



# 164 SOP Penyusunan Kurikulum

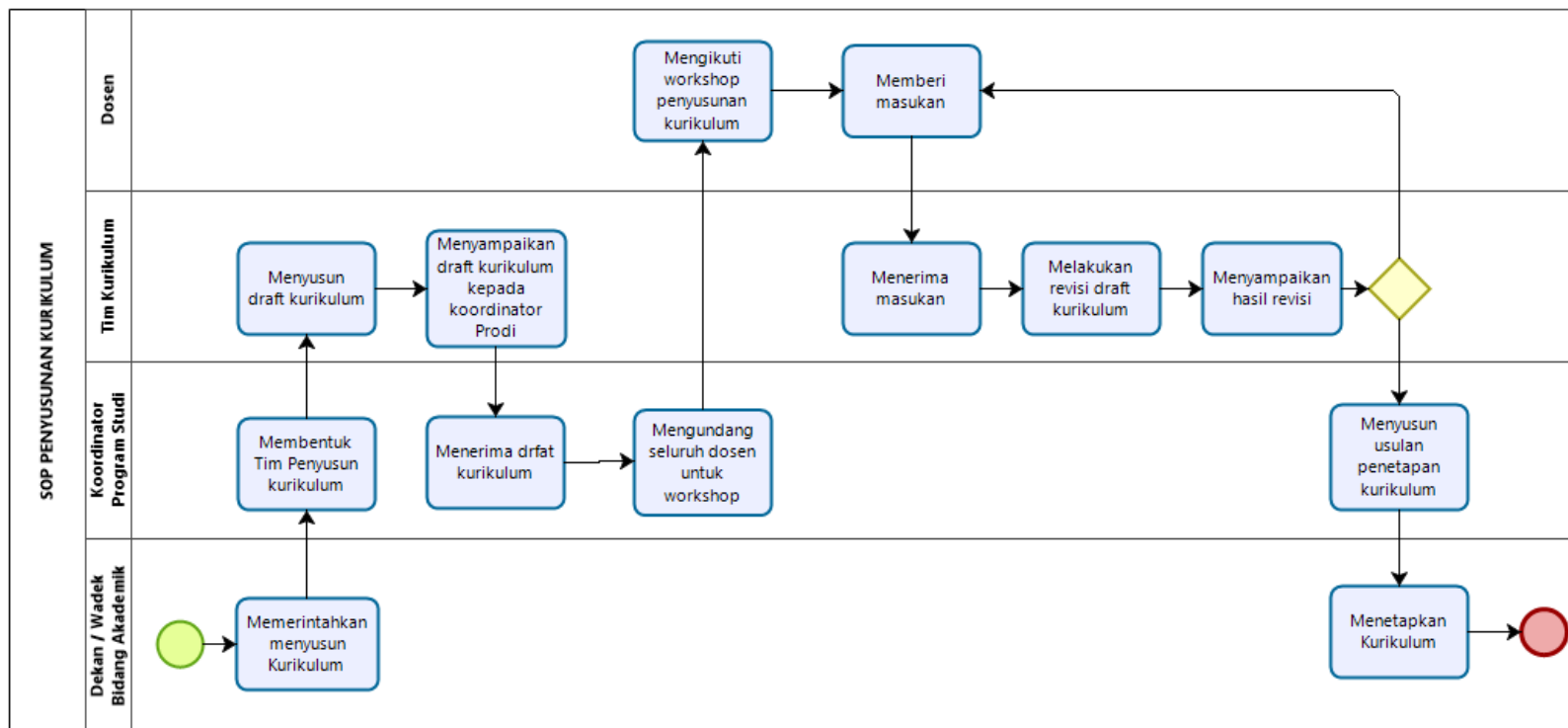



## 165 SOP Penyusunan Kurikulum di Fakultas

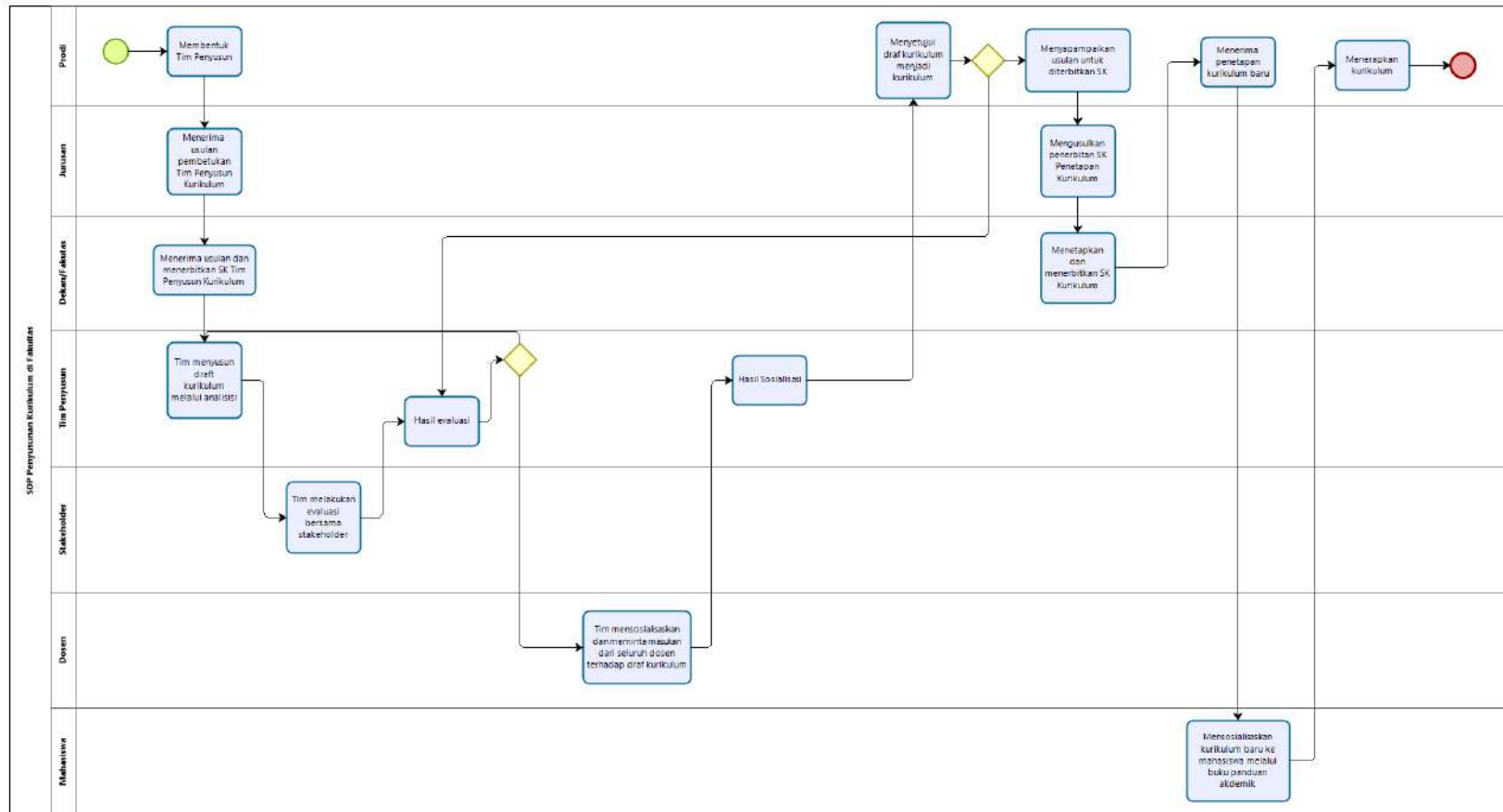





## 166 SOP Penyusunan Laporan Hasil Evaluasi

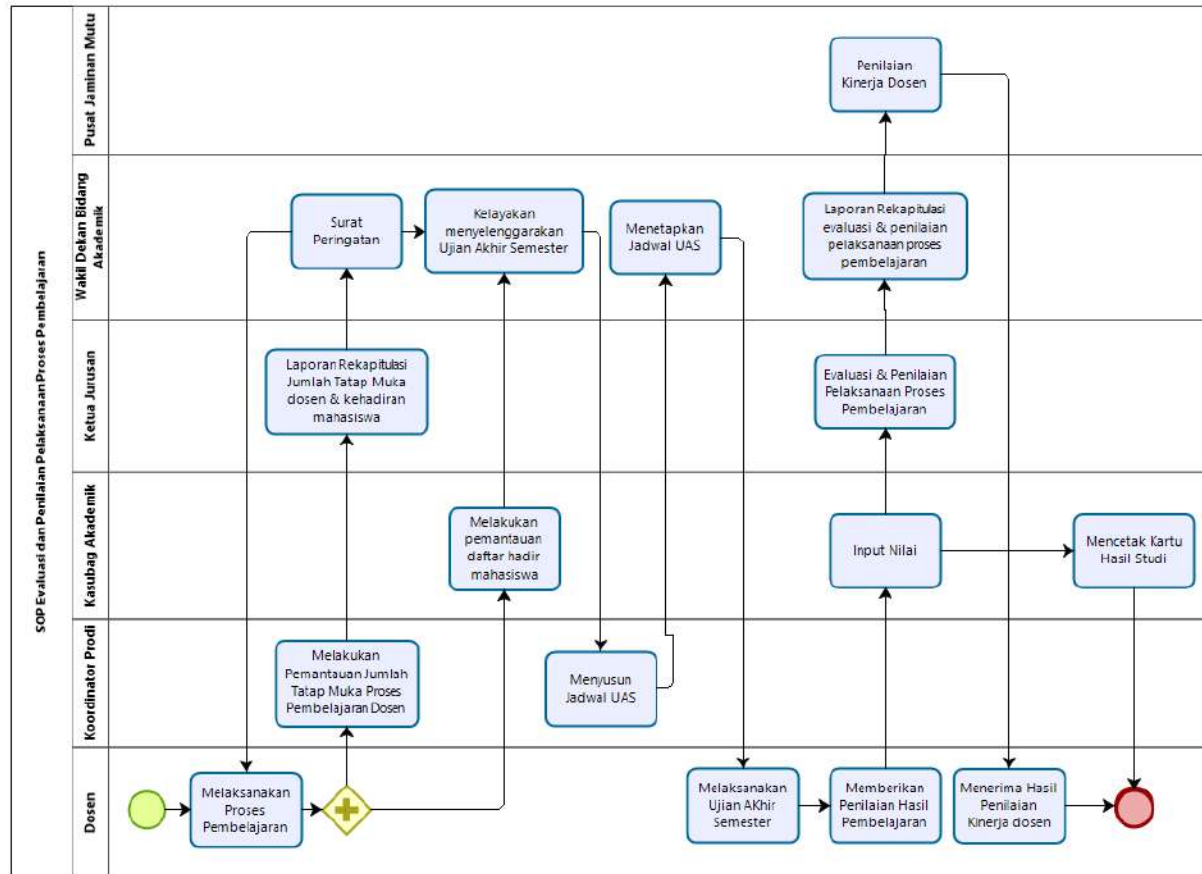



## 167 SOP Penyusunan Laporan Kinerja (LAKIN)

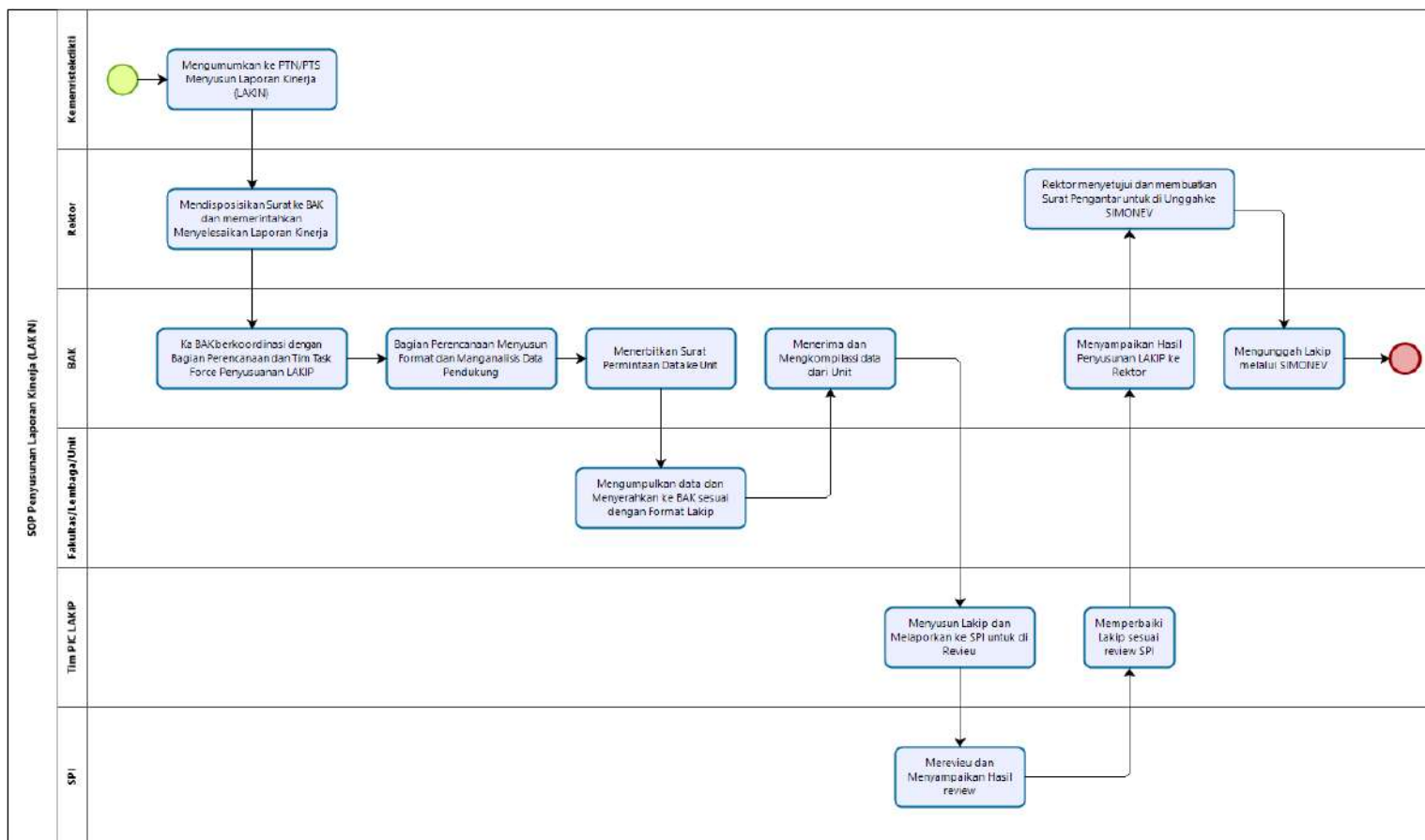



# 168 SOP Penyusunan Penetapan Kinerja

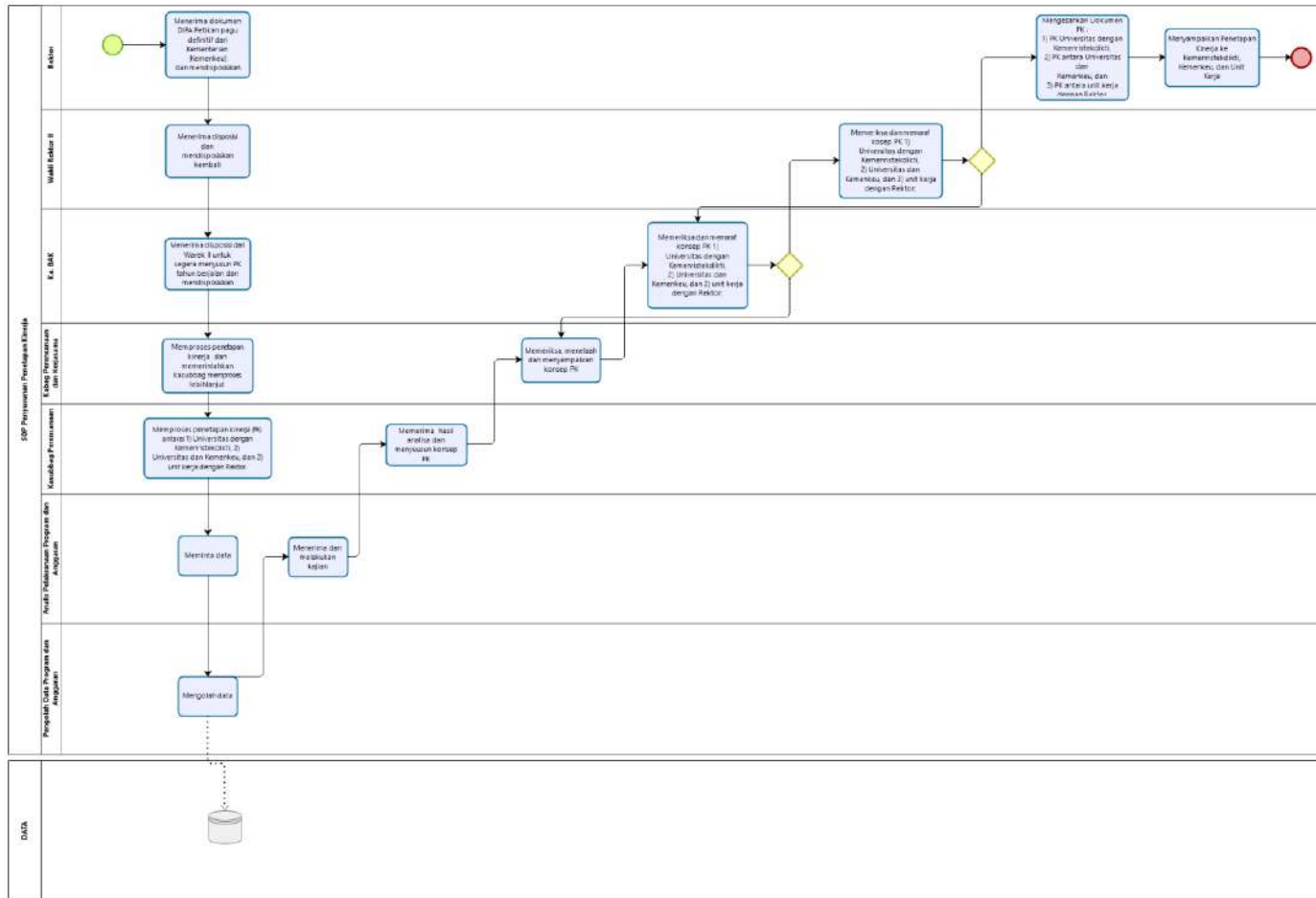



## 169 SOP Penyusunan Peraturan Perundang-Undangan

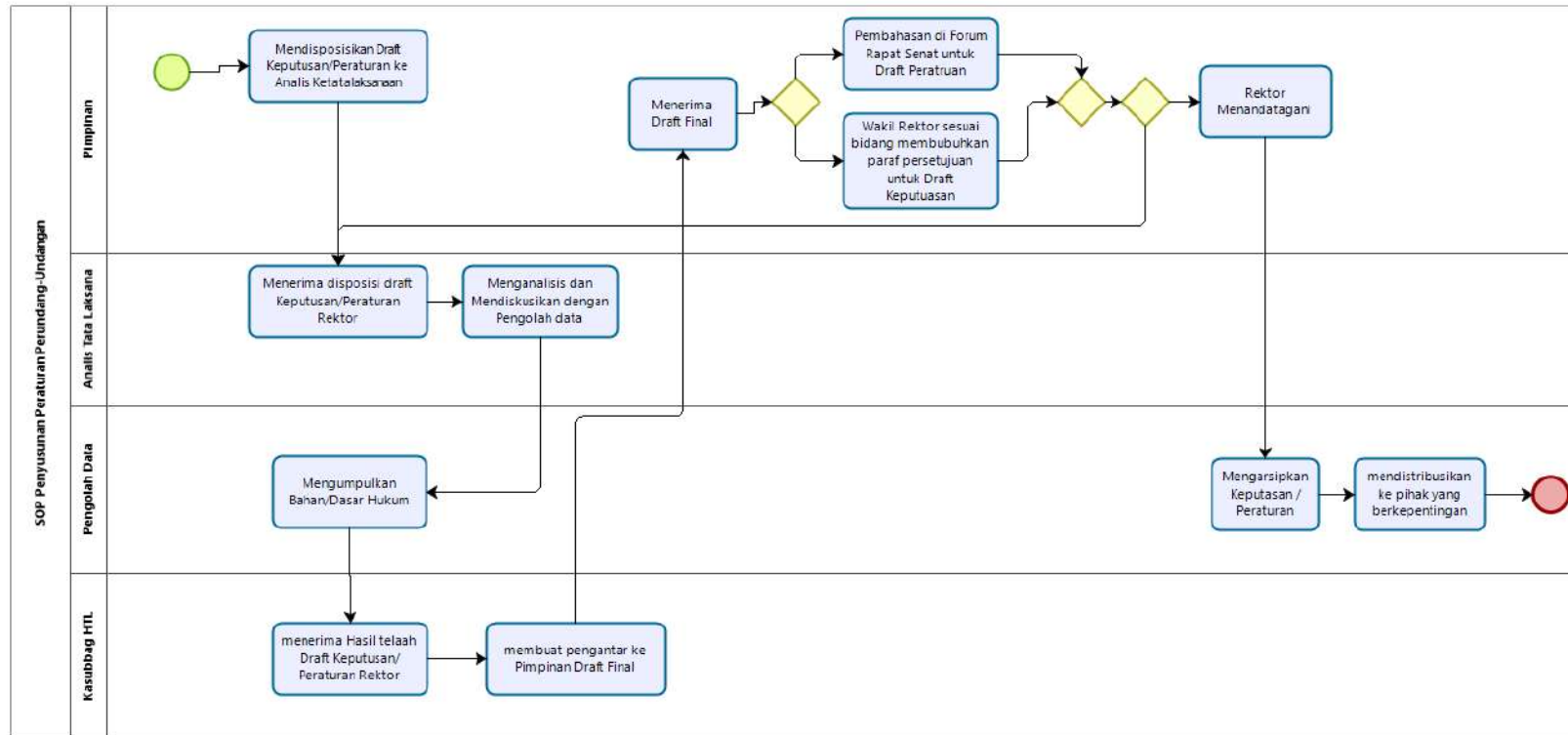



## 170 SOP Penyusunan Peraturan Rektor

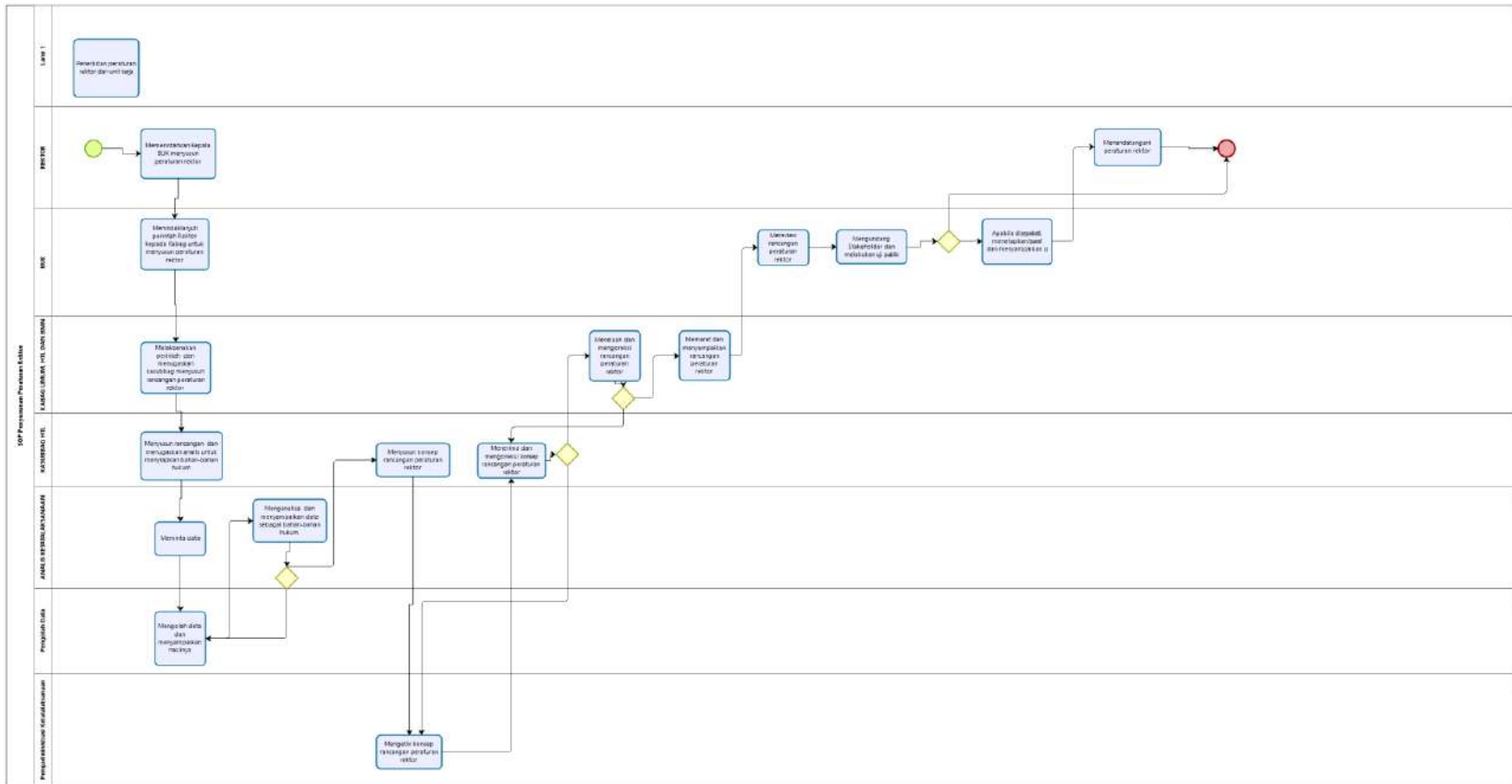



# 171 SOP Penyusunan rencana, tujuan, objek, dan ruang lingkup audit

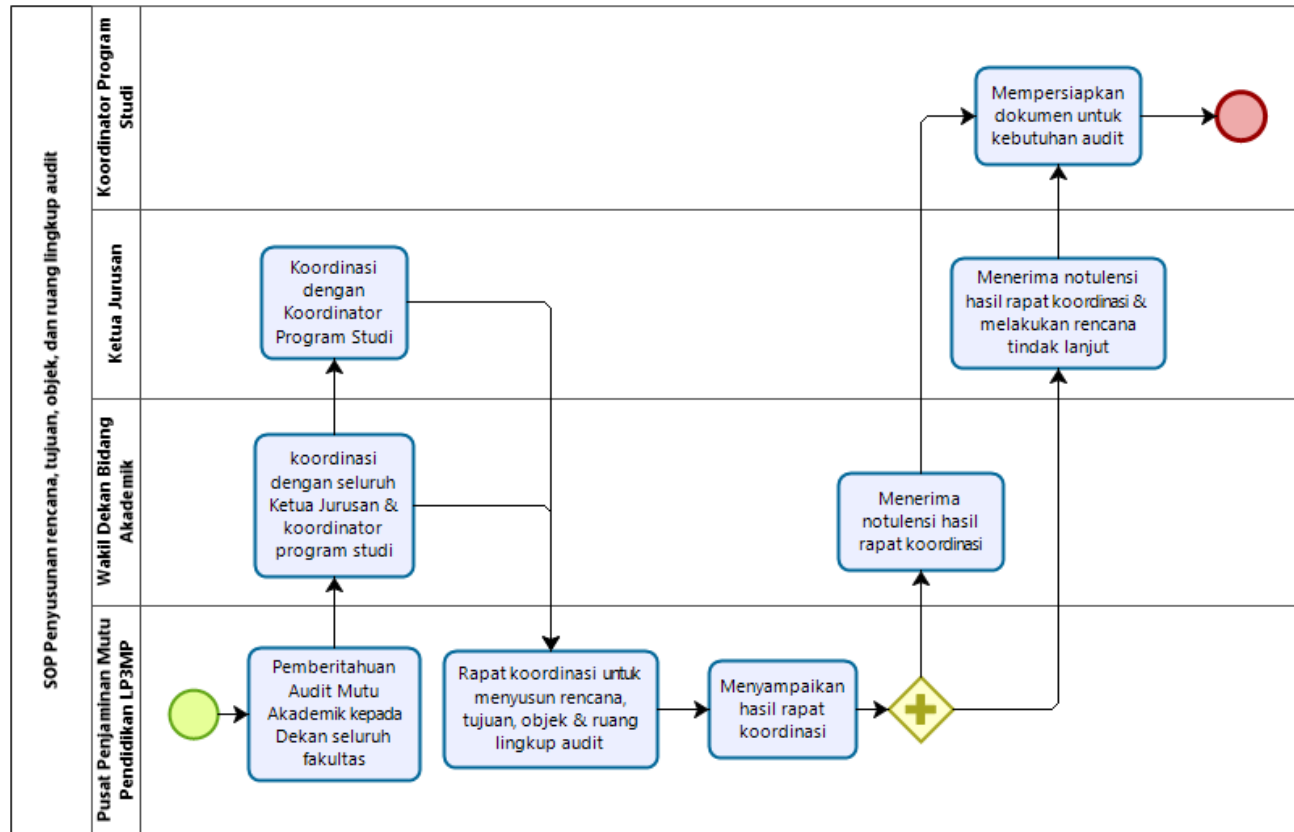



# 172 SOP Penyusunan SK Rektor

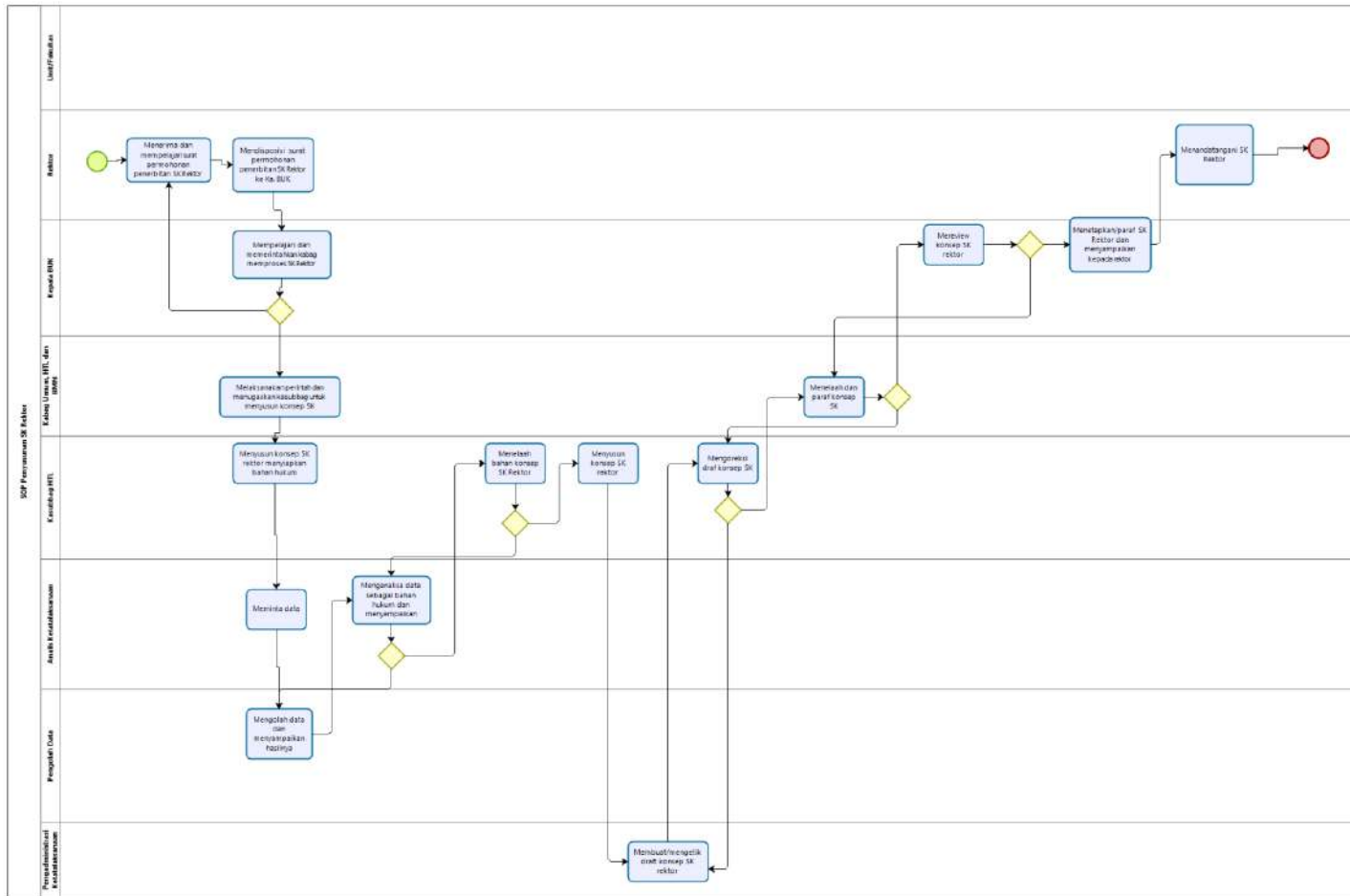







# 174 SOP Perbaikan Sarana Prasarana

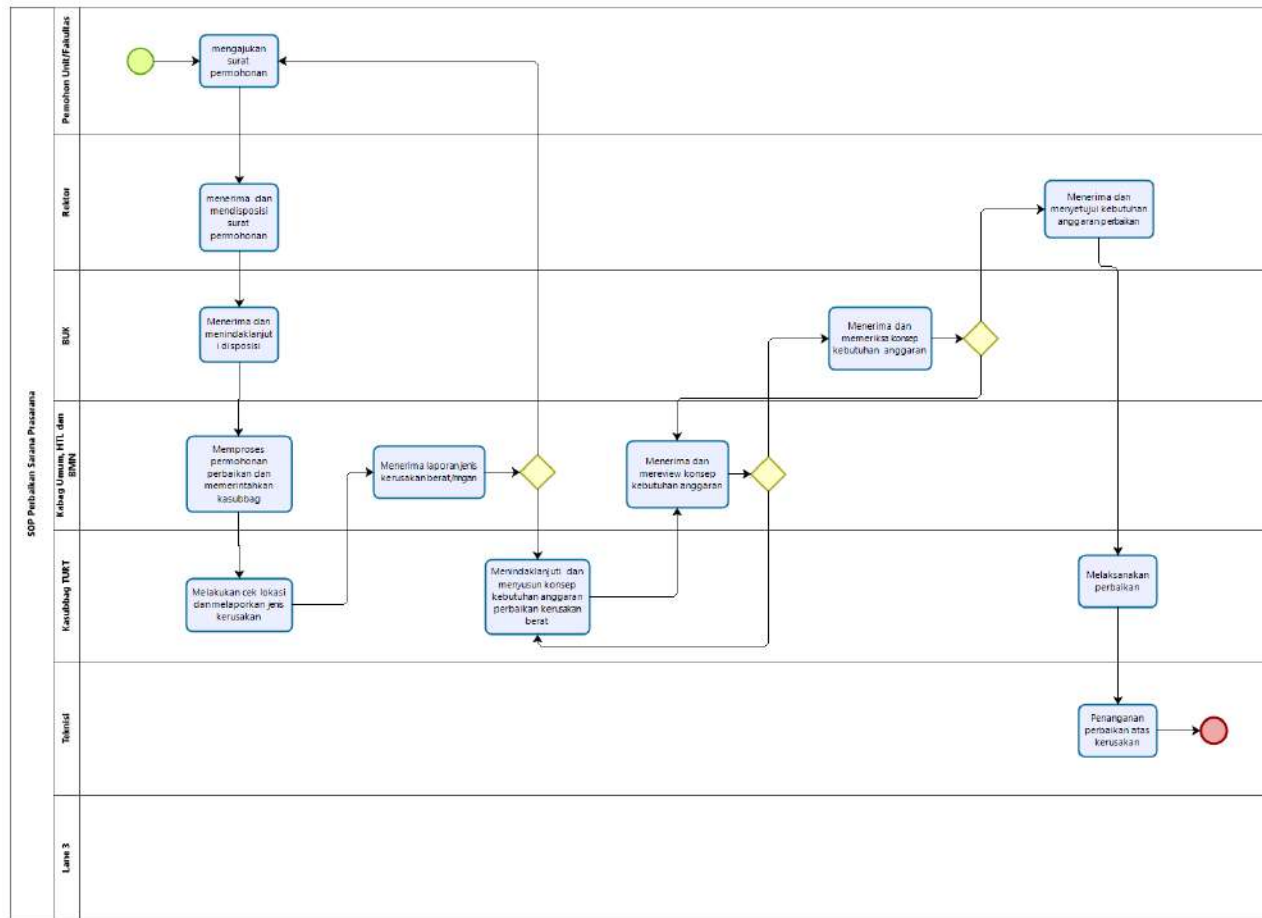



# 175 SOP Perkuliahan Reguler

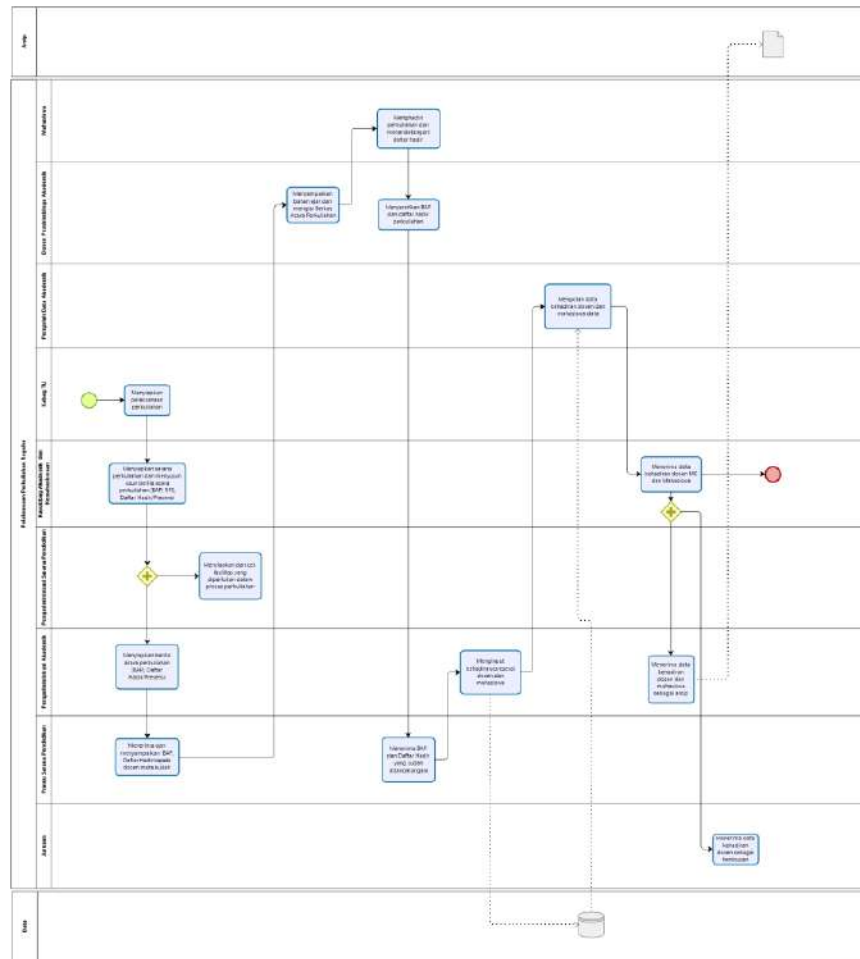



## 176 SOP Permohonan Penurunan UKT

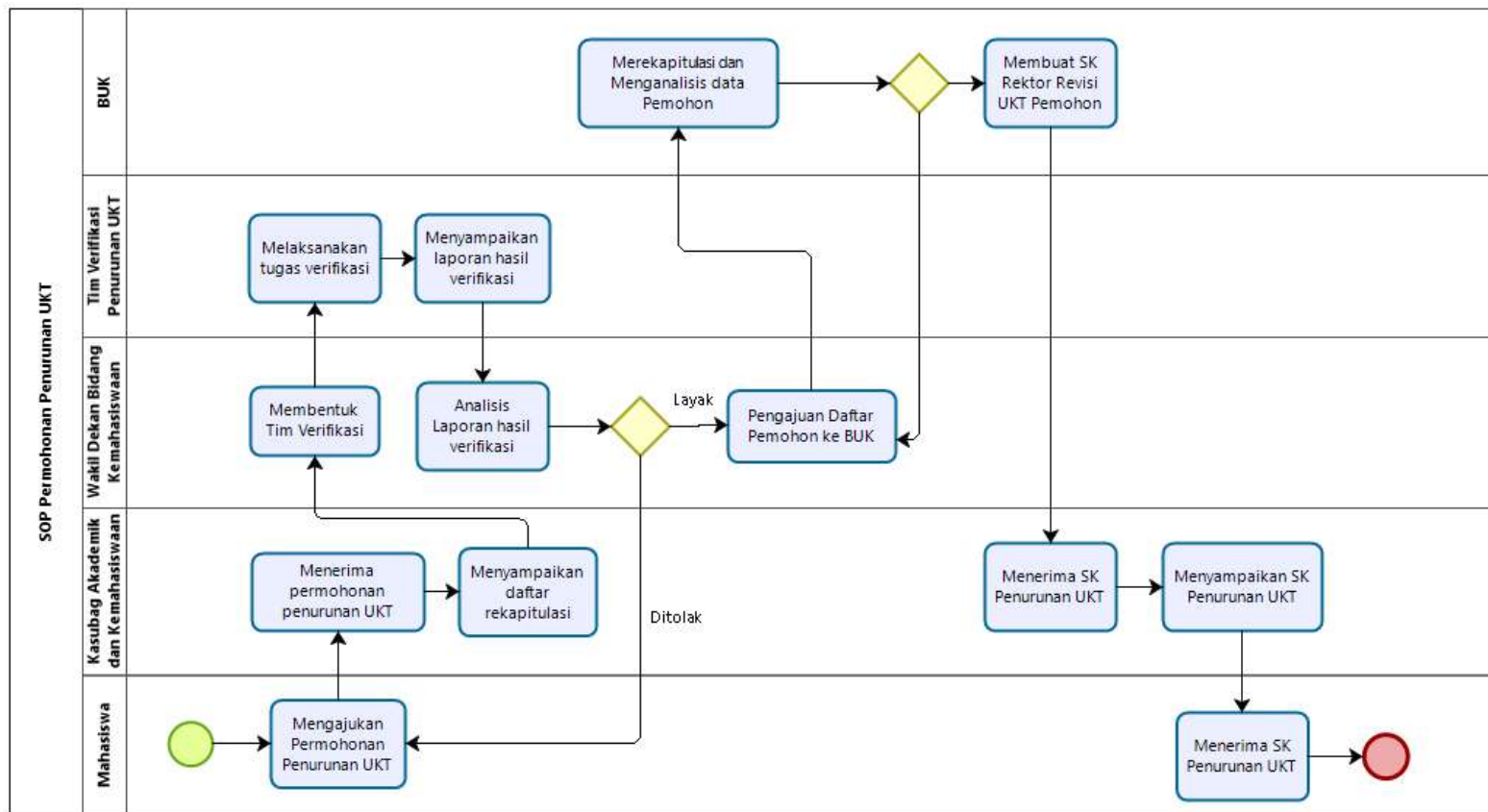



## 177 SOP Pertanggungjawaban UP dan TUP

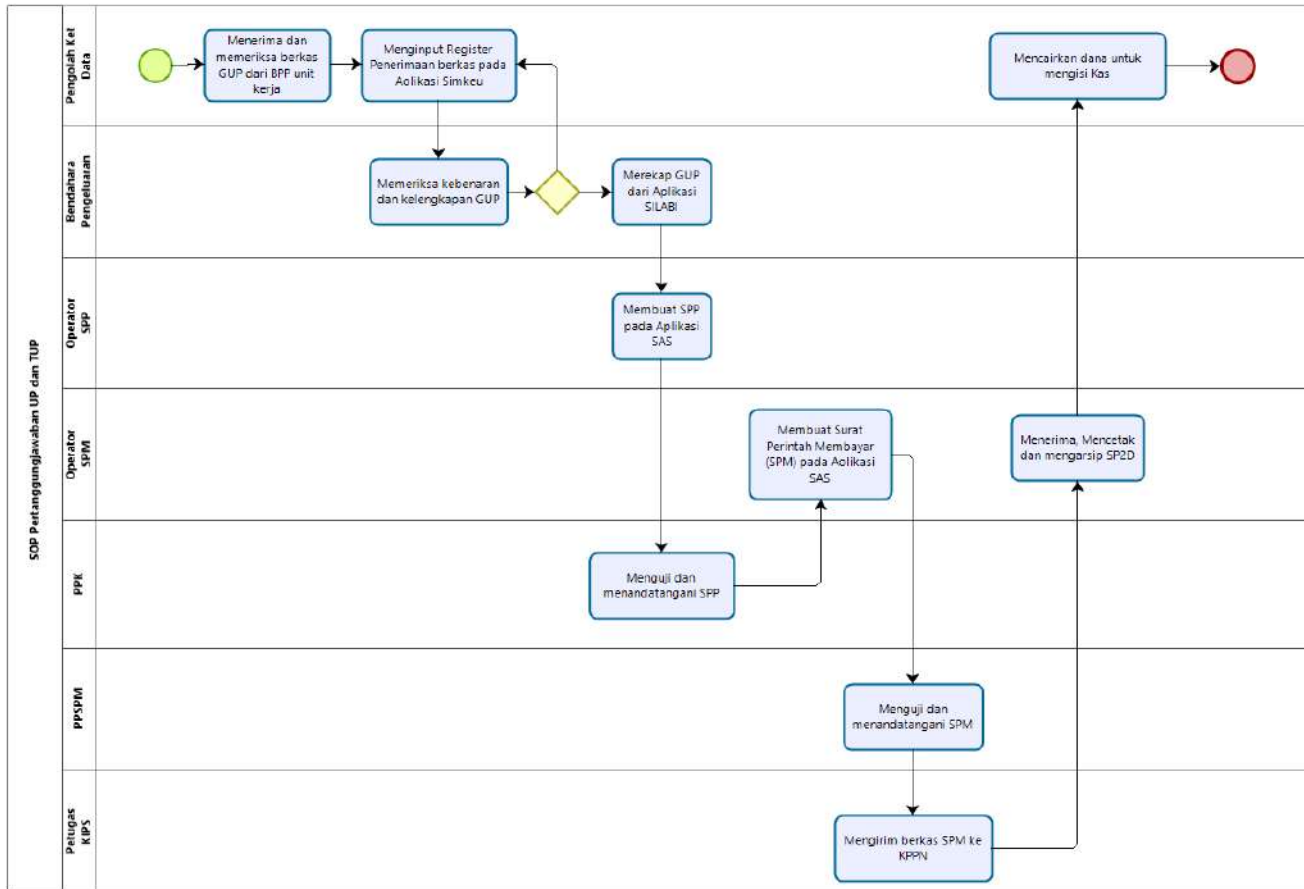



# 178 SOP Pindah Ke PT Lain

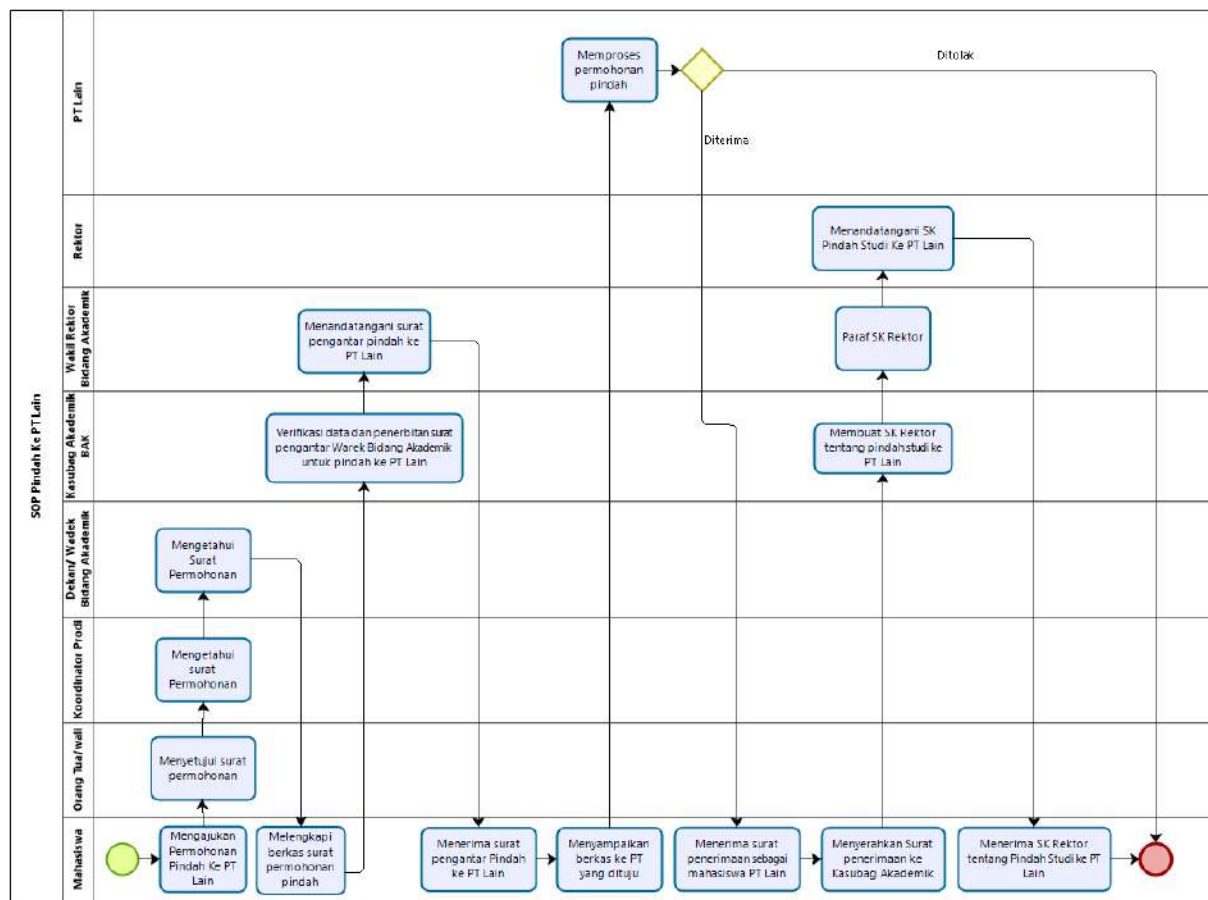



# 179 SOP Pindah Prodi Dari PT Lain

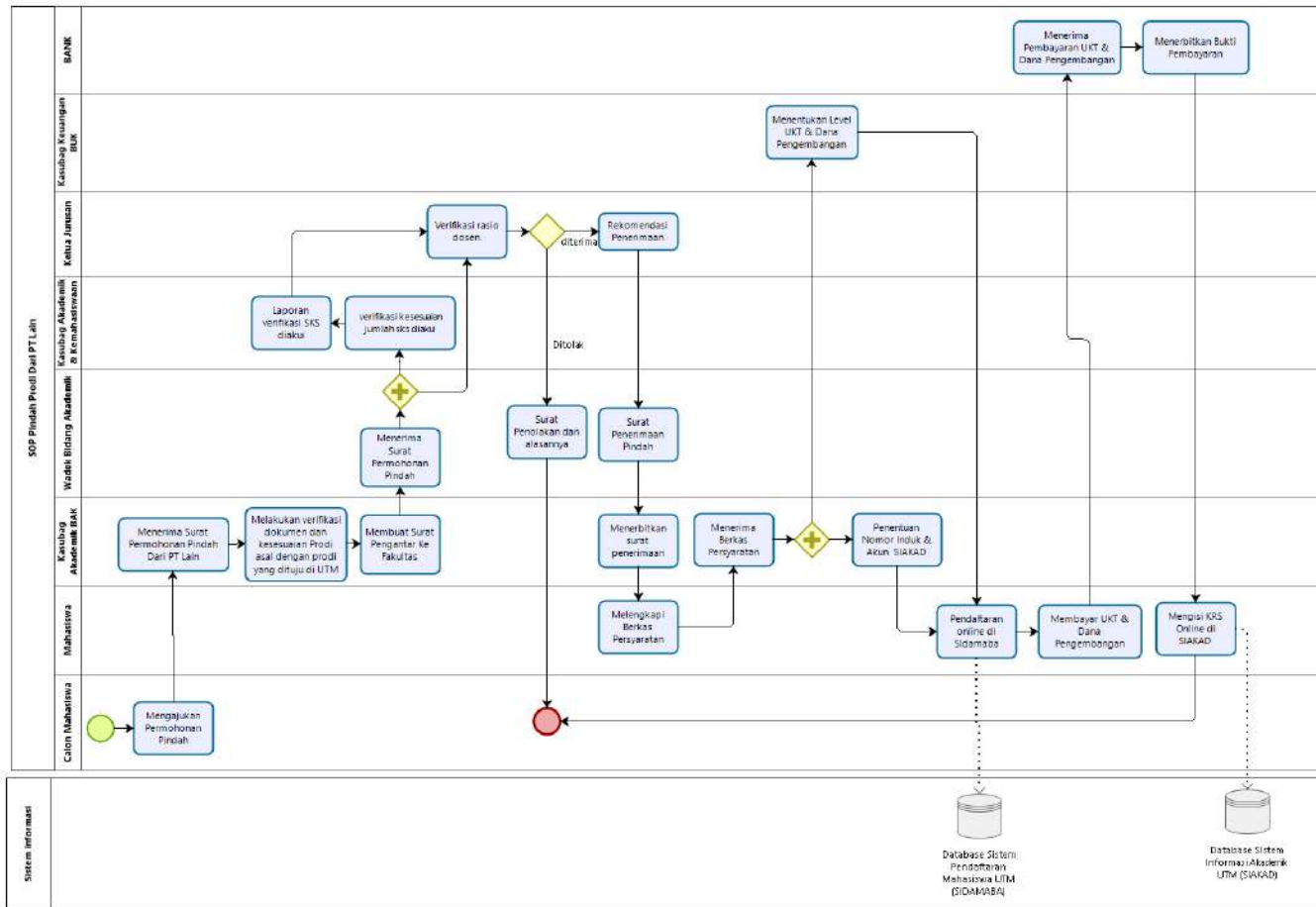



## 180 SOP Pindah Prodi Diluar UTM

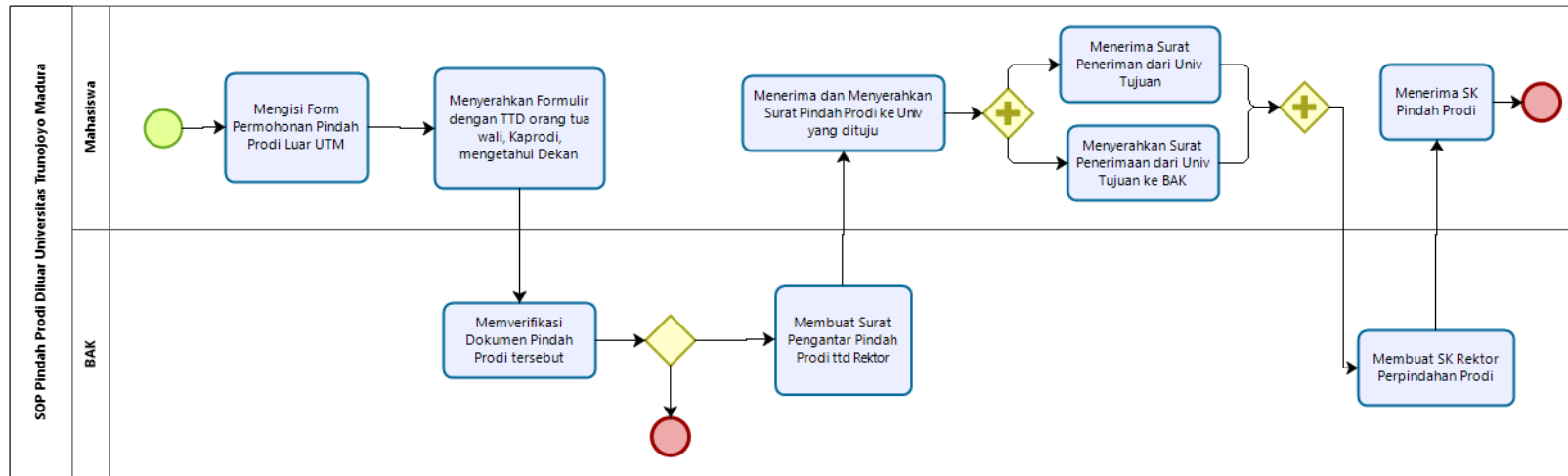



# 181 SOP Pindah Prodi Lintas Fakultas

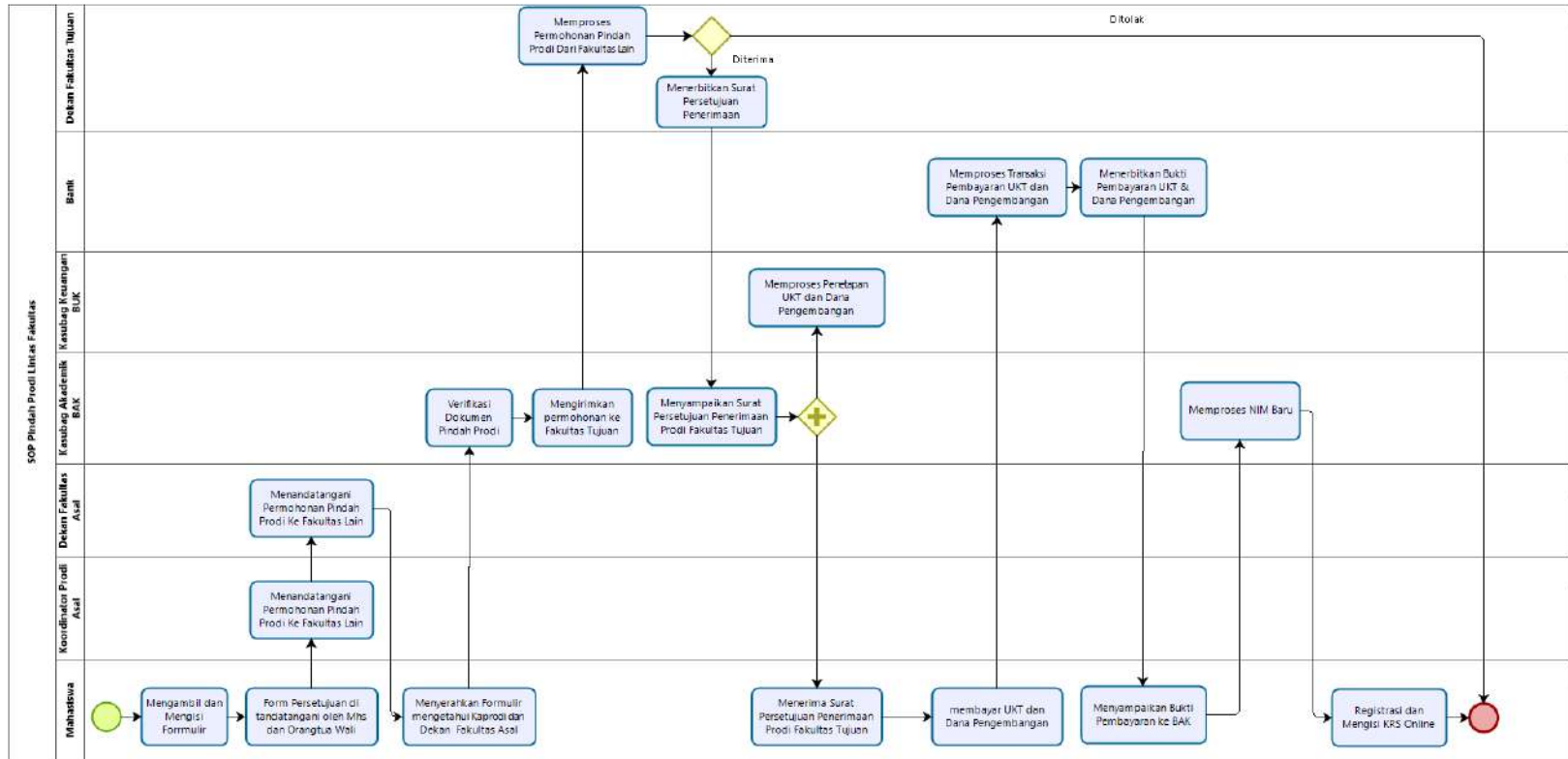





## 182 SOP Pindah Prodi Satu Fakultas

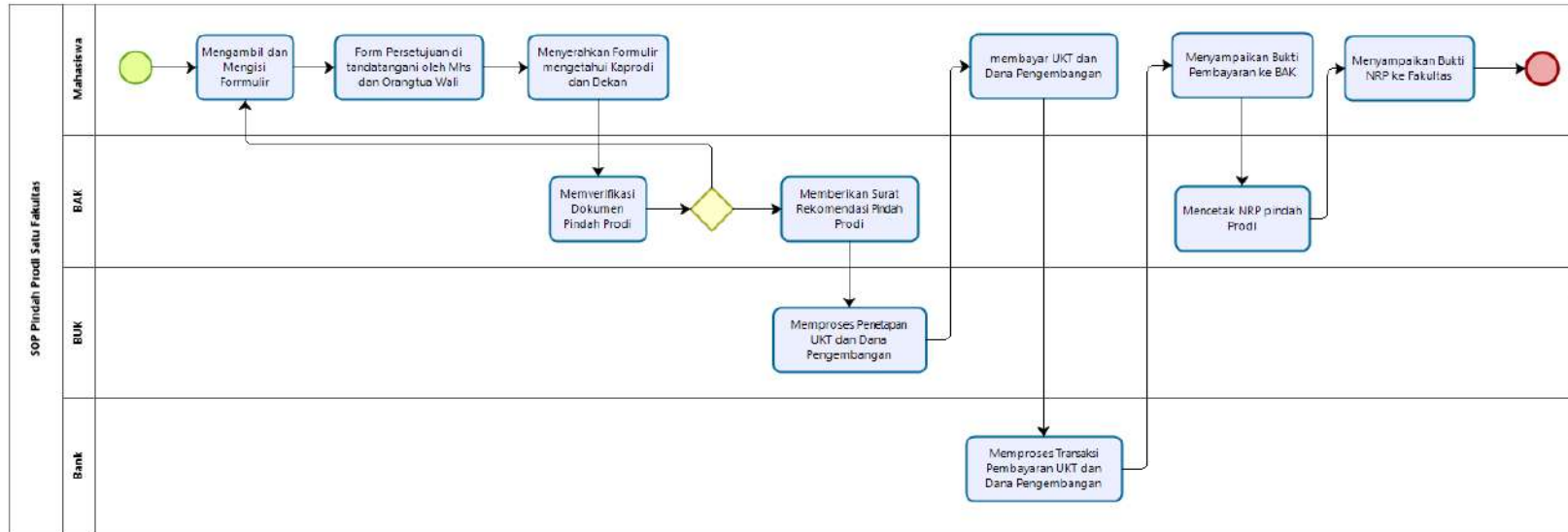



# 183 SOP Praktek Kerja Lapangan

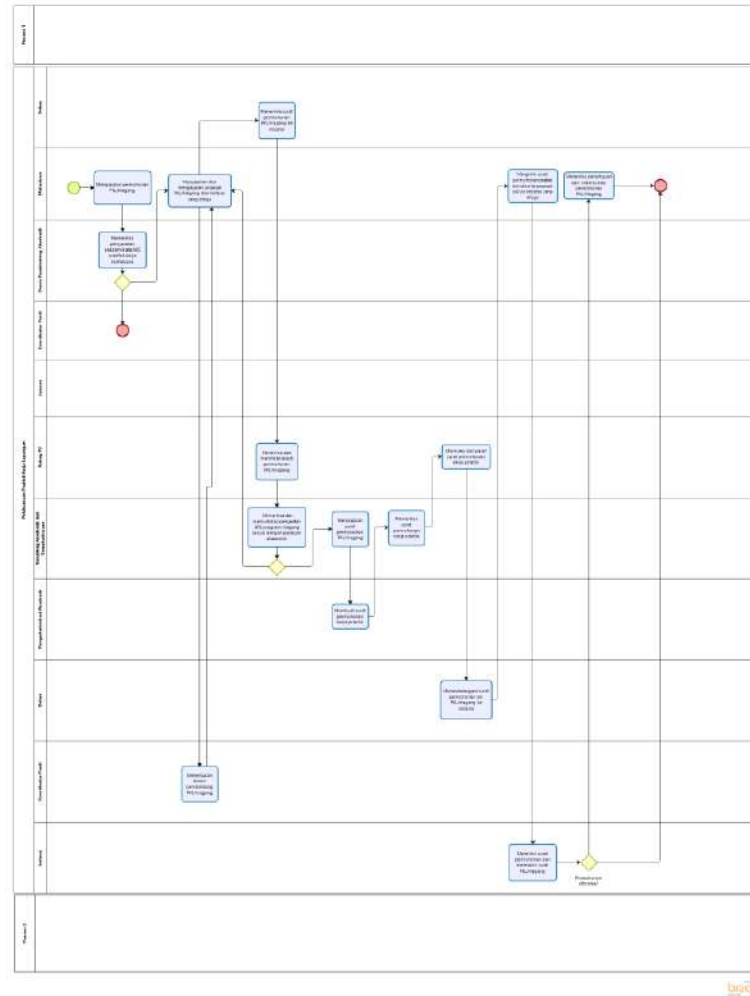



# 184 SOP Praktikum

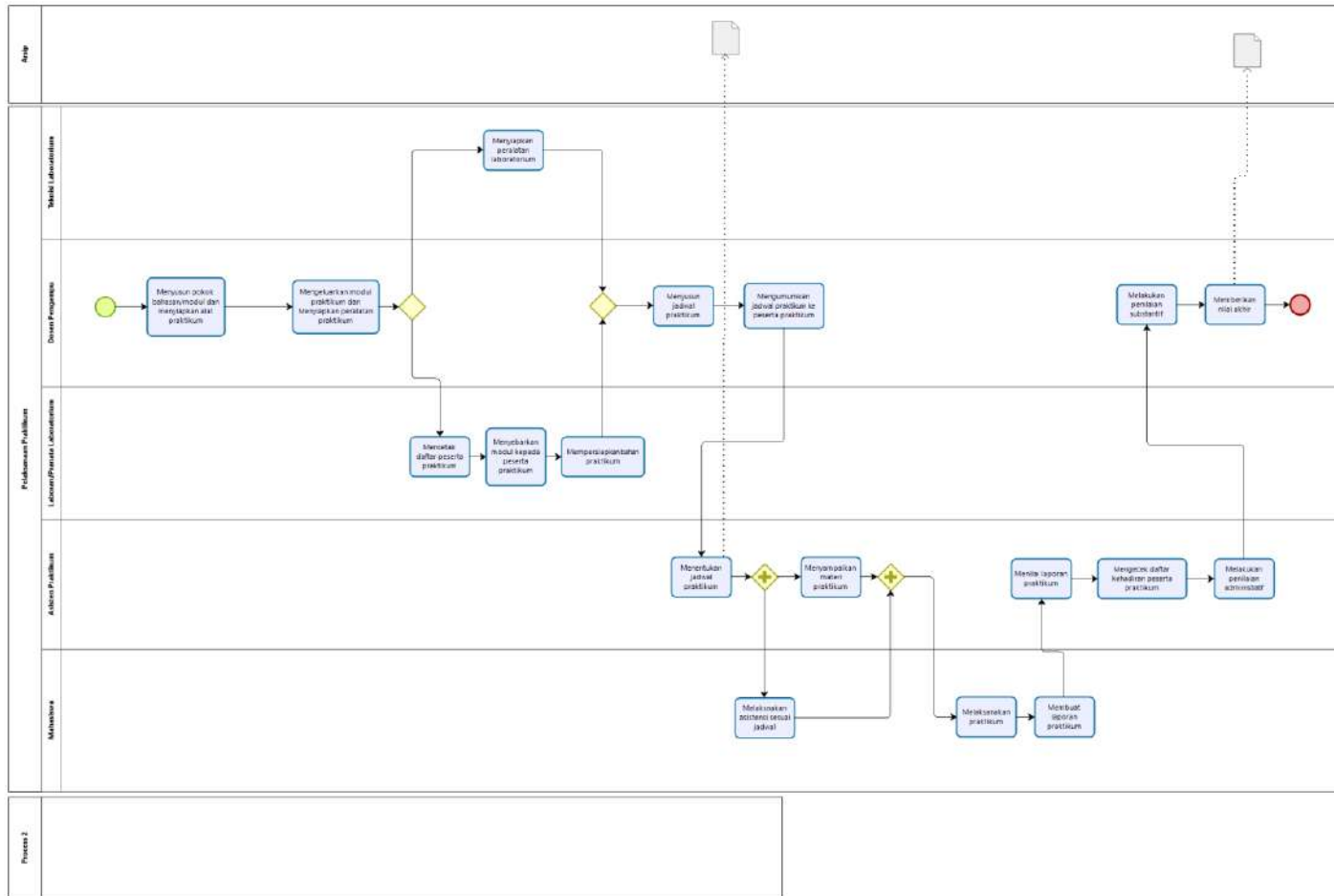



## 185 SOP Preventive Maintenance Perangkat

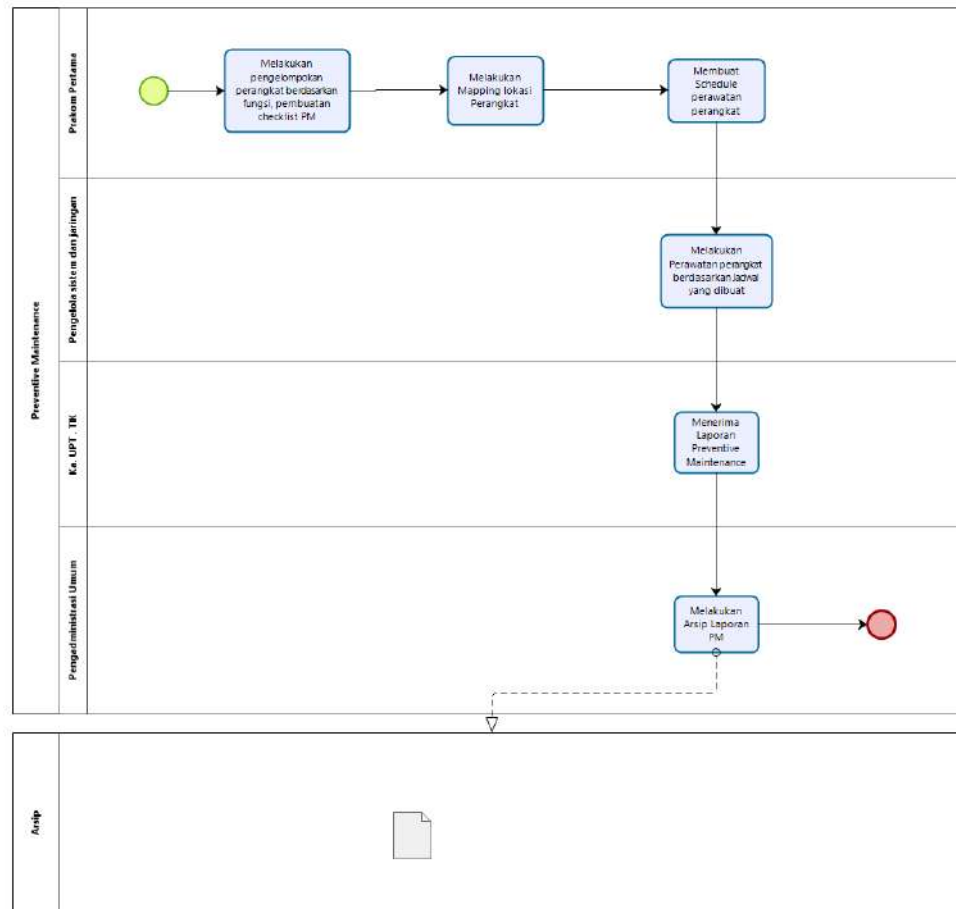



## 186 SOP Publikasi Hasil Penelitian Abdimas di Jurnal/Prosiding Lainnya

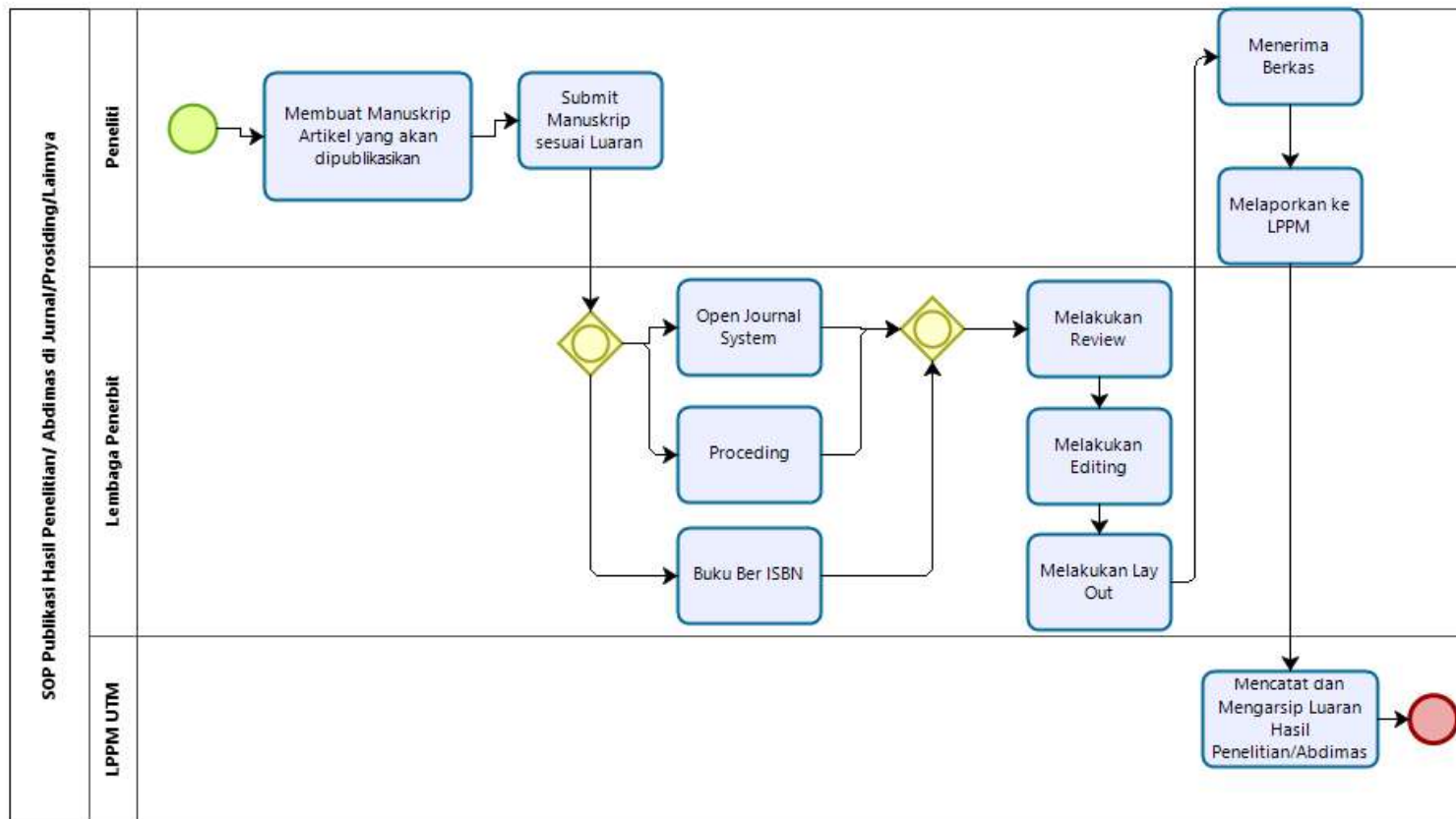



## 187 SOP Registrasi Mahasiswa Baru Jalur Mandiri

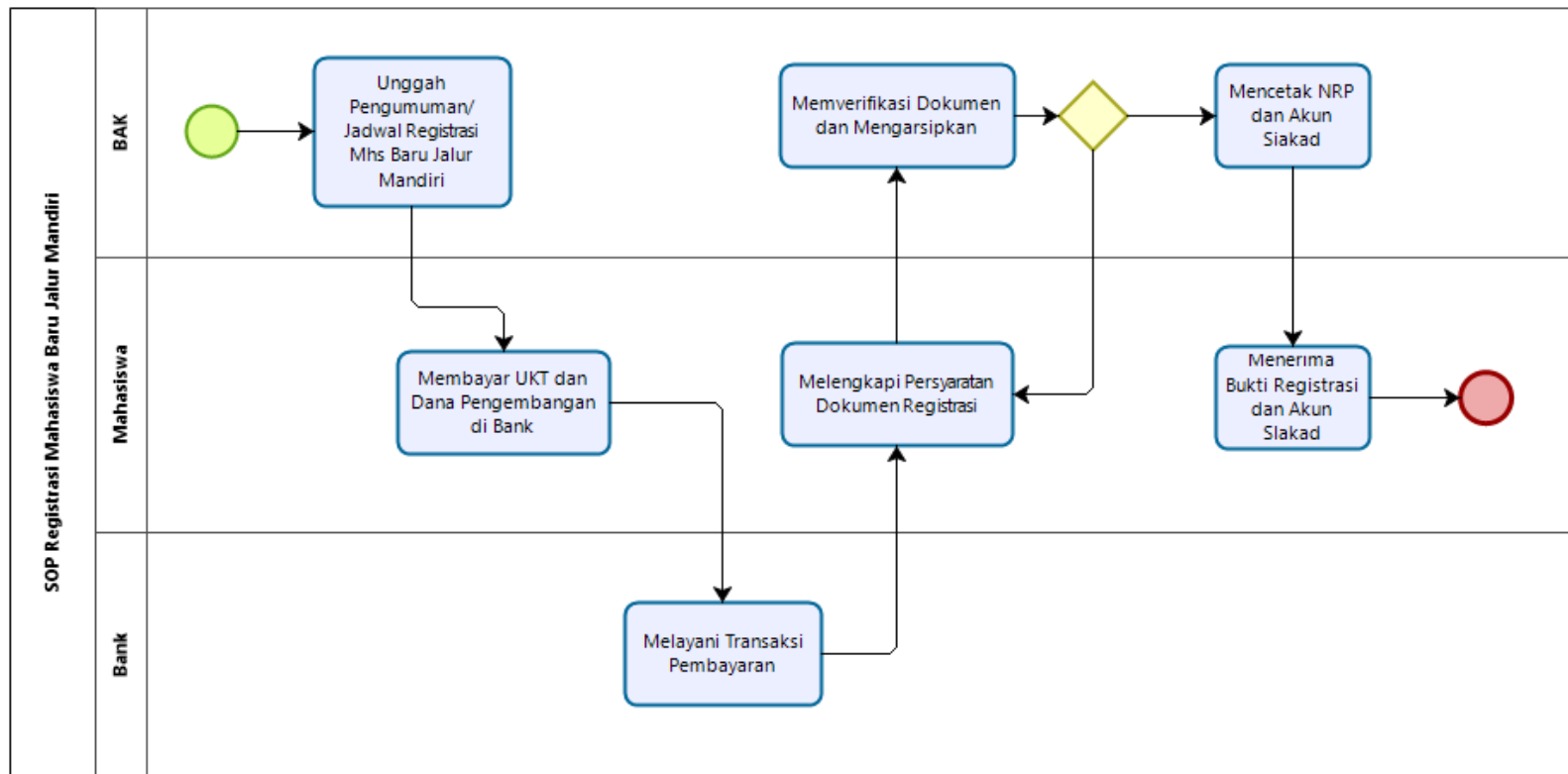



## 188 SOP Registrasi Mhs Baru jalur SBMPTN

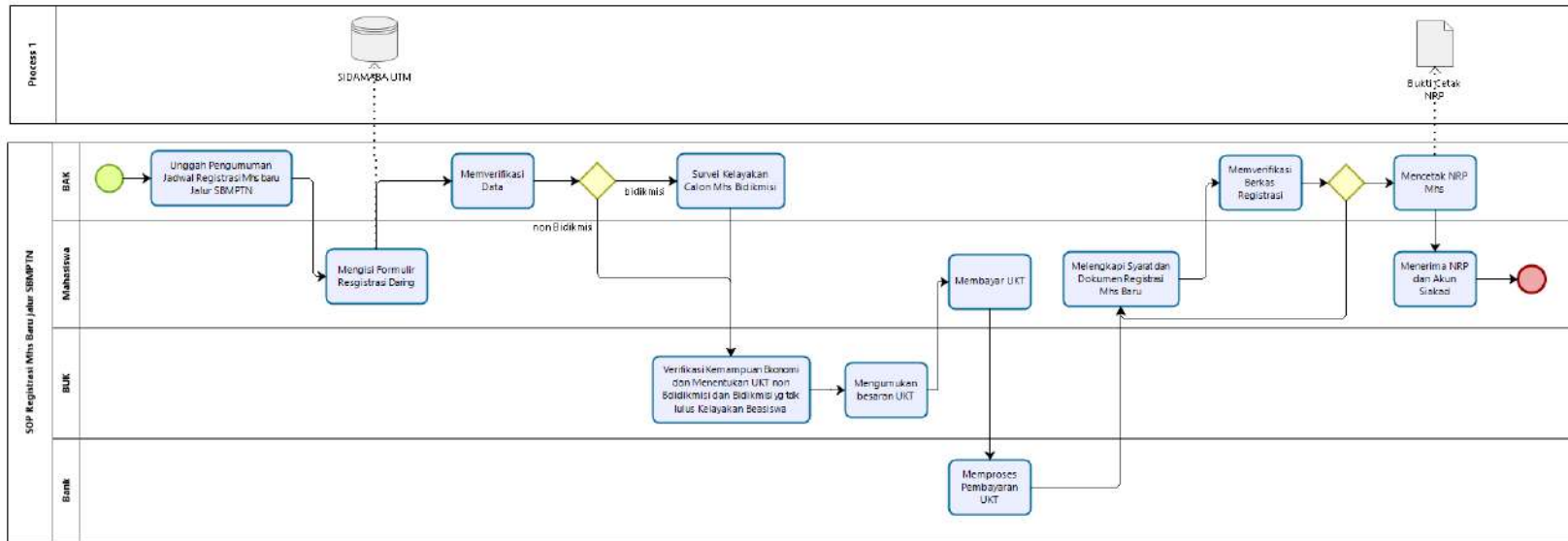



## 189 SOP Registrasi Mhs Baru jalur SNMPTN

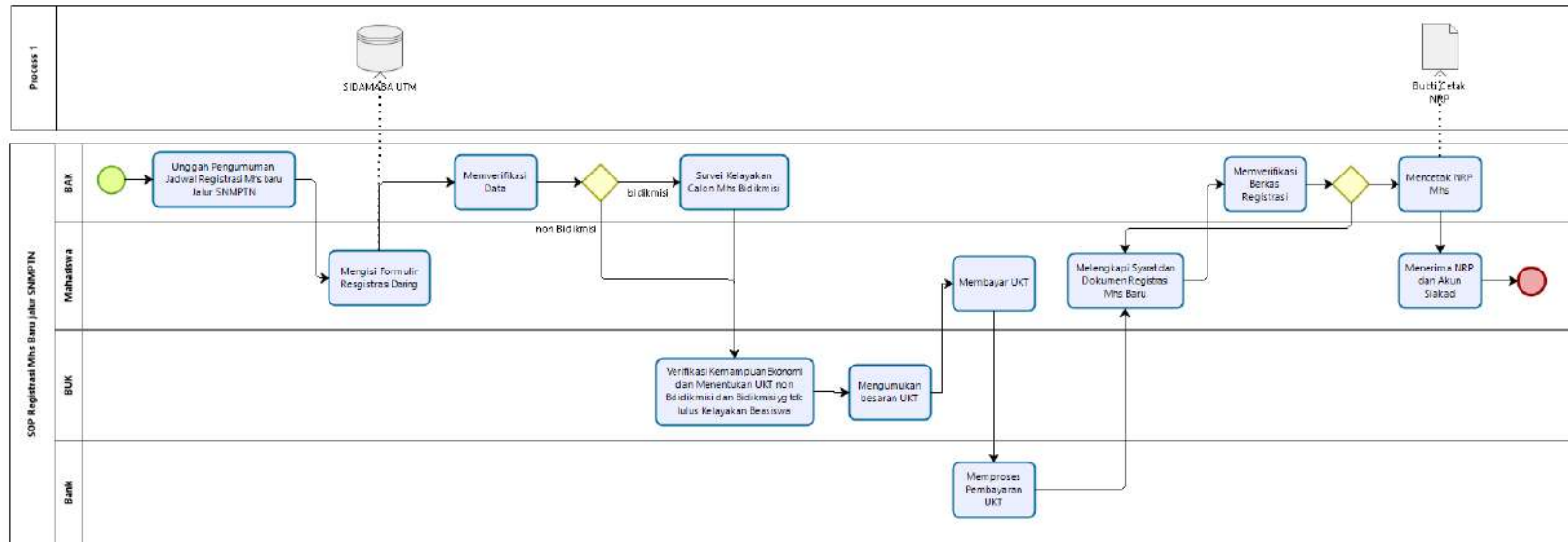





## 190 SOP Registrasi Online (SIKAD)

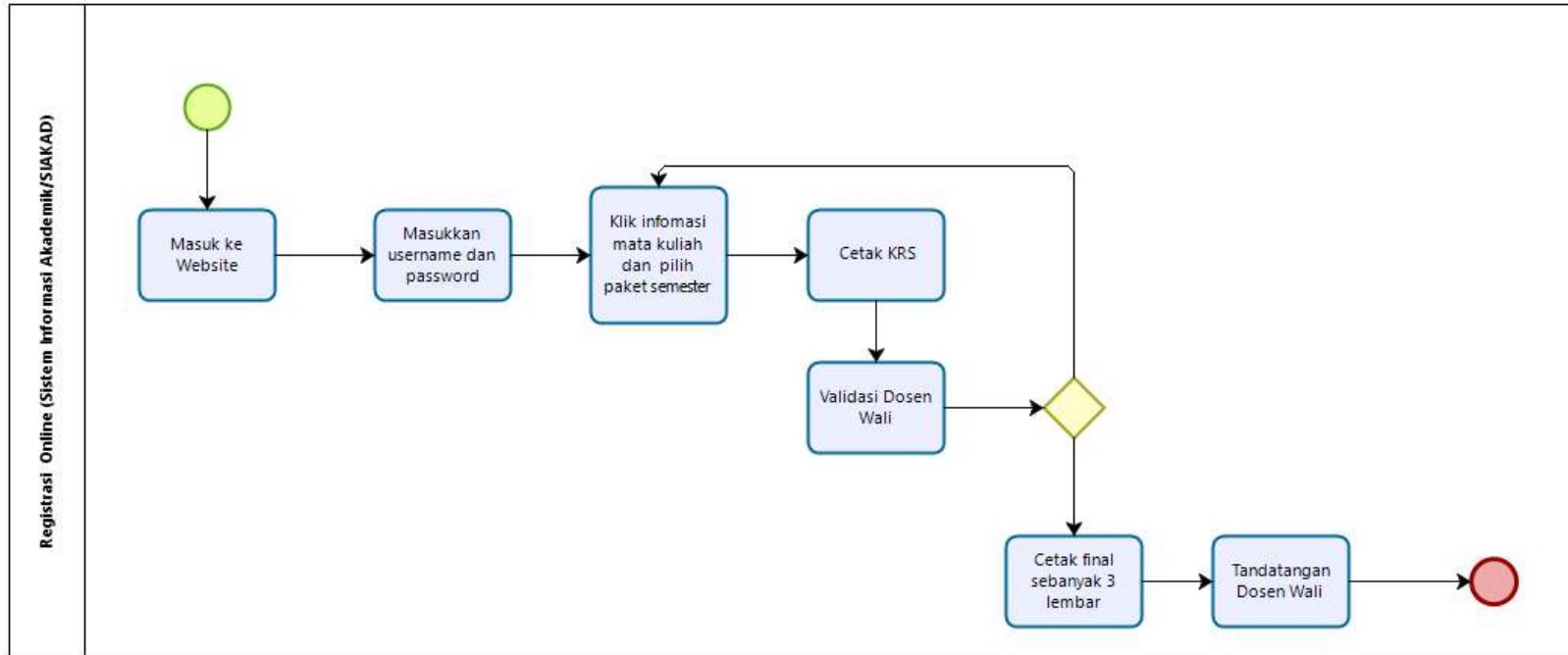



# 191 SOP Revisi RKAKL

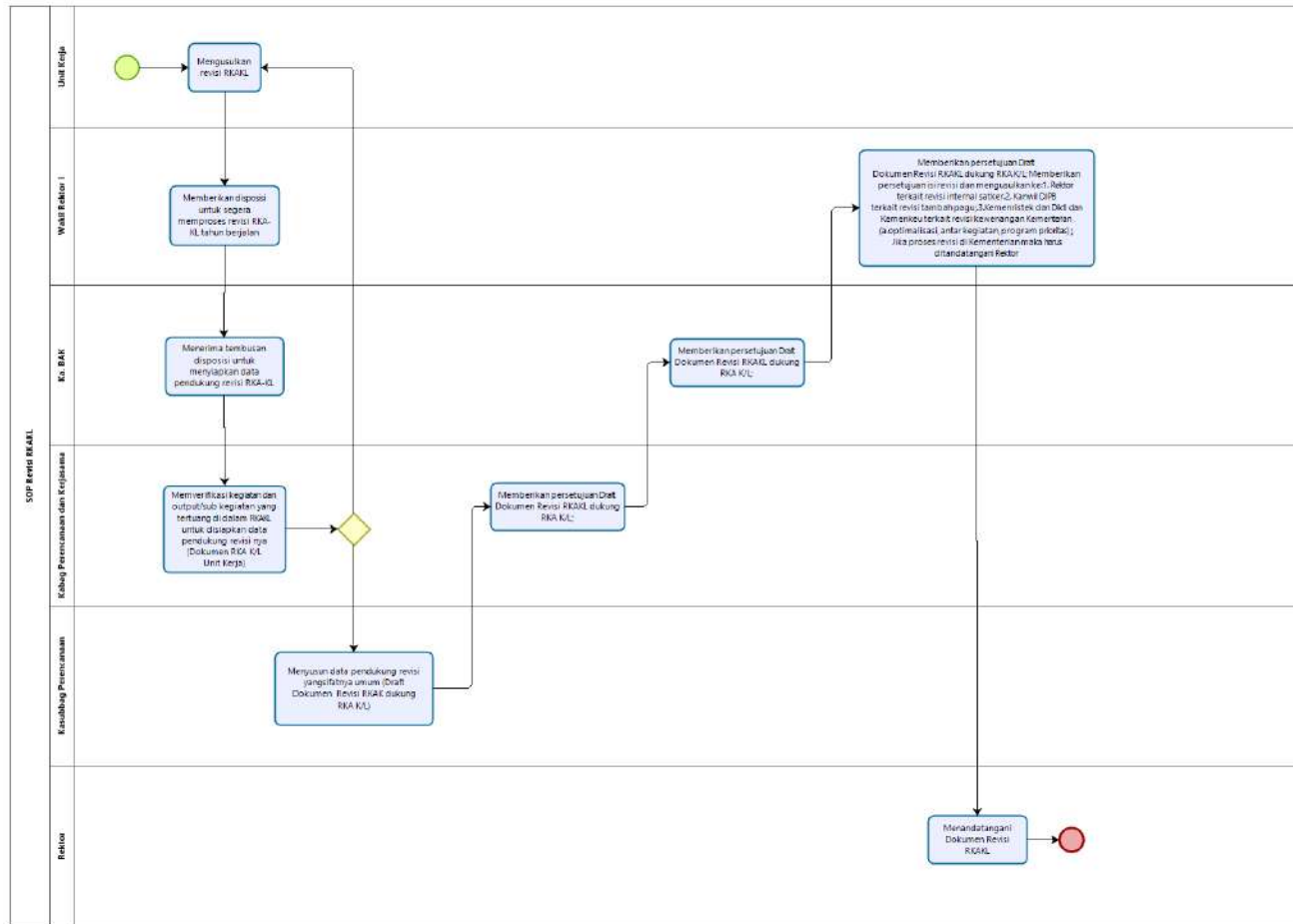



# 192 SOP RKAKL DIPA

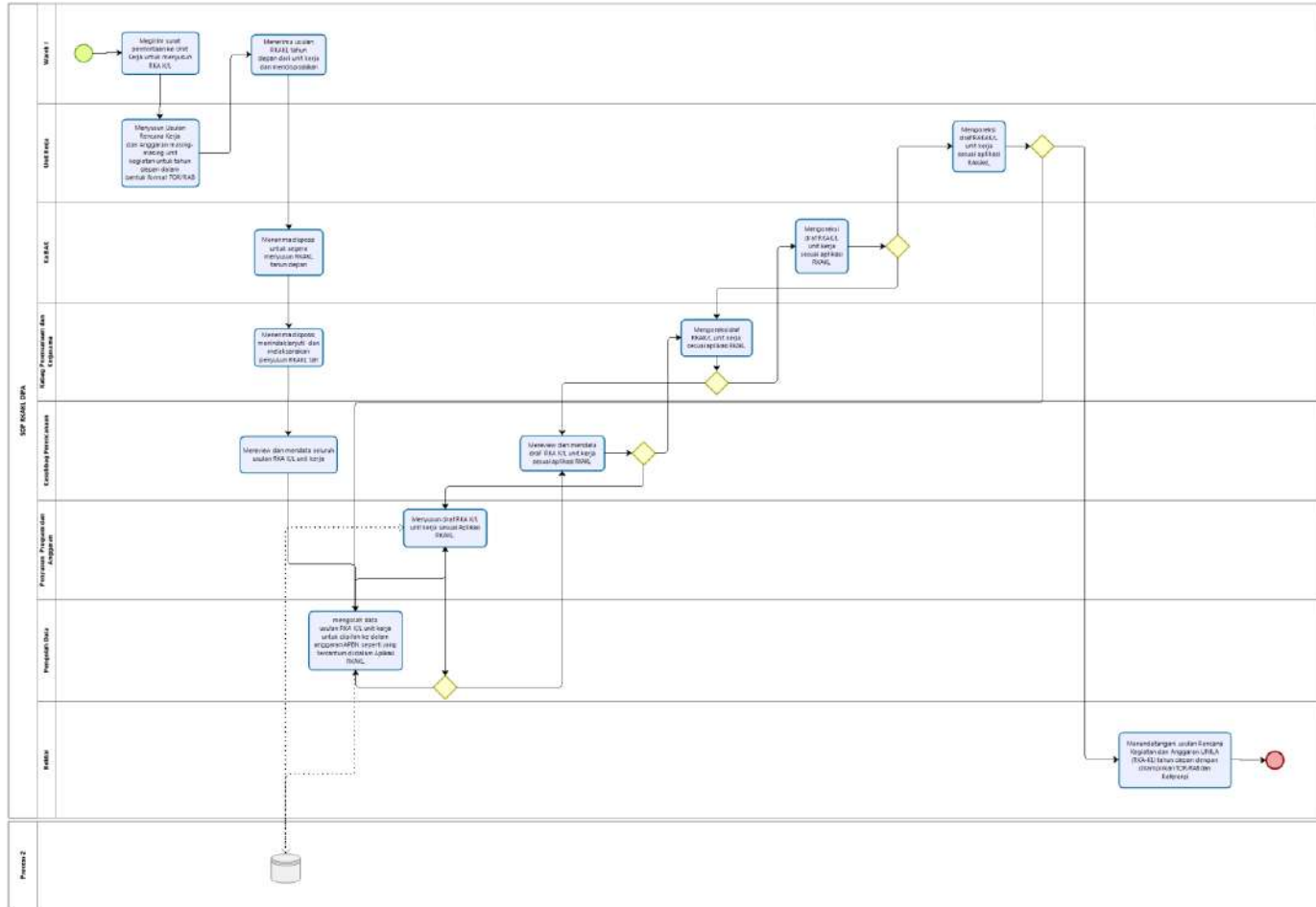



## 193 SOP Seleksi Penunjukan Abdimas

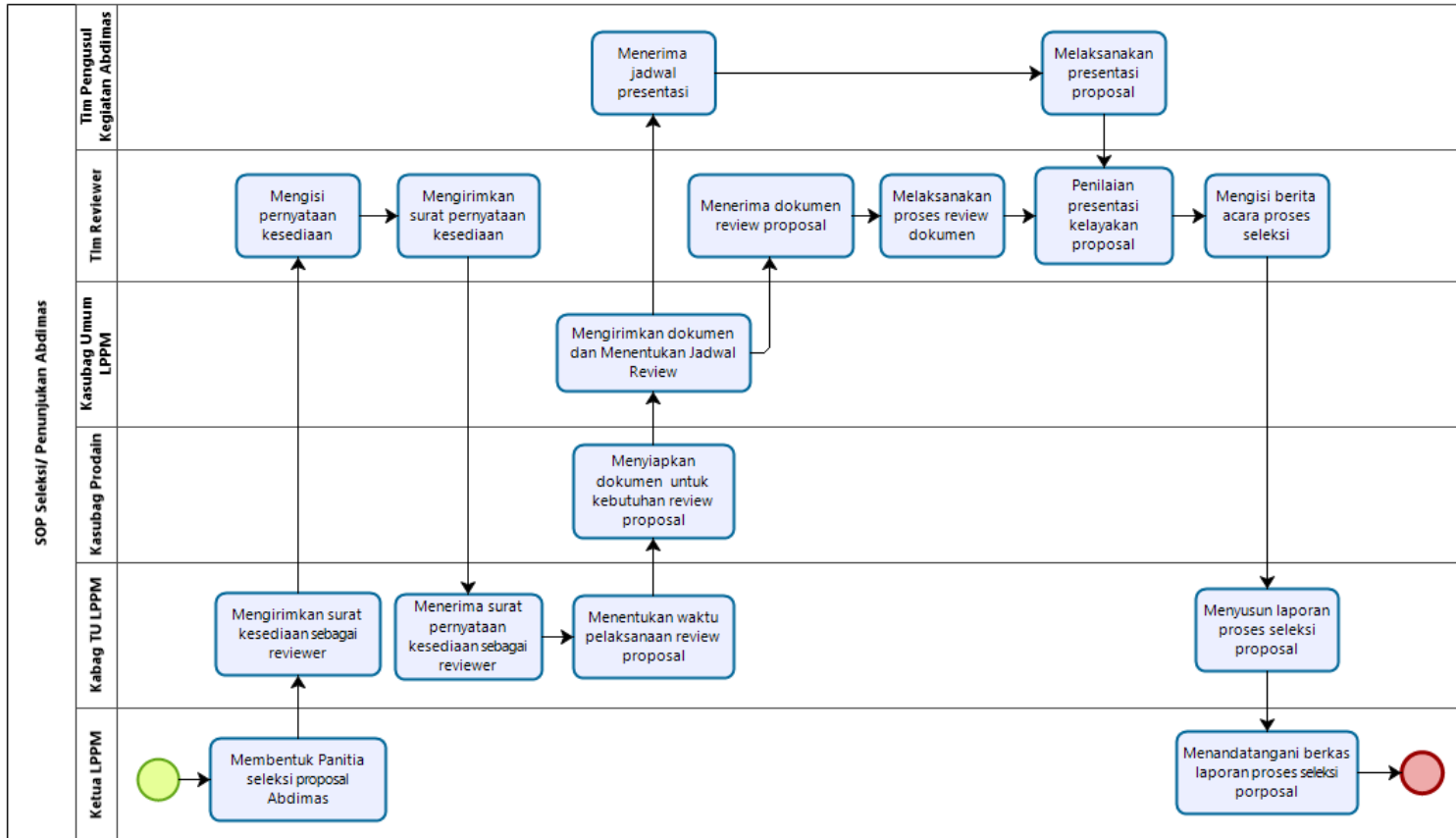



# 194 SOP Seleksi Penunjukan Penelitian

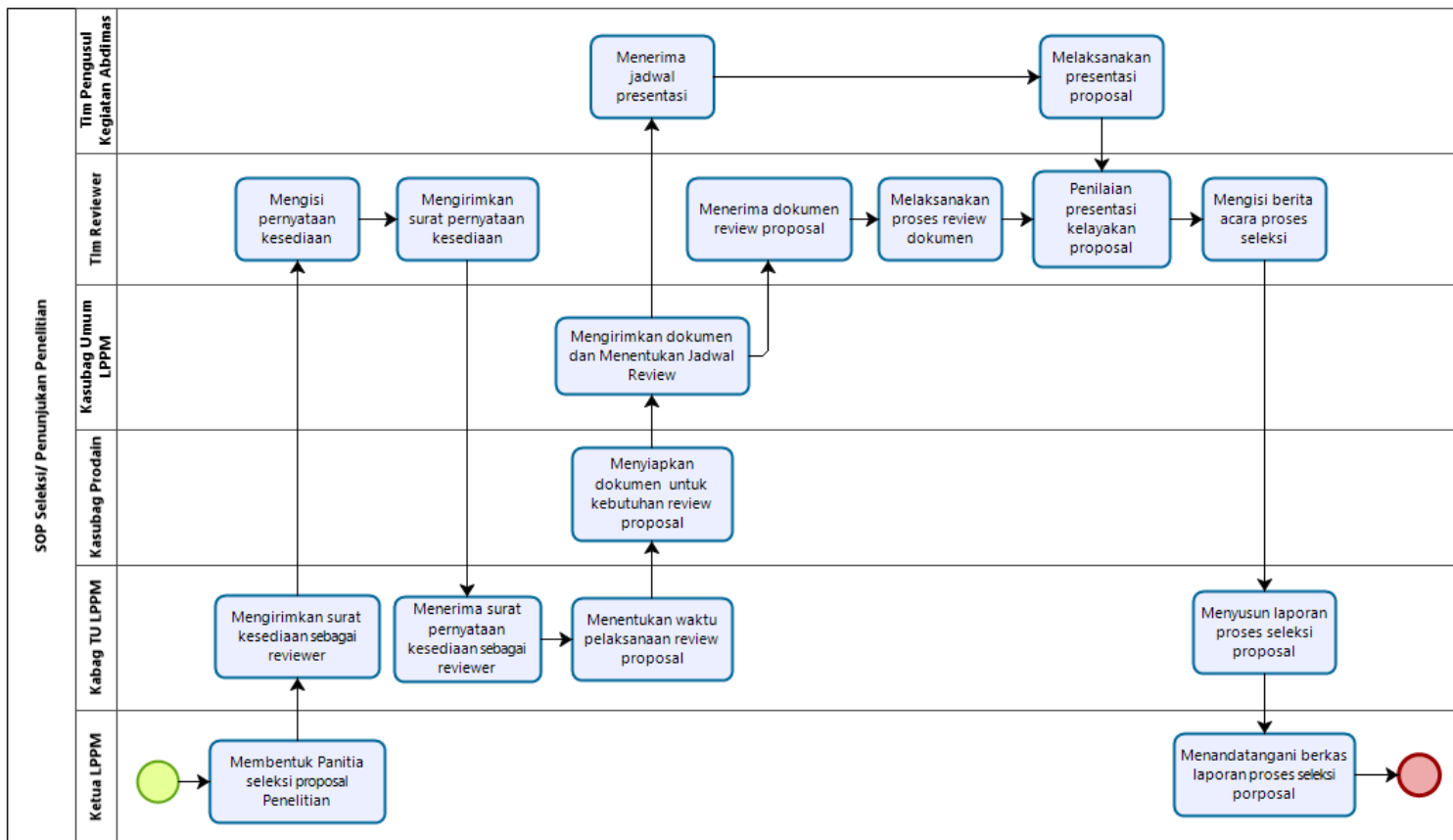



# 195 SOP Seminar Proposal Tugas Akhir

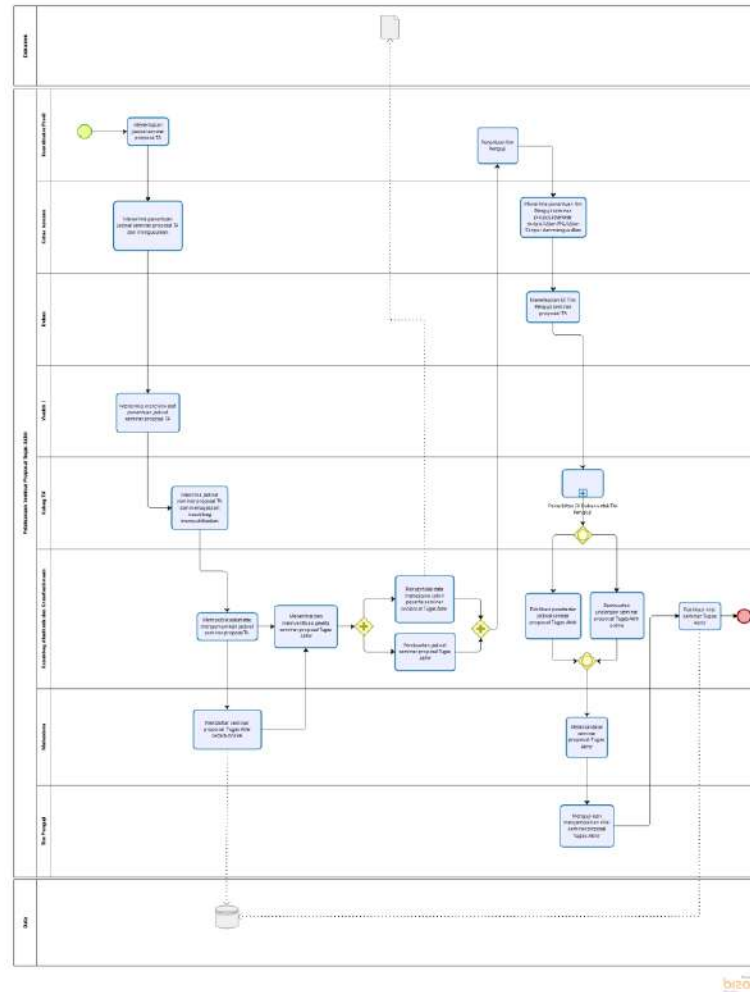



# 196 SOP Serah Terima dan Pelantikan

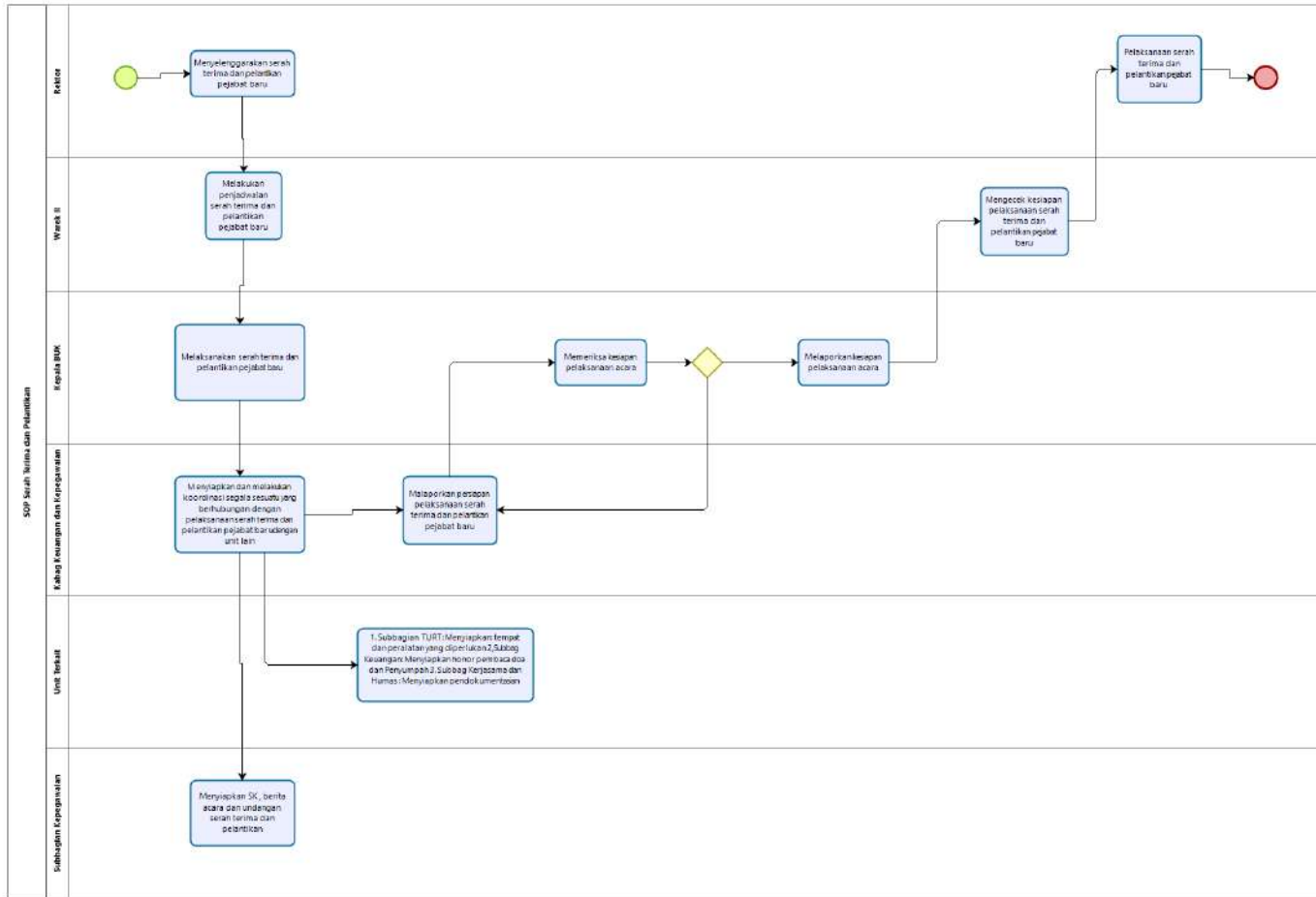



# 197 SOP Surat Ijin Tidak Masuk Kuliah (Dispensasi) Kegiatan di Luar Kampus

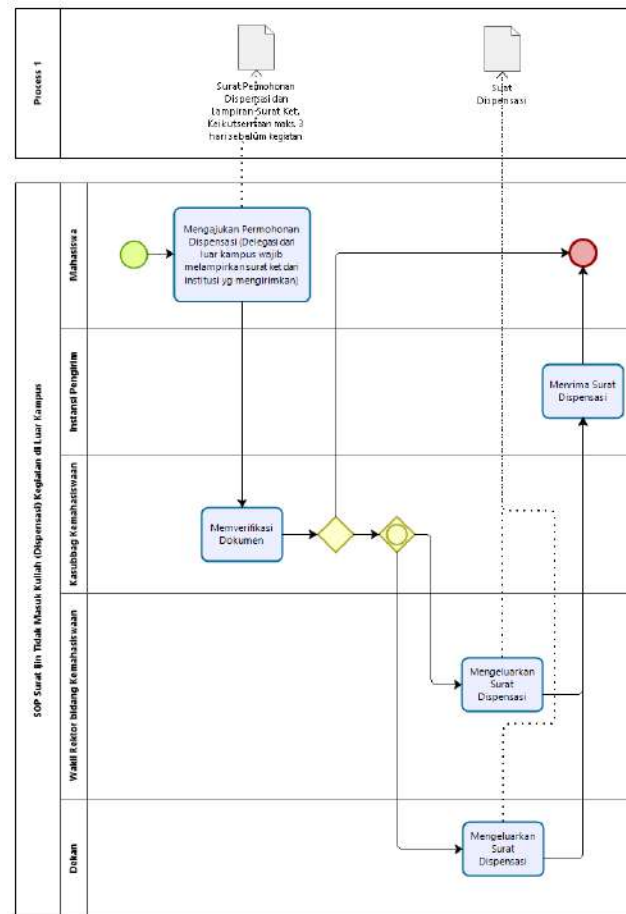





# 198 SOP Surat Ijin Tidak Masuk Kuliah (Dispensasi) Melakukan Kegiatan di dalam Kampus

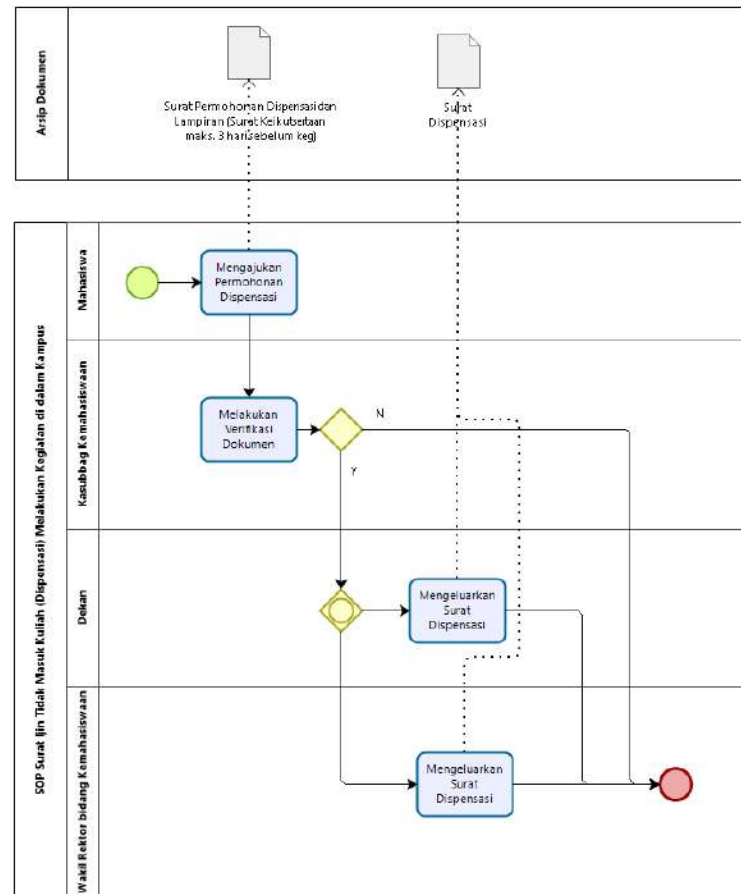

Powered by bizagi Model



# 199 SOP Surat Keluar Fakultas

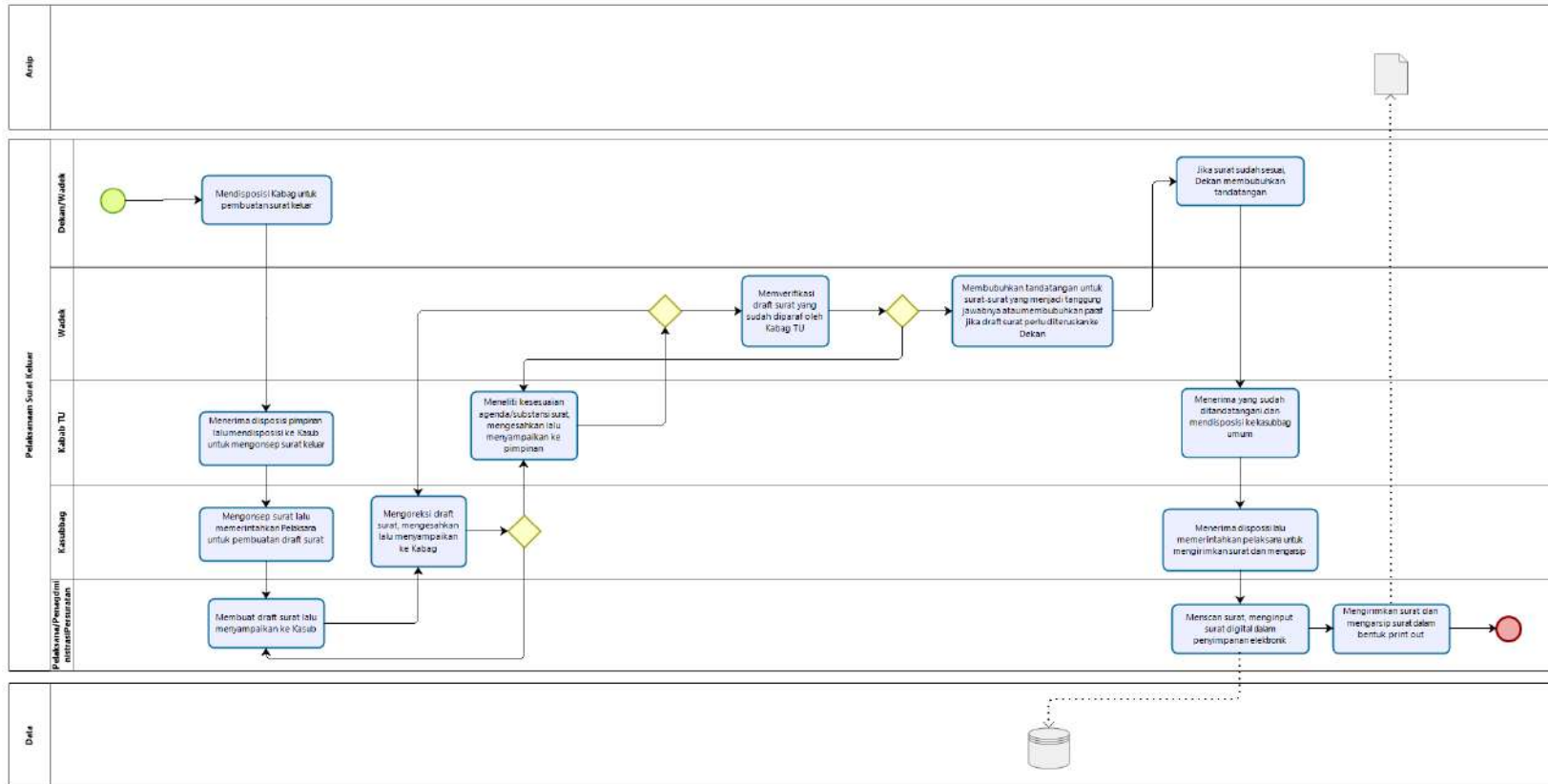



## 200 SOP Surat Keluar pimpinan

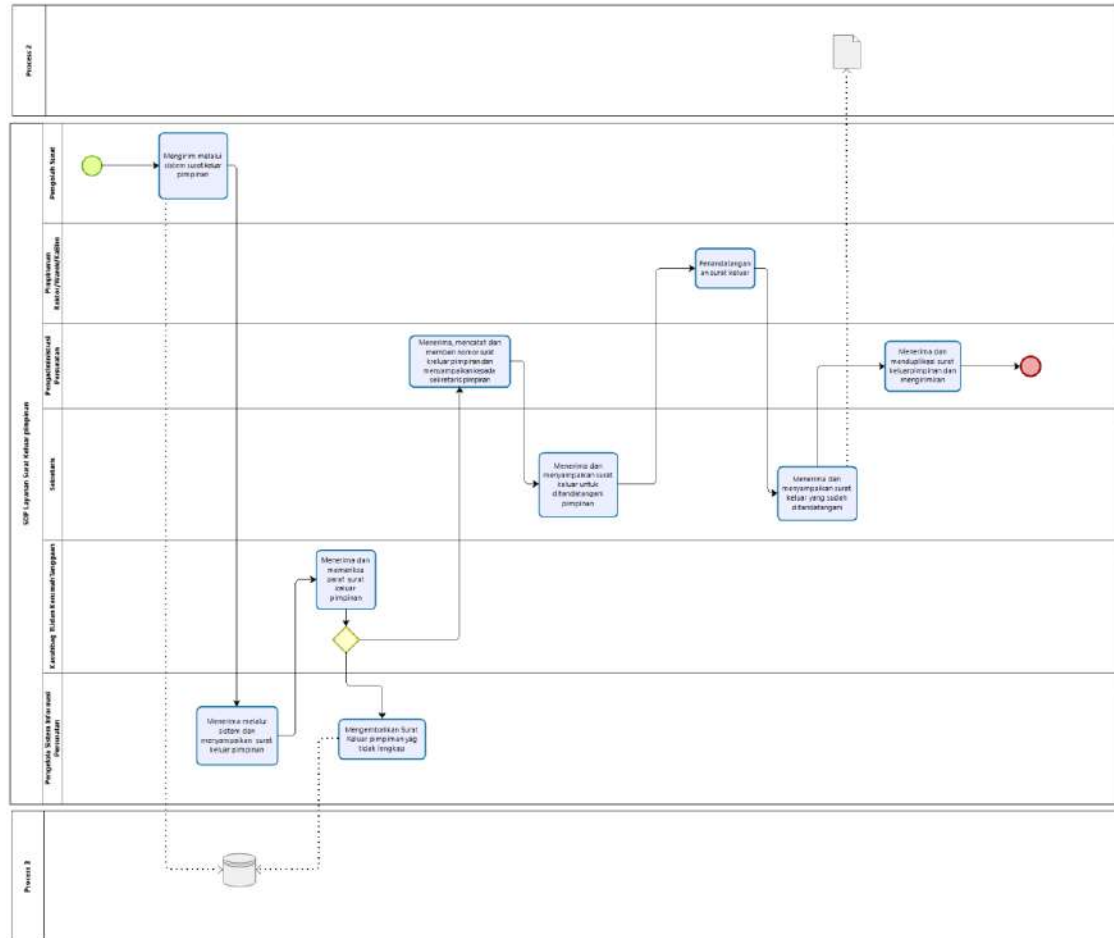



## 201 SOP Surat Masuk Fakultas

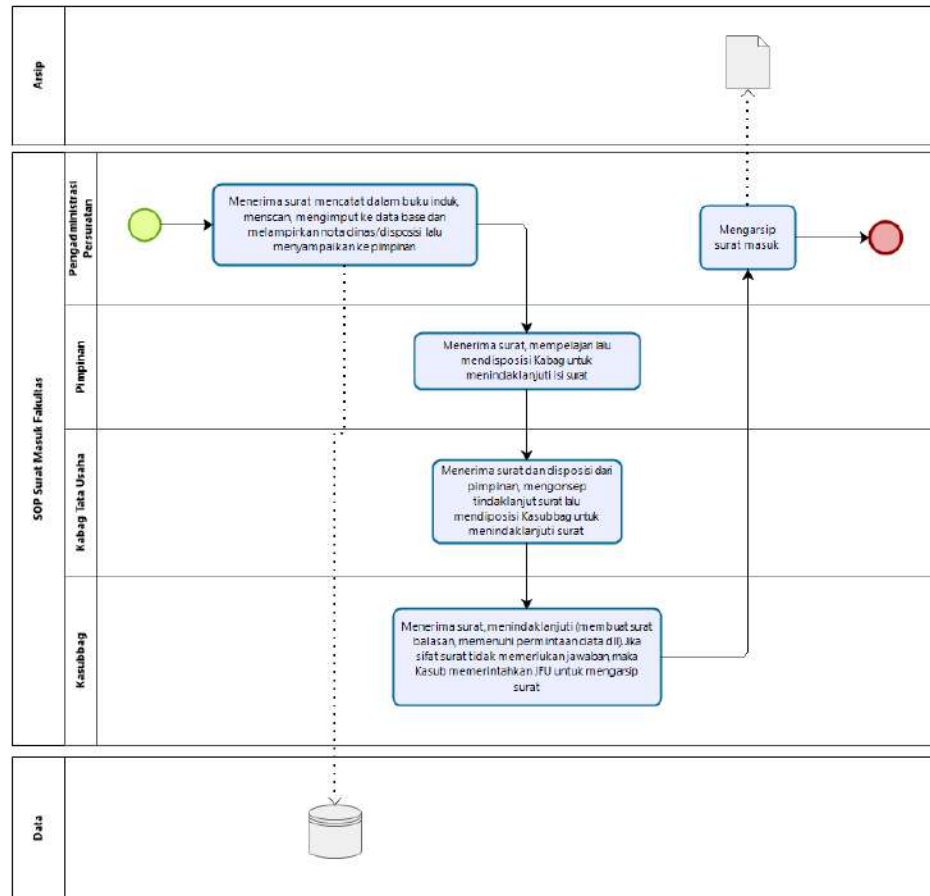



## 202 SOP Surat Masuk Pimpinan

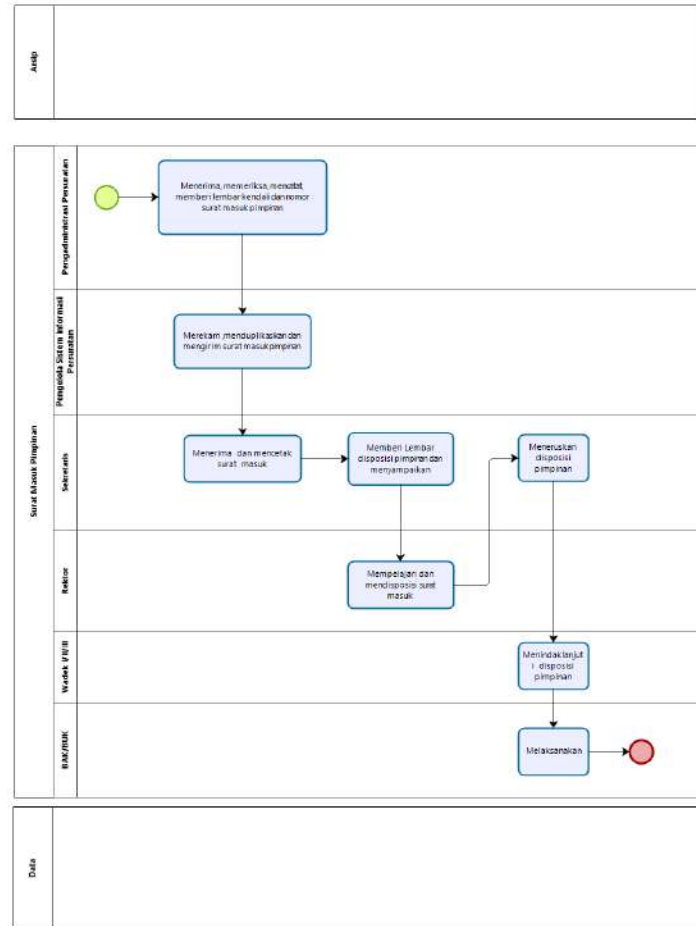



## 203 SOP Test of English as a Foreign Language (TOEFL)

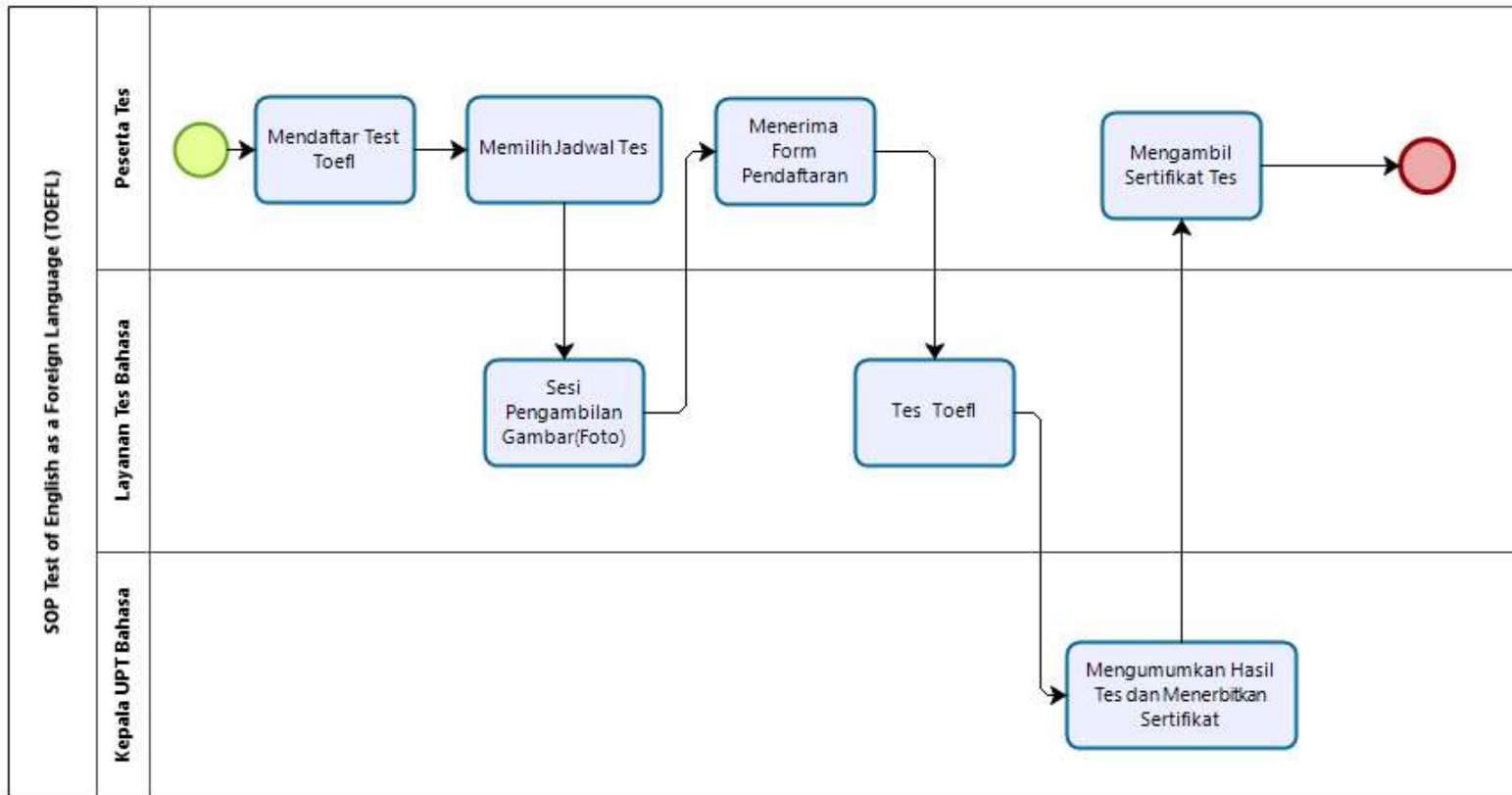



## 204 SOP Tindak Lanjut

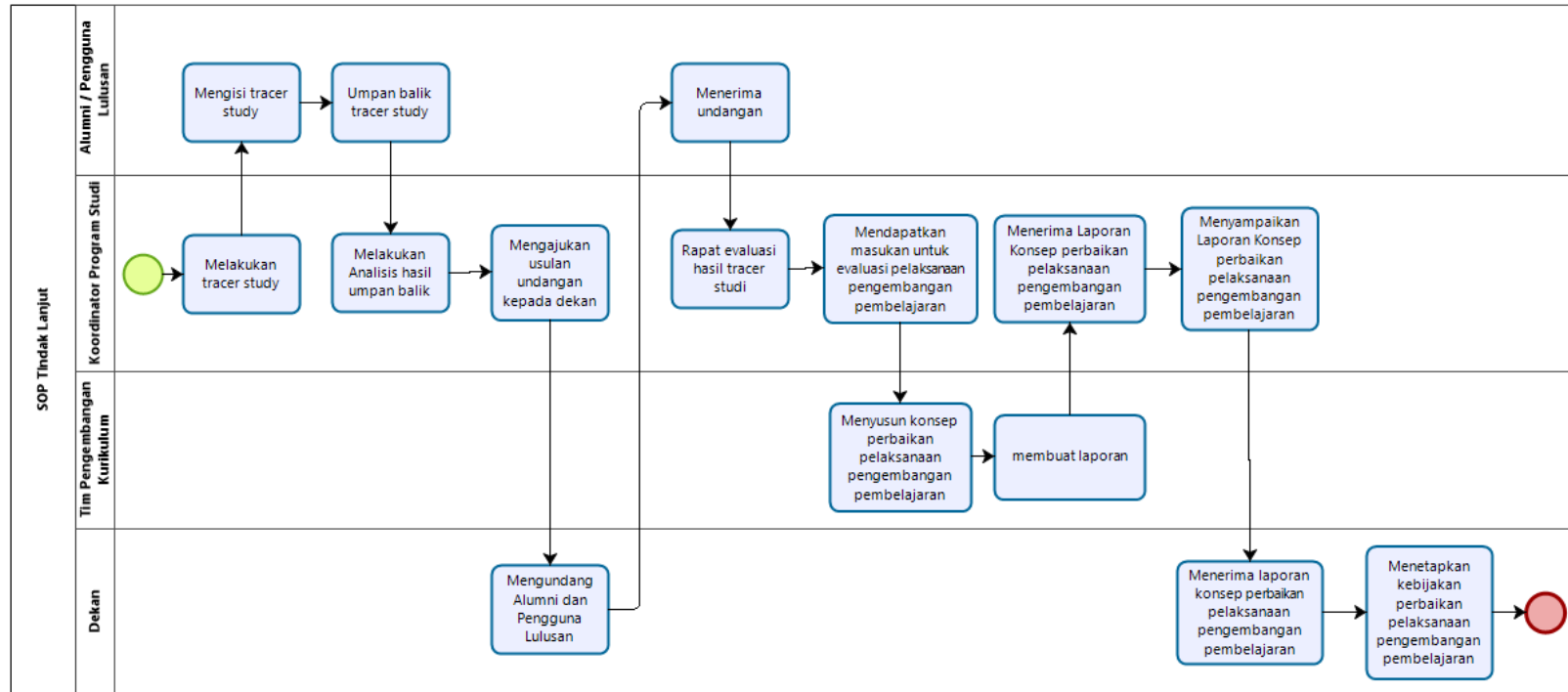



## 205 SOP Tugas Akhir

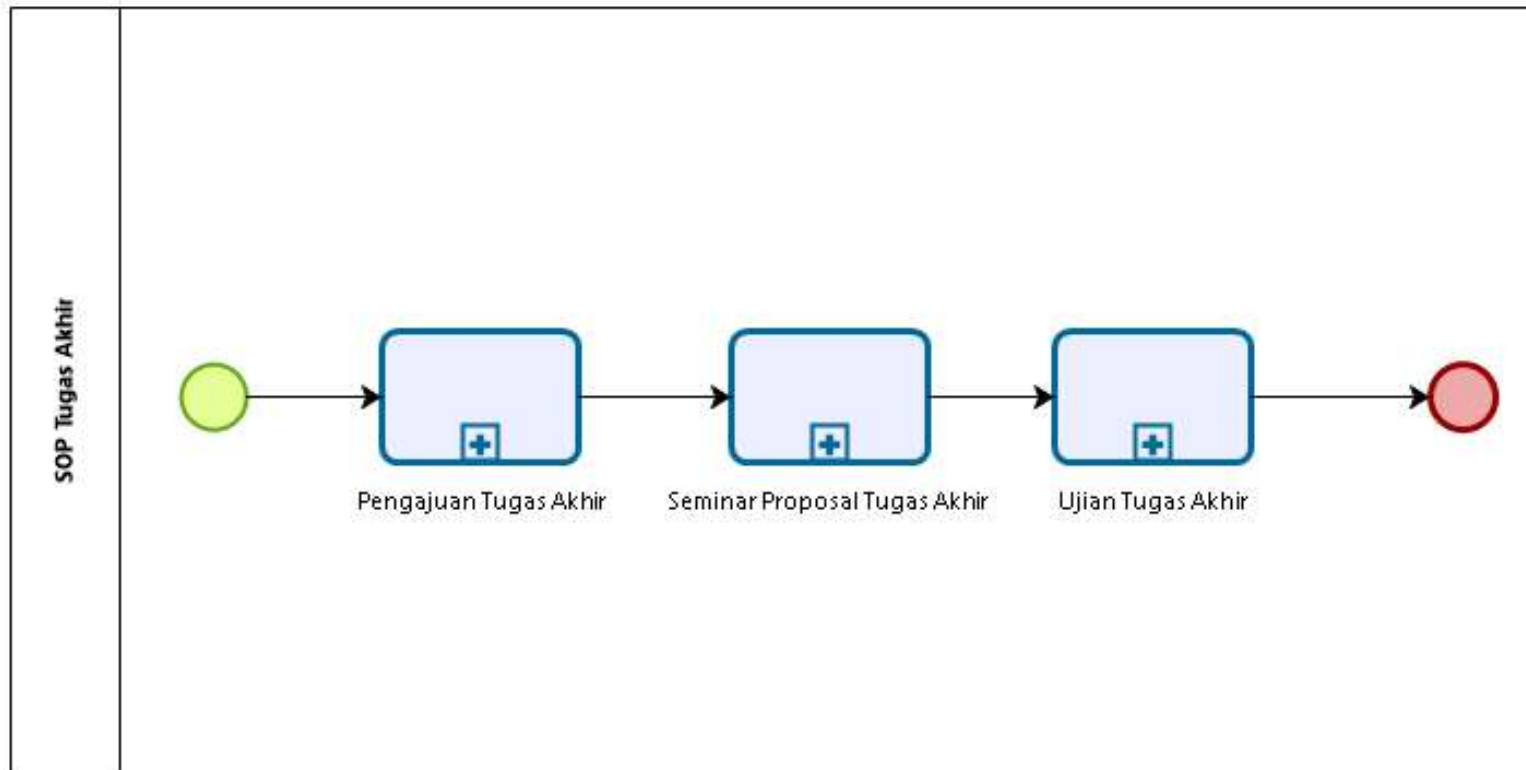





## 206 SOP Ujian Tugas Akhir

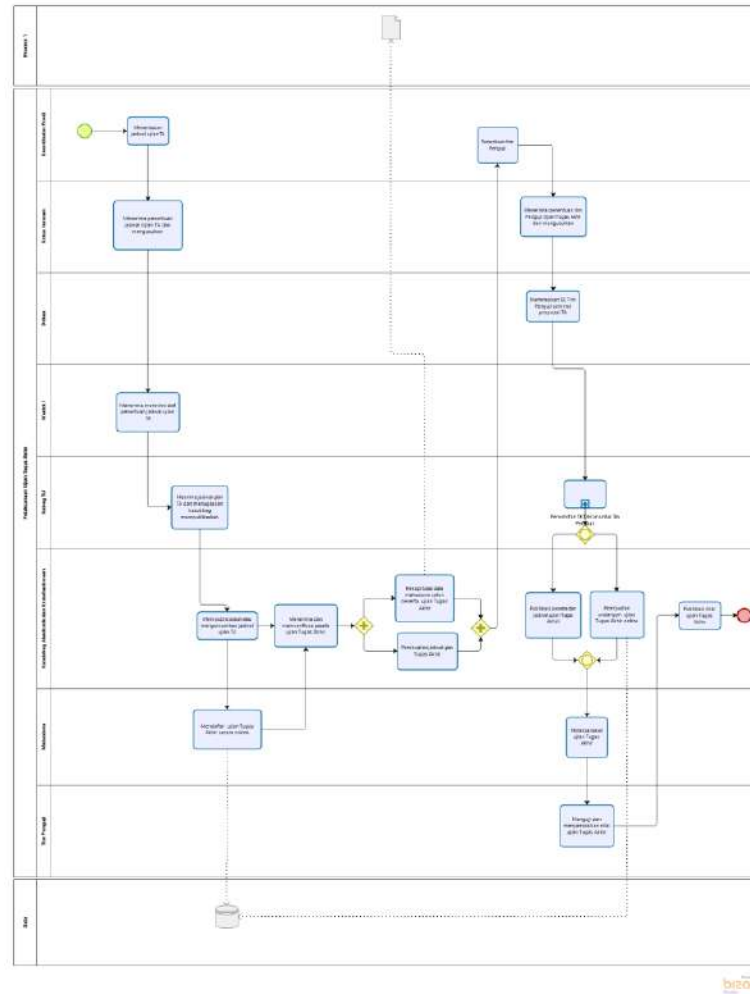



## 207 SOP Unggah Mandiri

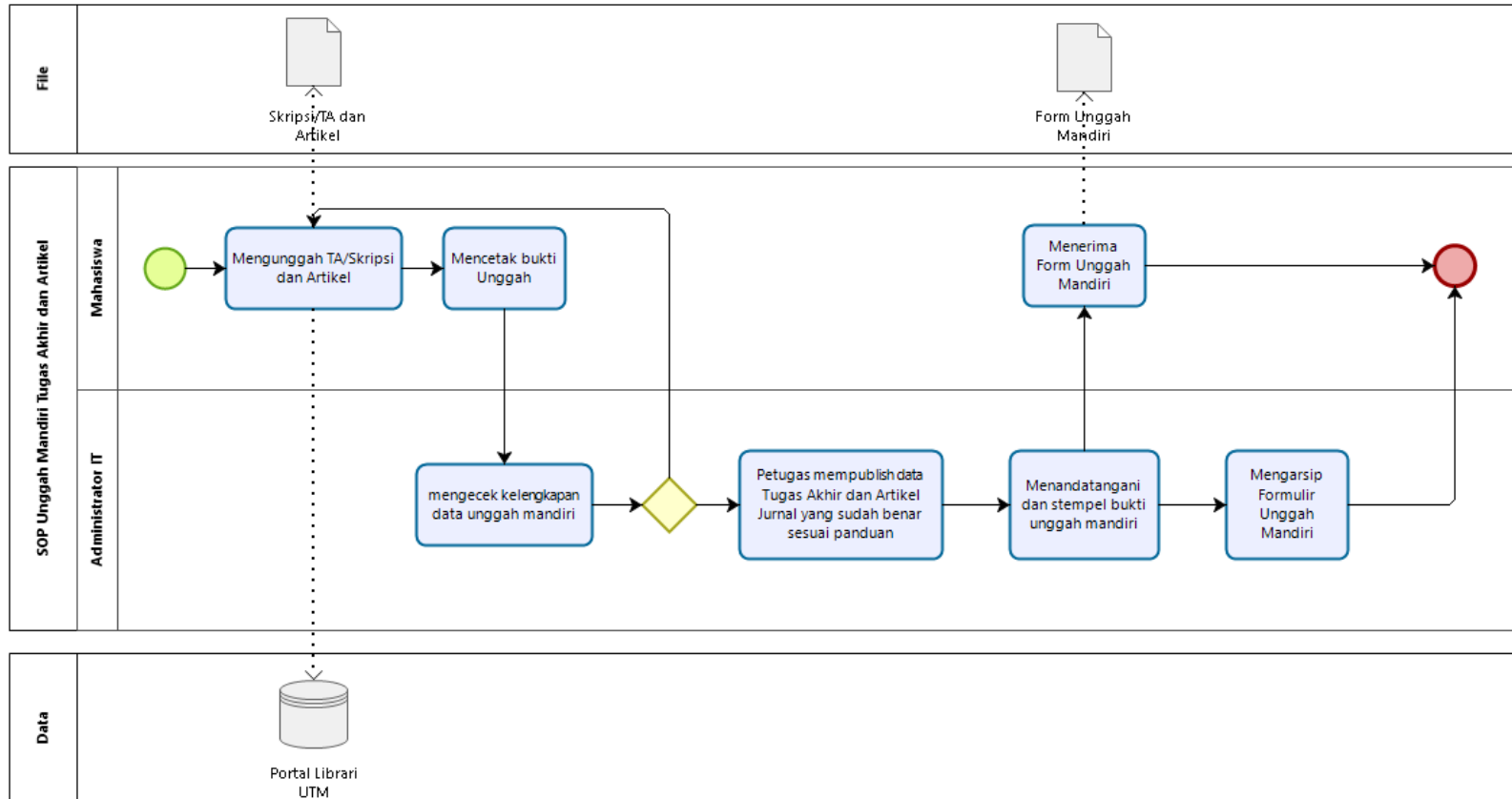



## 208 SOP Upacara Peringatan Hari Besar Nasional

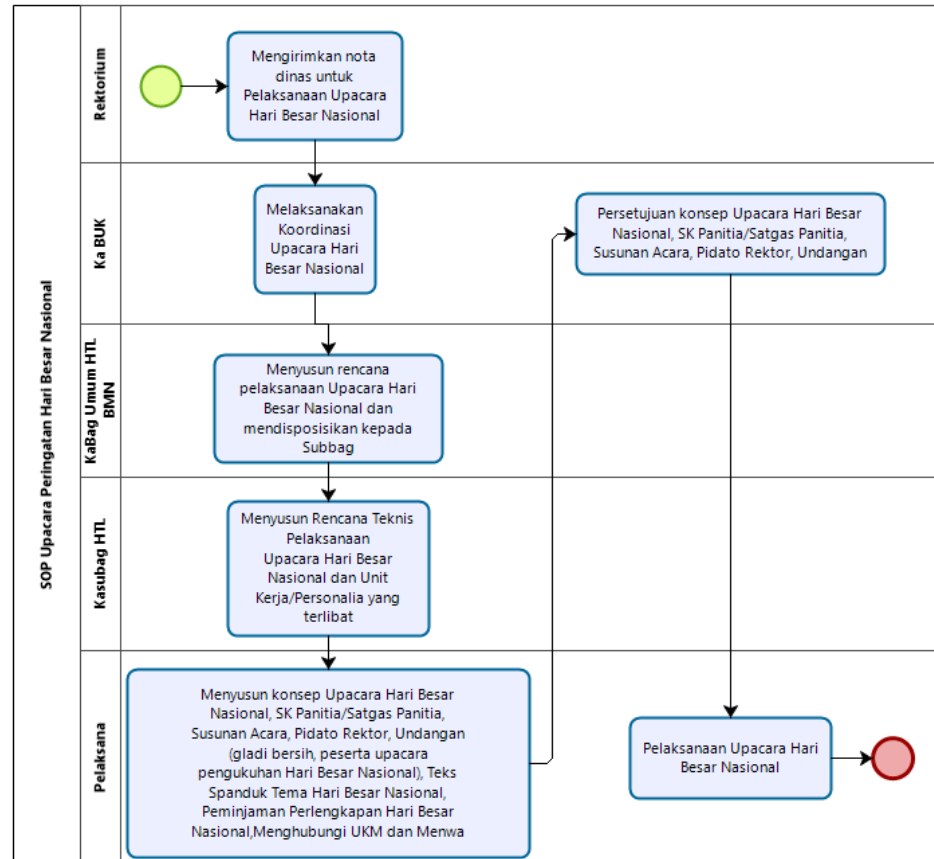



## 209 SOP Verifikasi Raport Jalur SNMPTN

